



**Compact Vehicle Tracking Device**

**Model: GV65**

# **User Manual**

*International Telematics Solutions Innovator*

[www.queclink.com](http://www.queclink.com)

Document Title	GV65 User Manual
Version	R1.00
Date	2015-06-09
Status	Release
Document Control ID	TRACGV65UM001

### **General Notes**

Queclink offers this information as a service to its customers, to support application and engineering efforts that use the products designed by Queclink. The information provided is based upon requirements specifically provided to Queclink by the customers. Queclink has not undertaken any independent search for additional relevant information, including any information that may be in the customer's possession. Furthermore, system validation of this product designed by Queclink within a larger electronic system remains the responsibility of the customer or the customer's system integrator. All specifications supplied herein are subject to change.

### **Copyright**

This document contains proprietary technical information which is the property of Queclink. Copying of this document and giving it to others and the using or communication of the contents thereof, are forbidden without express authority. Offenders are liable to the payment of damages. All rights reserved in the event of grant of a patent or the registration of a utility model or design. All specifications supplied herein are subject to change without notice at any time.

***Copyright © Queclink Wireless Solutions Co., Ltd. 2015***

## Contents

Contents .....	3
1 Revision History .....	6
2 Introduction .....	7
2.1. Reference .....	7
2.2. Terms and Abbreviations .....	7
3 Product Overview .....	8
3.1. Check Parts List .....	8
3.2. Parts List .....	9
3.3. Interface Definition .....	9
3.4. GV65 User Cable Colour .....	10
4 Get Started .....	11
4.1. Open the Case .....	11
4.2. Close the Case .....	11
4.3. Install a SIM Card .....	12
4.4. Power Connection .....	12
4.5. Ignition Detection.....	13
4.6. Digital Inputs .....	14
4.7. Analog Inputs .....	14
4.8. Digital Outputs .....	15
4.9. Device Status LED .....	16
4.10. 1-wire Device Connection .....	18
5 FCC Warning .....	20
5.1. FCC Radiation Exposure Statement .....	20

## Table Index

TABLE 1.	GV65 PROTOCOL REFERENCE .....	7
TABLE 2.	TERMS AND ABBREVIATIONS .....	7
TABLE 3.	PARTS LIST .....	9
TABLE 4.	DESCRIPTION OF 10 PIN CONNECTIONS.....	10
TABLE 5.	GV65 USER CABLE COLOUR DEFINITION .....	10
TABLE 6.	ELECTRICAL CHARACTERISTICS OF IGNITION DETECTION .....	13
TABLE 7.	ELECTRICAL CHARACTERISTICS OF THE DIGITAL INPUTS .....	14
TABLE 8.	ELECTRICAL CHARACTERISTICS OF DIGITAL OUTPUTS .....	15
TABLE 9.	DEFINITION OF DEVICE STATUS AND LED .....	18

## Figure Index

FIGURE 1.	THE 10 PIN CONNECTOR ON THE GV65.....	9
FIGURE 2.	OPEN THE CASE .....	11
FIGURE 3.	CLOSE THE CASE .....	11
FIGURE 4.	SIM CARD INSTALLATION.....	12
FIGURE 5.	TYPICAL POWER CONNECTION .....	13
FIGURE 6.	TYPICAL IGNITION DETECTION .....	13
FIGURE 7.	TYPICAL DIGITAL INPUT CONNECTION .....	14
FIGURE 8.	TYPICAL DIGITAL INPUT CONNECTION .....	15
FIGURE 9.	DIGITAL OUTPUT INTERNAL DRIVE CIRCUIT .....	15
FIGURE 10.	TYPICAL CONNECTION WITH RELAY .....	16
FIGURE 11.	TYPICAL CONNECTION WITH LED .....	16
FIGURE 12.	GV65 LED ON THE CASE .....	17
FIGURE 13.	TYPICAL CONNECTION WITH 1-WIRE DEVICE .....	19
FIGURE 14.	TYPICAL CONNECTION WITH IBUTTON READER .....	19
FIGURE 15.	TYPICAL CONNECTION WITH TEMPERATURE SENSOR .....	20

## 1 Revision History

Revision	Date	Author	Description of change
R1.00	2015-06-09	Caesar Geng	Initial

## 2 Introduction

The GV65 is a Compact Vehicle Tracking Device for vehicle or asset tracking. It has superior receiving sensitivity, fast TTFF (Time to First Fix) and supports quad-band GSM frequencies 850/900/1800/1900. Its location can be monitored in real time or periodically tracked by a backend server or other specified terminals. The GV65 has multiple input/output interfaces that can be used for monitoring or controlling external devices. Based on the integrated @Track protocol, the GV65 can communicate with a backend server through the GPRS network to transfer reports of emergency, geo-fence boundary crossings, scheduled GPS position and many other useful reporting features. Users can also use GV65 to monitor the status of a vehicle and control the vehicle by its external relay output. System integrators can easily set up their tracking systems based on the full-featured @Track protocol. The device have a expansion external GPS antenna

### 2.1. Reference

**Table 1. GV65 Protocol Reference**

SN	Document name	Remark
[1]	GV65 @Track Air Interface Protocol	The air protocol interface between GV65 and backend server.

### 2.2. Terms and Abbreviations

**Table 2. Terms and Abbreviations**

Abbreviation	Description
AGND	Analog Ground
AIN	Analog Input
DIN	Digital Input
DOUT	Digital Output
GND	Ground
MIC	Microphone
RXD	Receive Data
TXD	Transmit Data
SPKN	Speaker Negative
SPKP	Speaker Positive

## **3 Product Overview**



### **3.1. Check Parts List**

Before starting, check whether all the following items have been included with your GV65. If anything is missing, please contact your supplier.



### 3.2. Parts List

**Table 3. Parts List**

Name	Picture
GV65 Locator	73mm*54mm*22.7mm
User Cable	
DATA_CABLE_M (Optional)	

### 3.3. Interface Definition

The GV65 has a 10 PIN interface connector. It contains the connections for power, I/O, etc. The sequence and definition of the 10PIN connector are shown in the following figure:



**Figure . . The 10 PIN Connector on the GV65**

**Table 4. Description of 10 PIN Connections**

Index	Description	Comment
1	VIN	External DC power input, 8-32V
2	GND	GND
3	OUT2	Open drain, 150 mA max
4	ADC_IN	Fuel ADC input
5	OUT1	Open drain, 150 mA max ,with latch circuit
6	DATA_1W	1-wire data bus
7	/IN2	Digital input, negative trigger
8	/IN1	Digital input, negative trigger
9	IGN	Ignition input, positive trigger
10	VDD_1W	1-wire device power output

### 3.4. GV65 User Cable Colour

**Table 5. GV65 User Cable Colour Definition**

Definition	Colour	PIN No.	Cable	PIN No.	Colour	Definition
GND	Black	2		1	Red	VIN
ADC_IN	Green	4		3	Yellow	OUT2
DATA_1W	White/Black	6		5	Blue	OUT1
/IN1	Orange	8		7	Orange/Black	/IN2
VDD_1W	Purple	10		9	White	IGN

## 4 Get Started

### 4.1. Open the Case



Figure 2. Open the Case

Insert the triangular-pry-opener into the gap on both sides of the case as shown above, and push the opener up until the case is unsnapped.

### 4.2. Close the Case



Figure 3. Close the Case

Place the cover on the bottom in the position as shown in the figure above. Press the front case and the back case until it snaps.

### 4.3. Install a SIM Card

Open the case and ensure the unit is not powered (unplug the 10Pin cable). Slide the holder right to open the SIM card. Insert the SIM card into the holder as shown below with the gold-colored contact area facing down. Take care to align the cut mark. Close the SIM card holder. Close the case.



**Figure 4. SIM Card Installation**

### 4.4. Power Connection

VIN (PIN1)/GND (PIN2) are the power input pins. The input voltage range for this device is from 8V to 32V. The device is designed to be installed in vehicles that operate on 12V or 24V systems without the need for external transformers.

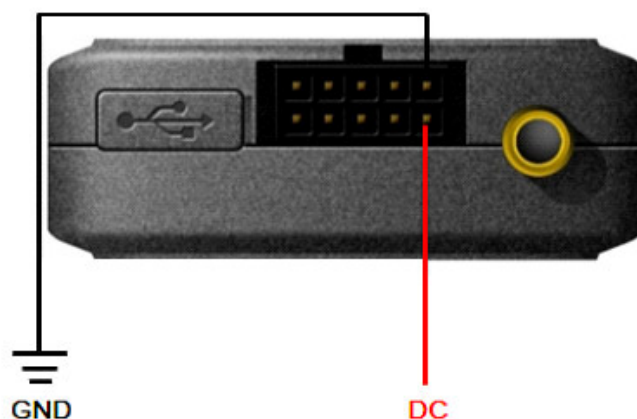

Figure 5. Typical Power Connection

### 4.5. Ignition Detection

Table 6. Electrical Characteristics of Ignition Detection

Logical status	Electrical status
Active	8.0V to 32V
Inactive	0V to 3V or open

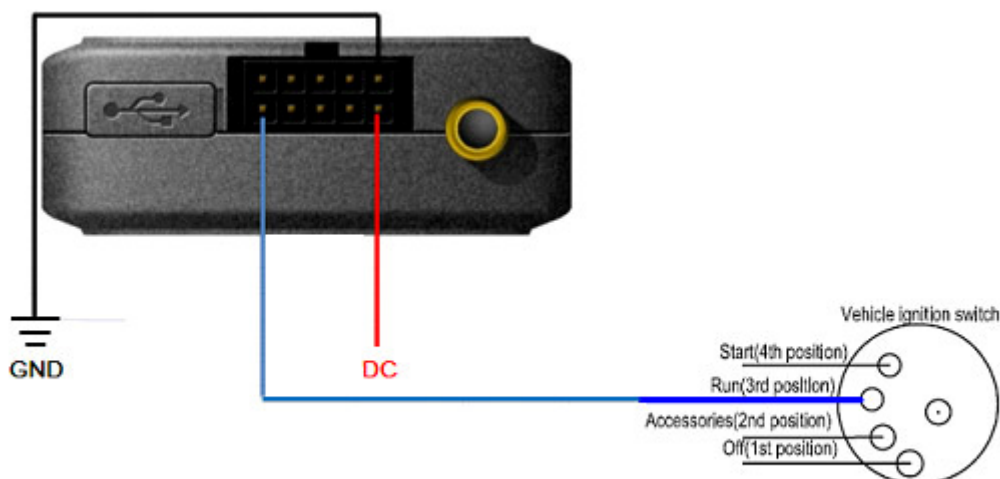

Figure 6. Typical Ignition Detection

IGN (Pin9) is used for ignition detection. It is strongly recommended to connect this pin to ignition key “RUN” position as shown above.

An alternative to connecting to the ignition switch is to find a non-permanent power source that is only available when the vehicle is running. For example, the power source for the FM radio.

IGN signal can be configured to start transmitting information to the backend server when ignition is on and enter power saving mode when ignition is off.

## 4.6. Digital Inputs

There are two general purpose digital inputs on GV65. They are all negative triggers.

**Table . . Electrical Characteristics of the Digital Inputs**

Logical status	Electrical characteristics
Active	0V to 0.8V
Inactive	Open

The following diagram shows the recommended connection of the two digital inputs.

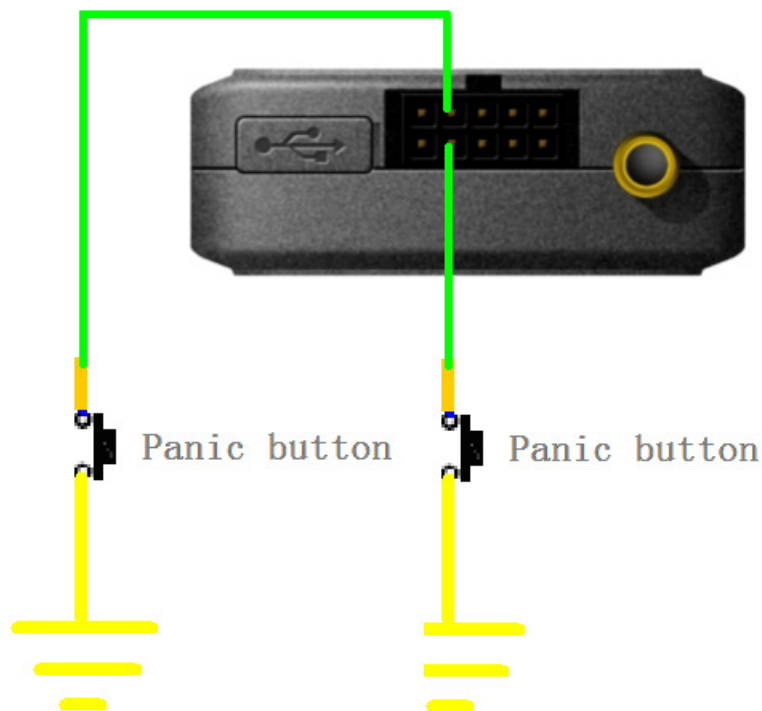

**Figure 7. Typical Digital Input Connection**

## 4.7. Analog Inputs

There is one analog input on GV65. The analog input voltage range could be selectable, including 0-12V and 0-30V, and the default range is from 0 to 30V. The following diagram shows the recommended connection.

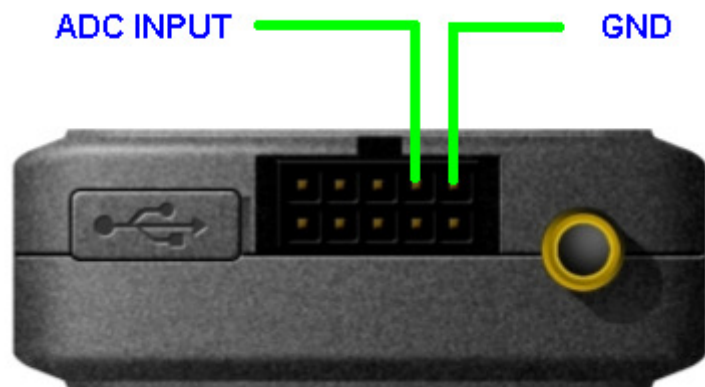

Figure 8. Typical Digital Input Connection

### 4.8. Digital Outputs

There are two digital outputs on GV65. All are of open drain type and the maximum drain current is 150 mA. Each output has the built-in over current PTC resettable fuse.

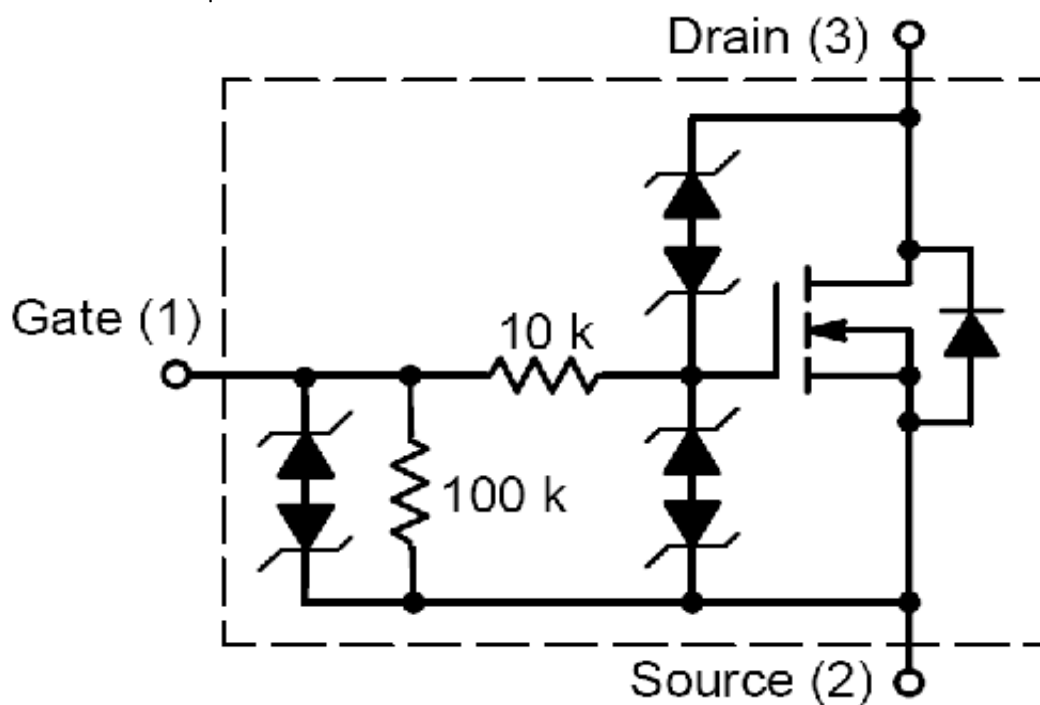

Figure 9. Digital Output Internal Drive Circuit

Table 8. Electrical Characteristics of Digital Outputs

Logical status	Electrical characteristics
Enable	<1.5V @150 mA
Disable	Open drain

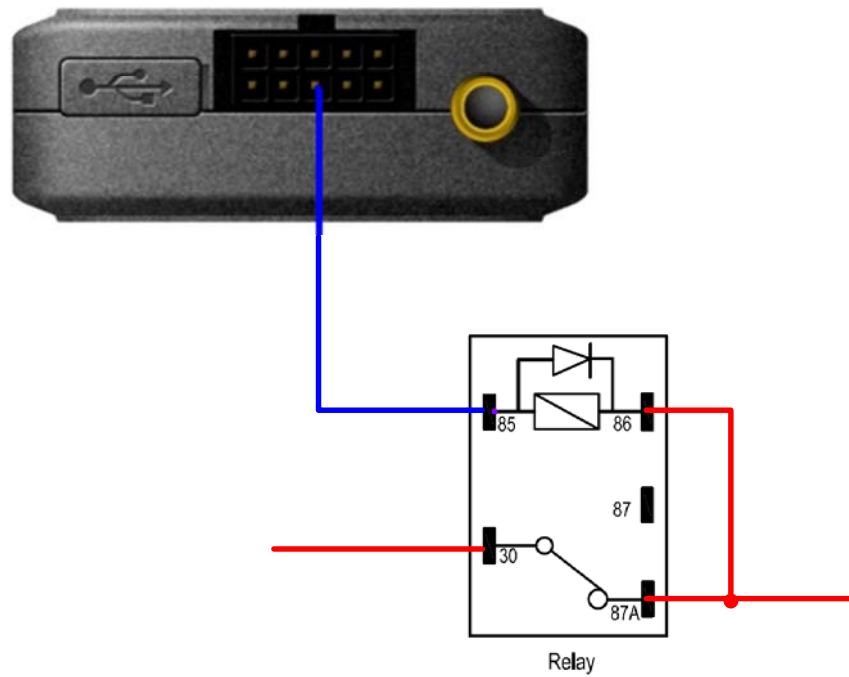

Figure 10. Typical Connection with Relay

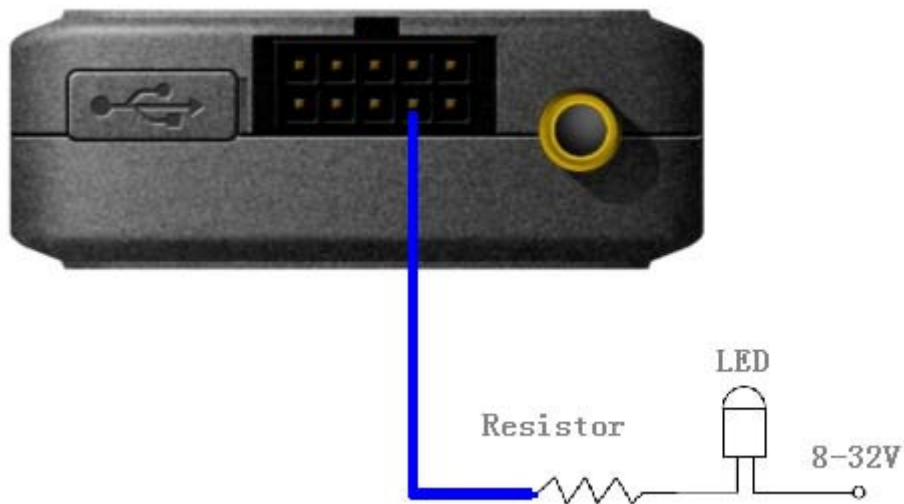

Figure 11. Typical Connection with LED

Note:

- 1 - OUT1 will latch the output state during reset.
- 2- Many modern relays come with a flyback diode pre-installed internal to the relay itself. If the relay has this diode, ensure the relay polarity is properly connected. If this diode is not internal, it should be added externally. A common diode such as a 1N4004 will work in most circumstances.

#### 4.9. Device Status LED



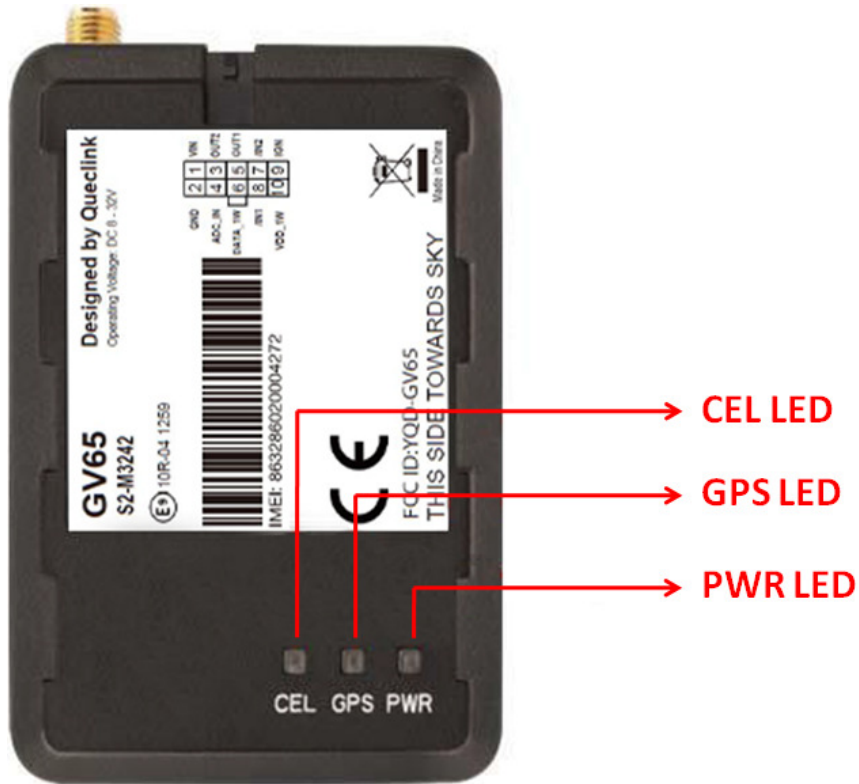

Figure 12. GV65 LED on the Case

GV65 has three status LEDs, namely, CEL, GPS and PWR.

**Table 9. Definition of Device Status and LED**

Note:

LED	Device status	LED status
GSM (note1)	Device is searching GSM network.	Fast flashing (Note 3)
	Device has registered to GSM network.	Slow flashing (Note 4)
	SIM card needs pin code to unlock.	ON
GPS (note 2)	GPS chip is powered off.	OFF
	GPS sends no data or data format error occurs.	Slow flashing
	GPS chip is searching GPS info.	Fast flashing
	GPS chip has gotten GPS info.	ON
PWR (note 2)	No external power and internal battery voltage is lower than 3.35V.	OFF
	No external power and internal battery voltage is below 3.5V.	Slow flashing
	External power in and internal battery is charging.	Fast flashing
	External power in and internal battery is fully charged.	ON

1 - GSM LED cannot be configured.

2 - GPS LED and PWR LED can be configured to turn off after a period of time by using the configuration tool.

3 - Fast flashing is about 60 ms ON/780 ms OFF.

4 - Slow flashing is about 60 ms ON/1940 ms OFF.

#### 4.10. 1-wire Device Connection

It has 1-wire bus on GV65, which supports temperature sensors and iButton. The bus includes 3 signals, namely, VDD-1W, DATA-1W and GND. VDD-1W is the power output for 1-wire device, and DATA-1W is the data signal, with which GV65 can get information from 1-wire device.

The following diagrams show the recommended connection of 1-wire device.

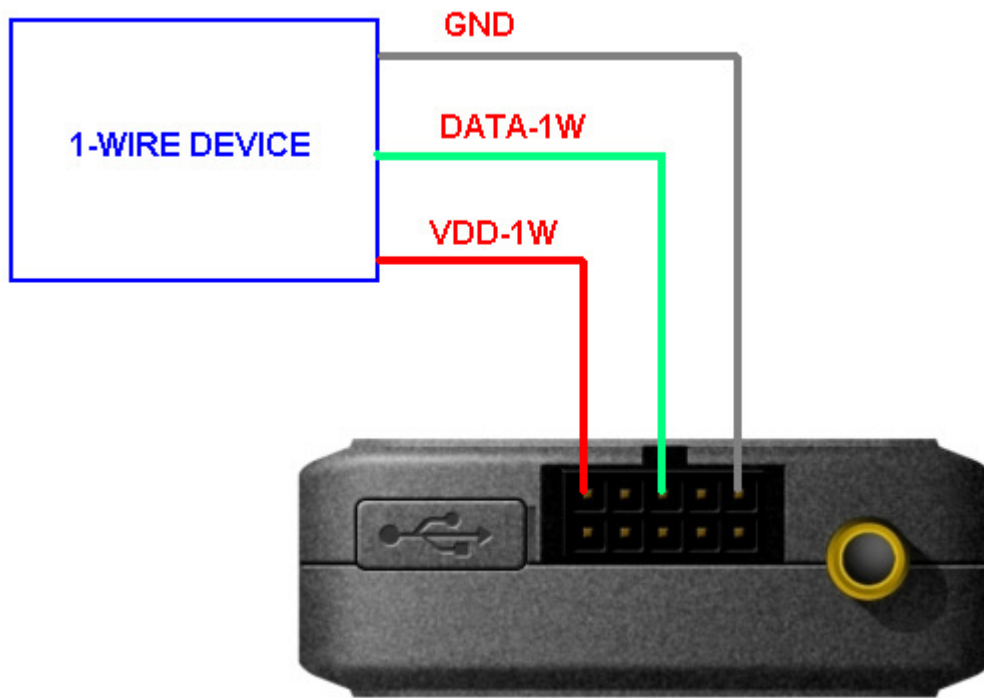

Figure 13. Typical Connection with 1-wire Device

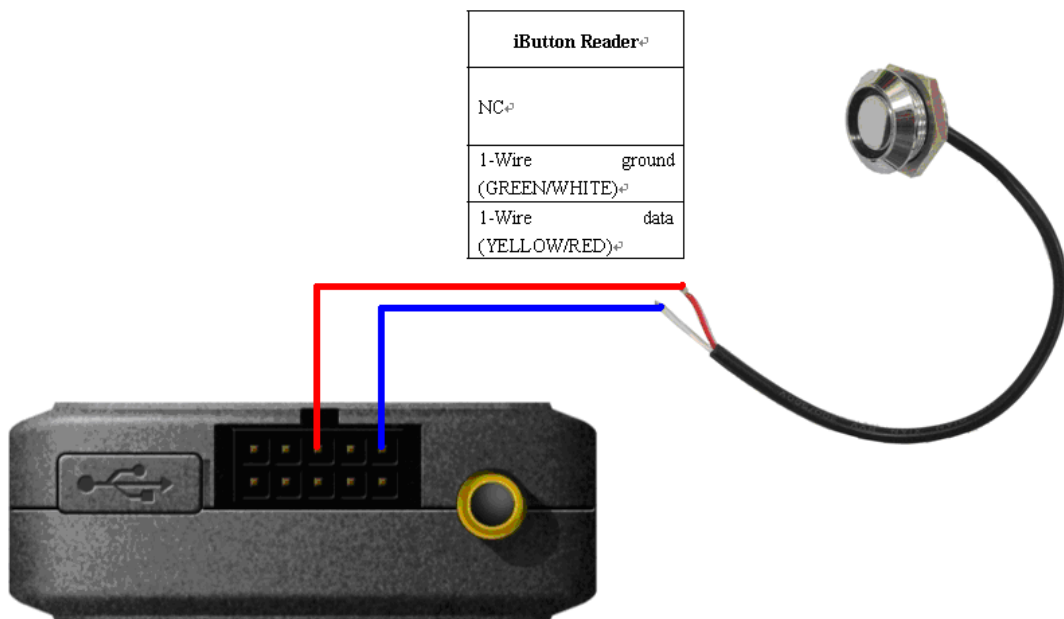
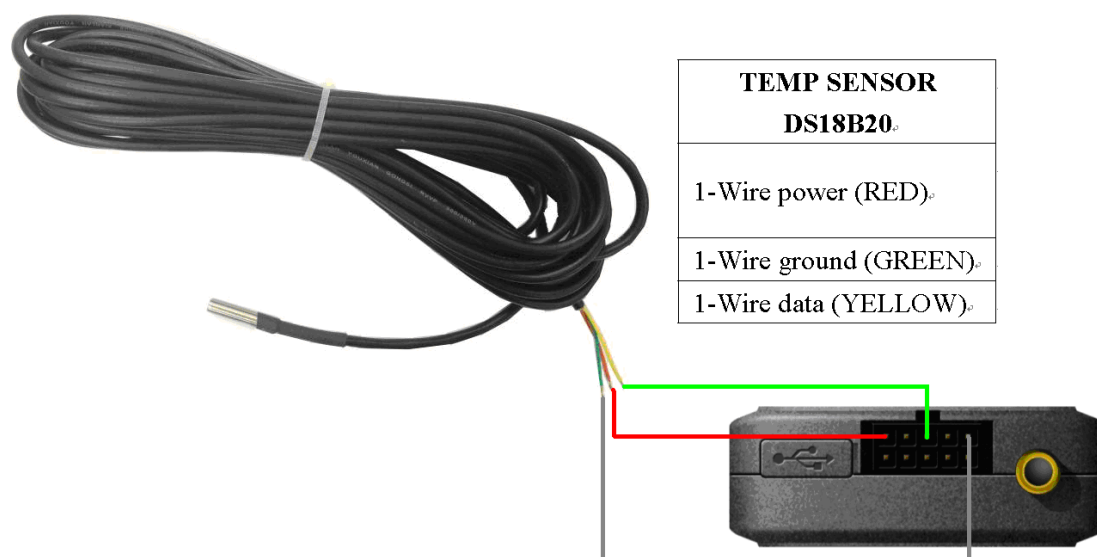

Figure 14. Typical Connection with iButton Reader



**Figure 15. Typical Connection with Temperature Sensor**

---

### **5 FCC Warning:**

Any Changes or modifications not expressly approved by the party responsible for compliance could void the user's authority to operate the equipment.

This device complies with part 15 of the FCC Rules. Operation is subject to the following two conditions: (1) This device may not cause harmful interference, and (2) this device must accept any interference received, including interference that may cause undesired operation.

#### **5.1.FCC Radiation Exposure Statement:**

This equipment complies with FCC radiation exposure limits set forth for an uncontrolled environment. This equipment should be installed and operated with minimum distance 20cm between the radiator & your body.

This transmitter must not be co-located or operating in conjunction with any other antenna or transmitter.