



FM3600 User Manual V1.2

***This version is suitable for device with universal FM36YX firmware
v.01.05.06 and later versions**

Table of contents

1	INTRODUCTION	5
1.1	ATTENTION	5
1.2	INSTRUCTIONS OF SAFETY	5
1.3	LEGAL NOTICE	6
1.4	ABOUT DOCUMENT	6
2	BASIC DESCRIPTION	7
2.1	PACKAGE CONTENTS	7
2.2	BASIC CHARACTERISTICS	7
2.3	TECHNICAL FEATURES.....	9
	ELECTRICAL CHARACTERISTICS	11
2.4	ABSOLUTE MAXIMUM RATINGS.....	12
2.5	TECHNICAL INFORMATION ABOUT INTERNAL BATTERY.....	12
3	CONNECTION, PINOUT, ACCESSORIES	13
3.1	HOW TO INSERT SIM CARD AND ATTACH BATTERY INTO FM3600 DEVICE:.....	13
3.2	INSTALLING FM3600 DRIVERS	14
3.3	NAVIGATE LED.....	16
3.4	MODEM LED.....	16
3.5	STATUS LED	16
3.6	FM3600_C2 SOCKET 2×3*	16
3.7	FM3600_C1 SOCKET 2×3***	17
3.8	USB.....	18
3.9	ACCESSORIES.....	18
4	FIRMWARE	22
4.1	UPDATING FIRMWARE USING USB CABLE	22
5	OPERATIONAL BASICS.....	23
5.1	OPERATIONAL PRINCIPALS.....	23
5.2	SLEEP MODES.....	24
5.2.1	<i>Sleep mode</i>	24
5.2.2	<i>Deep Sleep mode</i>	24
5.3	VIRTUAL ODOMETER.....	25
5.4	FEATURES.....	25
5.4.1	<i>Scenarios</i>	25
5.4.2	<i>Trip</i>	26
5.4.3	<i>Geofencing</i>	26
5.4.4	<i>iButton list</i>	26
5.5	CONFIGURATION.....	26
5.6	CONFIGURATOR.....	26
5.7	READ RECORDS.....	29
5.8	SYSTEM SETTINGS.....	30
5.9	RECORDS SETTINGS.....	32
5.10	GSM SETTINGS, GPRS PART.....	32
5.11	GSM SETTINGS, SMS PART	32
5.12	GSM SETTINGS, OPERATOR LIST	34
5.13	DATA ACQUISITION MODE SETTINGS	34
5.14	FEATURES SETTINGS.....	38
5.14.1	<i>Scenarios settings</i>	39
5.14.2	<i>Trip settings</i>	40
5.14.3	<i>Geofencing settings</i>	41
5.14.4	<i>SMS events</i>	43
5.15	I/O SETTINGS.....	49
5.15.1	<i>Monitoring</i>	52
5.15.2	<i>Event Generating</i>	52

5.15.3	Hysteresis	52
6	SMS COMMAND LIST	53
6.1	SMS COMMAND LIST.....	53
6.1.1	getstatus.....	54
6.1.2	getweektime.....	54
6.1.3	getops.....	55
6.1.4	getcfgtime	55
6.1.5	getgps.....	55
6.1.6	ggps.....	55
6.1.7	getver	55
6.1.8	getinfo	56
6.1.9	getio.....	56
6.1.10	radio #.....	56
6.1.11	setdigout ## Y1 Y2	57
6.1.12	getparam #####	57
6.1.13	setparam #####.....	57
6.1.13.	getparam 1271 X/212 X	57
6.1.14.	setparam 1271 X/212 X.....	57
6.1.15	readops #.....	57
6.1.16	flush #,#,#,#,#,#	57
6.1.17	sn #	58
6.1.18	banlist.....	58
6.1.19	crashlog	58
6.1.20	lvcagetprog.....	58
6.1.21	lvcansetprog #	58
6.1.22	lvcangetinfo.....	58
7	DEBUG MODE	58
8	PARAMETER LIST	59
8.1	PARAMETERS VALUE TYPES.....	59
8.2	SYSTEM PARAMETERS	59
8.2.1	Sleep Mode (ID=1000)	59
8.2.2	Sleep timeout (ID=200).....	60
8.2.3	Analog Input value range (ID=1001)	60
8.2.4	Stop Detection Source (ID=1002).....	60
8.2.5	Static Navigation (ID=1003)	60
8.2.6	Ignition Source (ID=1004).....	60
8.2.7	GNSS FIX Timeout for Time Synchronization via NTP (ID=1007).....	60
8.2.8	Saving/Sending without time synchronization (ID=201)	61
8.2.9	GNSS System (ID=202).....	61
8.3	RECORDS PARAMETERS	61
8.3.1	Sorting (ID=1010)	61
8.3.2	Active Data Link Timeout (ID=1011).....	61
8.3.3	Server Response Timeout (ID=1012).....	61
8.4	GSM PARAMETERS	62
8.4.1	GPRS content activation (ID=1240)	62
8.4.2	APN Name (ID=1242).....	62
8.4.3	APN username (ID=1243)	62
8.4.4	APN Password (ID=1244).....	62
8.4.5	Domain (ID=1245)	63
8.4.6	Target Server Port (ID=1246).....	63
8.4.7	Protocol (ID=1247).....	63
8.4.8	Use 2G only (ID=1248).....	63
8.4.9	SMS Login (ID=1252)	63
8.4.10	SMS Password (ID=1253).....	63
8.4.11	SMS Time Zone (ID=1254).....	63
8.4.12	SMS data sending settings (ID=1250).....	64

8.4.13	SMS Data send week time schedule (ID=1273)	64
8.4.14	Authorized phone numbers (ID=1260-1270)	64
8.4.15	SMS Event PreDefined Numbers (ID=150-159)	64
8.4.16	Operator List (ID=1271 X)	64
8.5	DATA ACQUISITION MODES PARAMETERS	65
8.5.1	Home Network GSM operator code "Vehicle on STOP" parameters	65
8.5.2	Home Network GSM operator code "Vehicle MOVING" parameters	66
8.5.3	Roaming Network GSM operator code "Vehicle on STOP" parameters	67
8.5.4	Roaming Network GSM operator code "Vehicle MOVING" parameters	68
8.5.5	Unknown Network GSM operator code "Vehicle on STOP" parameters	69
8.5.6	Unknown Network GSM operator code "Vehicle MOVING" parameters	70
8.6	FEATURES PARAMETERS	72
8.6.1	Green Driving scenario (ID=1600)	72
8.6.2	Max Acceleration Force (ID=1602)	72
8.6.3	Max Braking Force (ID=1603)	72
8.6.4	Max Cornering Force (ID=1604)	72
8.6.5	Max allowed Speed (ID=1605)	72
8.6.6	OverSpeeding scenario (ID=1601)	72
8.6.7	Jamming detection scenario (ID=1606)	73
8.6.8	Immobilizer scenario (ID=1607)	73
8.6.9	iButton list checking scenario (ID=1608)	73
8.6.10	Trip (ID=1280)	73
8.6.11	Start Speed (ID=1281)	73
8.6.12	Ignition Off Timeout (ID=1282)	73
8.6.13	Trip Continuous distance counting (ID=1283)	74
8.6.14	Geofencing	74
8.6.15	AutoGeofencing	76
8.6.16	iButton List (ID=7000-7499)	76
8.7	I/O PARAMETERS	77
8.7.1	I/O#1 Priority (ID=2000)	77
8.7.2	I/O#1 event generation type (ID=2001)	77
8.7.3	I/O#1 Low level (ID=2002)	77
8.7.4	I/O#1 High level (ID=2003)	77
8.7.5	I/O#1 averaging length (ID=2004)	77
8.8	SMS EVENT CONFIGURATION	80
8.8.1	I/O#1 element SMS event configuration (ID=5100)	80
9	FM3600 WITH LIGHT VEHICLES CAN ADAPTER LV-CAN200	82
9.1	PURPOSE OF LIGHT VEHICLES CAN ADAPTER LV-CAN200	82
9.2	LV-CAN200 PROGRAM NUMBER SELECTION	83
9.2.1	LV-CAN200 program number configuration via SMS command	83
9.2.2	Selecting LV-CAN200 program number manually	83
9.2.3	Program number logic change	84
9.3	CONNECTING FM3600 WITH LIGHT VEHICLES CAN ADAPTER	85
9.4	FM11 CONFIGURATION	86
9.5	PARAMETERS ID	88
9.6	SMS CONFIGURATION	88
9.7	CAN PROGRAM NUMBER REQUEST BY SMS	89
9.8	GET LV-CAN INFO BY SMS	89
9.9	REFERENCES	90
9.10	CONNECTING WIRES	91
9.11	CONNECTING POWER SOURCE	91
9.12	CONNECTING IGNITION WIRE	91
9.13	CONNECTING GROUND WIRE	91
9.14	CONNECTING ANTENNAS	92
9.15	MODULE INSTALLATION	92
10	CHANGE LOG	93

1 INTRODUCTION

1.1 Attention



Do not disassemble the device. If the device is damaged, the power supply cables are not isolated or the isolation is damaged, before unplugging the power supply, do not touch the device.



All wireless data transferring devices produce interference that may affect other devices which are placed nearby.



The device must be connected only by qualified personnel.



The device must be firmly fastened in the predefined location.



The programming must be performed using a second class PC (with autonomic power supply).



The device is susceptible to water and humidity.



Any installation and/or handling during a lightning storm are prohibited.



FM3600 has USB interface;
Please use cables provided with FM3600 device.
Teltonika is not responsible for any harm caused by using wrong cables for PC <-> FM3600 connection.

1.2 Instructions of safety

This chapter contains information on how to operate FM3600 safely. By following these requirements and recommendations, you will avoid dangerous situations. You must read these instructions carefully and follow them strictly before operating the device!

The device uses a 10 V...30 V DC power supply. The nominal voltage is 12 V DC. The allowed range of voltage is 10 V...30 V DC.

To avoid mechanical damage, it is advised to transport the FM3600 device in an impact-proof package. Before usage, the device should be placed so that its LED indicators are visible, which show the status of operation the device is in.

When connecting the connection (2x3) cables to the vehicle, the appropriate jumpers of the power supply of the vehicle should be disconnected.

Before dismounting the device from the vehicle, the 2x3 connection must be disconnected.

The device is designed to be mounted in a zone of limited access, which is inaccessible for the operator. All related devices must meet the requirements of standard EN 60950-1.

The device FM3600 is not designed as a navigational device for boats.

1.3 Legal Notice

Copyright © 2013 Teltonika. All rights reserved. Reproduction, transfer, distribution or storage of part or all of the contents in this document in any form without the prior written permission of Teltonika is prohibited.

Other products and company names mentioned here may be trademarks or trade names of their respective owners.

The manufacturer reserves the right to make changes and/or improvements at any time in design, functionality, parameters and electrical characteristics without any prior notice and without incurring obligations.

1.4 About document

This document contains information about the architecture, possibilities, mechanical characteristics, and configuration of the FM3600 device.

Acronyms and terms used in document

PC – Personal Computer.

GPRS – General Packet Radio Service

GNSS – Global Positioning System

GSM – Global System for Mobile Communications

SMS – Short Message Service

AC/DC – Alternating Current/Direct Current

I/O – Input/Output

Record – AVL data stored in FM3600 memory. AVL data contains GNSS and I/O information

AVL packet – data packet that has been sent to server during data transmission. AVL packet contains from 1 to 50 records.



NOTE: FM3600 device is designed to have 2 different hardware configurations so that clients could use the one which fulfills their needs best.

In this document the functionality of every hardware configuration is described using denotations:



FM3600_C1 – device having PINOUT configuration 1 (refer. Chapter 3.7);

FM3600_C2 – device having PINOUT configuration 2 (refer. Chapter 3.6; FM3600 – is used to describe common functionality;

2 BASIC DESCRIPTION

FM3600 is a terminal with GPS/GLONASS and GSM/3G connectivity with backup battery, which is able to collect device coordinates and other useful data and transfer them via the GSM/3G network. This device is perfectly suitable for applications where location acquirement of remote objects is needed. It is important to mention that FM3600 has additional inputs and outputs, which let you control and monitor other devices on remote objects. FM3600 also has a USB port for device status log output and configuration.

2.1 Package contents¹

The FM3600 device is supplied to the customer in a cardboard box containing all the equipment that is necessary for operation. The package contains:

FM3600 device;

Input and output power supply cable with a 2x3 connection pins;

GNSS antenna;

GSM/3G antenna;

USB cable;

170mAh Li-ion rechargeable 3,7V battery

A card, which contains URL to download FM3600 device drivers and Configurator software.

2.2 Basic characteristics

GSM / GPRS / 3G features:

- UMTS/HSPA+, GSM/GPRS/EDGE module
- UMTS/HSPA+ bands:
 - 800/850/900/1900/2100MHz UMTS
 - 850/900/1800/1900MHz GSM
- HSUPA rate up to 5.76 Mbps, HSDPA rates up to 14.4 Mbps
- UMTS Uplink/Downlink up to 384 kbps
- EDGE Uplink/Downlink up to 236.8 kbps
- GPRS and EDGE class 12;
- SMS (text, data).

FM3600 Interface features:

- Power supply: 10 ÷ 30V;
- 1 Universal Digital/Analog input;
- 2 open collector Digital output*;
- 1 Wire interface*:
 - Temperature sensor
 - iButton
- 170mAh Li-ion rechargeable 3,7V battery;
- 3 Status LEDs:
 - Navigate
 - Status

¹ Package content depends on Order Code, and can be customized by customer needs.

* Depends on FM3600 PINOUT configuration (chapters 3.6, 3.7)

- Modem
- Internal USB port;
- External GSM antenna (SMA connector) for higher sensitivity;
- External GNSS antenna (MCX connector) for higher sensitivity;

Hardware features:

- Cortex®-M3 processor;
- 1 MB internal Flash memory;
- Built-in accelerometer sensor.

GNSS features:

- G33 Multi-GNSS engine for GNSS, GLONASS, Galileo and QZSS;
- 32channel GPS/GLONASS receiver;
- Protocol NMEA-0183: GGA, GGL, GSA, GSV, RMC, VTG;
- -162 dBm Tracking Sensitivity

Special features:

- Any element event triggers (external sensor, input, speed, temperature, etc.);
- Highly configurable data acquisition and sending;
- Multiple Geo-fence areas;
- Sleep mode;
- Deep sleep mode;
- Configurable scenarios available;
- Real-time process monitoring;
- Authorized number list for remote access;
- Firmware update over GPRS or USB port;
- Configuration update over GPRS, SMS or USB port;
- TCP/IP or UDP/IP protocol support;
- Up to 3584 records storing;
- Radio frequency jamming detection.
- Records exporting using USB;
- Offline working mode;

Overvoltage protection

Description	Voltage	Duration
Normal operation	10-30V	Unlimited
Protection turns on, device turns off.	34V	Unlimited
Maximum voltage	<70V	Unlimited
Maximum voltage impulse	90V	5 mili seconds

2.3 Technical features

Table 1 FM3600 specifications

Part name	Physical specification
Modem LED	LED
System LED	LED
Navigation LED	LED
GNSS	GNSS antenna connector MCX
GSM/3G	GSM/3G antenna connector SMA female outer shell, female inner pin
Socket 2x3	Tyco Micro MATE-N-LOK™ 4-794628-0 or similar
USB	Mini USB socket

Technical details
Power supply 10...30 V DC 2W Max
Energy consumption:
GPRS: --- 150 mA r.m.s Max., Nominal: --- average 65 mA r.m.s, GNSS Sleep ² : --- average 23 mA
Deep Sleep: --- average less than 4 mA ³
Operation temperature: -25°C ... +55°C
Storage temperature: -40°C ... +70°C
Storage relative humidity 5 ... 95 % (no condensation)

² When in Sleep mode, FM unit turns OFF GNSS module.

³ When in Deep Sleep mode no data storing and sending is activated.

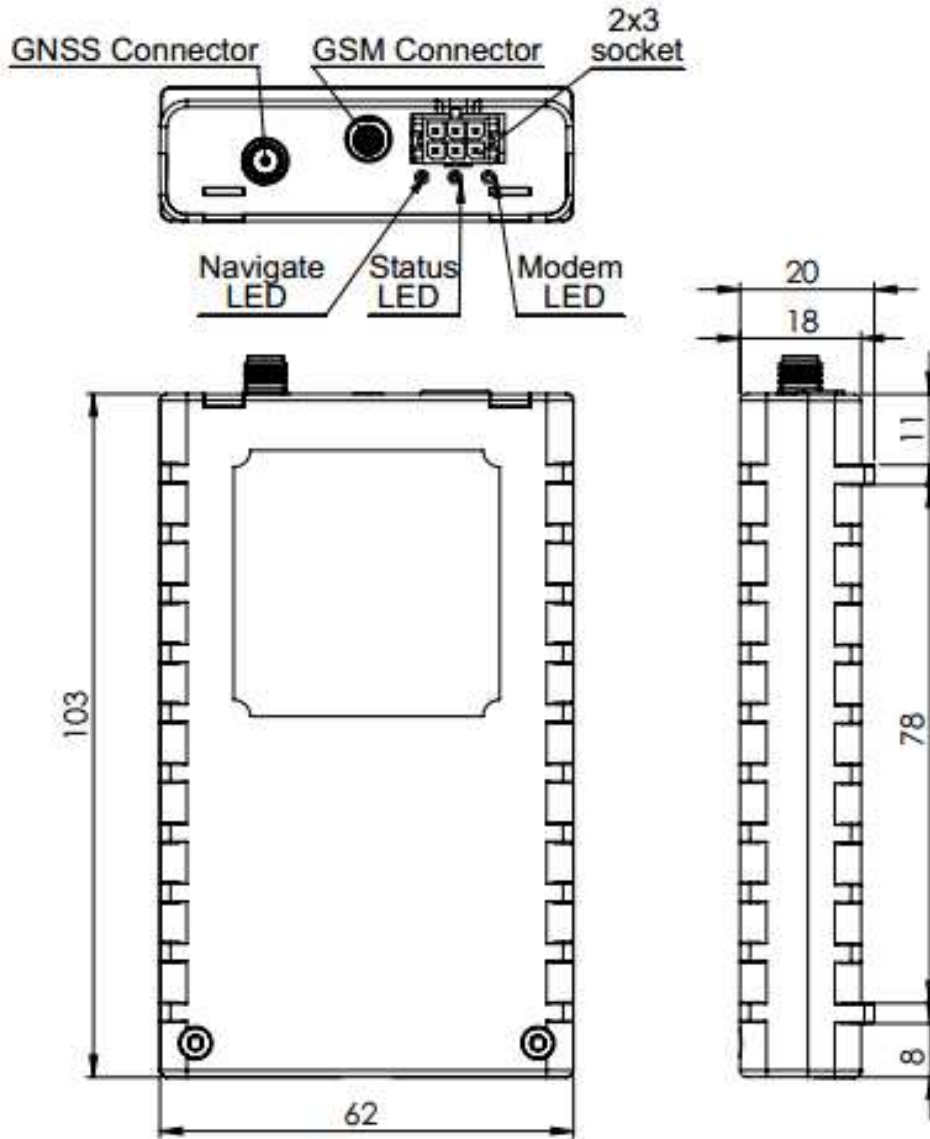

Figure 1 FM3600 view & dimensions (tolerance $\pm 2\text{mm}$)

Electrical characteristics

CHARACTERISTIC DESCRIPTION	VALUE			
	Min.	Typ.	Max.	Unit
Supply Voltage:				
Supply Voltage (Recommended Operating Conditions)	10		30	V
Digital Output (Open Drain grade):				
Drain current (Digital Output OFF)			120	uA
Drain current (Digital Output ON, Recommended Operating Conditions)			300	mA
Static Drain-Source resistance (Digital Output ON)			300	mOhm
Power supply current				
Deep sleep average on 12V	-	1,33	15	mA
Deep sleep average on 24V	-	0,51	10	mA
Sleep average on 12V	-	23	-	mA
Sleep average on 24V	-	8,9	-	mA
U _{cc} =12V, all modules fully working	-	-	700	mA
U _{cc} =24V, all modules fully working	-	-	330	mA
Digital Input:				
Input resistance (DIN1, DIN2)	15			kOhm
Input Voltage (Recommended Operating Conditions)	0		Supply voltage	V
Input Voltage threshold (DIN1)		7,5		V
Input Voltage threshold (DIN2)		2,5		V
Analog Input:				
Input Voltage (Recommended Operating Conditions), Range1	0		10	V
Input resistance, Range1		120		kOhm
Input Voltage (Recommended Operating Conditions) Range2	0		30	V
Input resistance, Range2		146,7		kOhm
Output Supply Voltage 1-Wire:				
Supply Voltage	3,3		3,6	V
Output inner resistance		7		Ohm
Output current (U _{out} > 3.0V)		30		mA

Short circuit current ($U_{out} = 0$)		130		mA
---	--	-----	--	----

2.4 Absolute Maximum Ratings

CHARACTERISTIC DESCRIPTION	VALUE	Min.	Typ.	Max.	Unit
	Supply Voltage (Absolute Maximum Ratings)		-32		32
Drain-Source clamp threshold voltage (Absolute Maximum Ratings), ($I_{drain} = 2mA$)				36	V
Digital Input Voltage (Absolute Maximum Ratings)		-32		32	V
Analog Input Voltage (Absolute Maximum Ratings)		-32		32	V

2.5 Technical Information about internal battery

FM36x0 internal battery is used for detecting external voltage disconnection.

Device	Internal back-up battery	Battery voltage V	Nominal capacity (mAh)	Power (Wh)
FM3600_C1	170 mAh Polymer Li-ion Rechargeable Battery	3.75~3.90	≥170	0.64 - 0.66
FM3600_C2	170 mAh Polymer Li-ion Rechargeable Battery	3.75~3.90	≥170	0.64 - 0.66

3 CONNECTION, PINOUT, ACCESSORIES

3.1 How to insert SIM card and attach battery into FM3600 device:

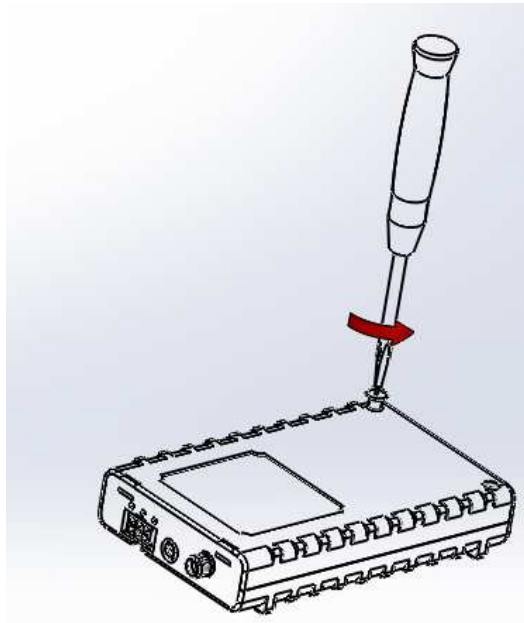

①

Gently open FM3600 case using screwdriver

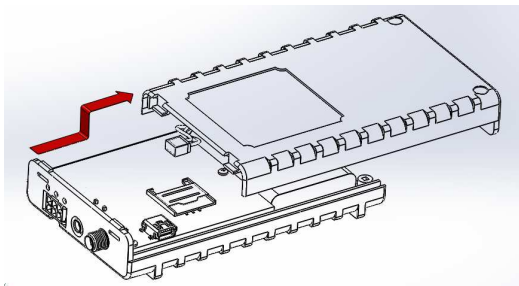

②

Remove FM3600 case

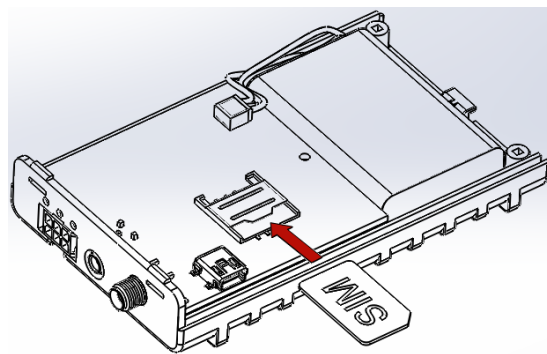

③

Insert SIM card as shown

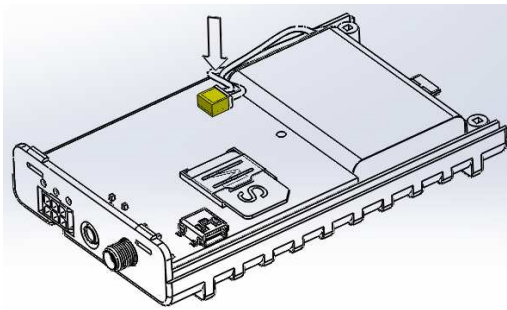

④

Attach battery

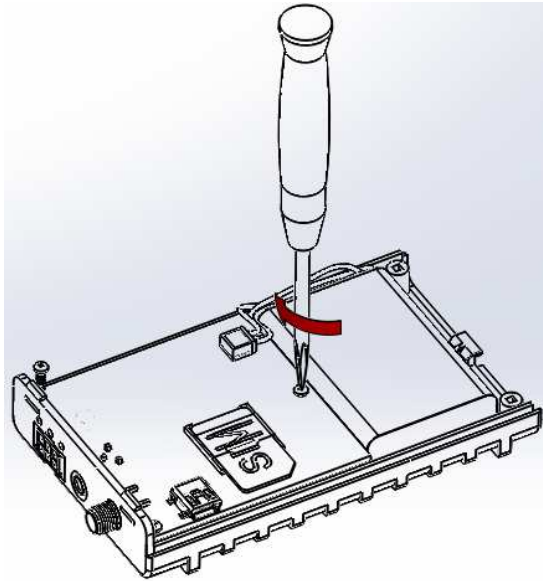

⑤

With screwdriver attach cover

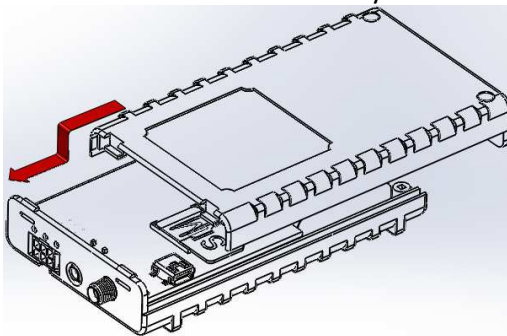

⑥

Attach top housing cover

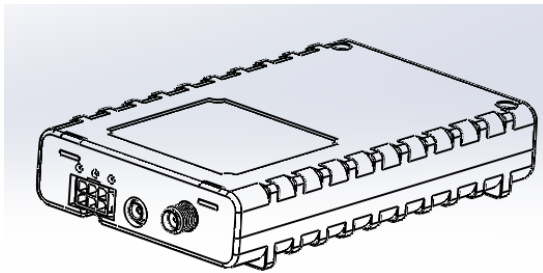

⑦

Device is ready

3.2 Installing FM3600 drivers

Software requirements:

- Operating system 32-bit and 64-bit: Windows XP with SP3 or later, Windows Vista, Windows 7.
- MS .NET Framework V3.5 or later (<http://www.microsoft.com> or <http://avl1.teltonika.lt/downloads/tavl/Framework/dotnetfx35setupSP1.zip>).

Drivers:

Please download Virtual COM Port drivers from Teltonika website:
http://avl1.teltonika.lt/downloads/FM33/vcpdriver_v1.3.1_setup.zip

Installing drivers:

Extract and run VCPDriver_V1.3.1_Setup.exe. This driver is used to detect FM3600 device connected to the computer. Click 'Next' in driver installation window (figures below):

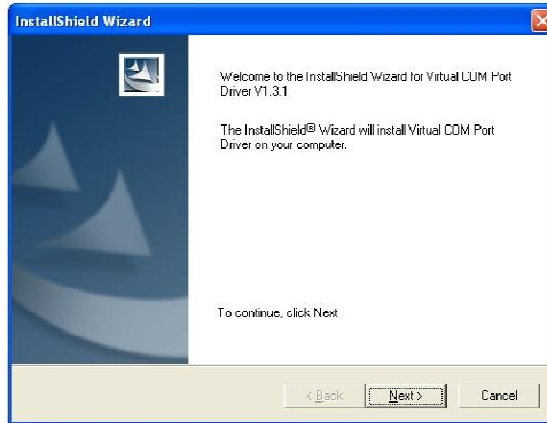

Figure 2 Driver installation window

This will launch device driver installation wizard. In the following window click 'Next' button again:



Figure 3 Driver installation window

Setup will continue installing drivers and will display a window about successful process at the end. Click 'Finish' to complete setup:



Figure 4 Driver installation window

You have now installed drivers for FM3600 device successfully.

3.3 Navigate LED

Behavior	Meaning
Permanently switched on	GNSS signal is not received
Blinking every second	Normal mode, GNSS is working
Off	GNSS is turned off because: <ul style="list-style-type: none"> • Sleep mode • Deep sleep mode Or <ul style="list-style-type: none"> • GNSS antenna short circuited

3.4 Modem LED

Behavior	Meaning
Blinking every second	Normal mode
Blinking every 2 seconds	Deep sleep mode
Blinking fast for a short time	Modem activity
Blinking fast constantly	Boot mode
Off	<ul style="list-style-type: none"> • Device is not working Or <ul style="list-style-type: none"> • Device firmware being flashed

3.5 Status LED

Behavior	Meaning
Permanently off	Device off
Blinking every 1 second	Net search / Not registered/ turning off
Slow blinking every 3 seconds	Registered: full service
Permanently on	A call is active

3.6 FM3600_C2 Socket 2x3*

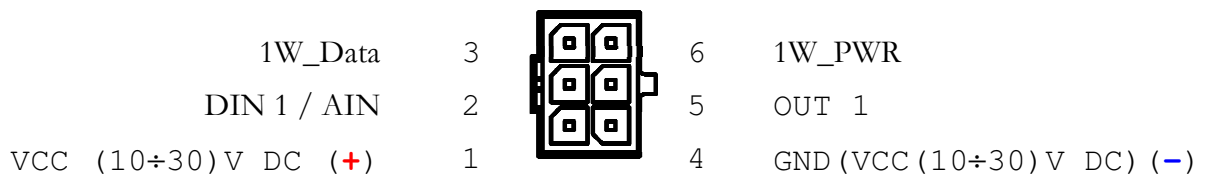

Figure 5 2x6 socket pinout

Table 2 Socket 2x3 pinout description. *- digital input status 0 ... ~2 V – FALSE; ~2,5 V... 30 V– TRUE

Pin Nr.	Pin Name	Description
1	VCC (10÷30) V DC (+)	Power supply for module. Power supply range (10÷30)V DC Energy consumption: GPRS: --- 200 mA r.m.s Max.
2	DIN 1 / AIN	Digital input, channel 1* / Analog input 0-30 V range
3	1W_Data	Data channel for Dallas 1-Wire® devices
4	GND (-)	Ground pin.
5	OUT 1	Digital output. Channel 1. Open collector output. Max. --- 150mA.
6	1W_PWR	+ 3,8 V output for 1-Wire® devices. (max 20mA)

*** The described PINOUT is used only for FM3600_C2 hardware configuration!!!**

3.7 FM3600_C1 Socket 2x3***

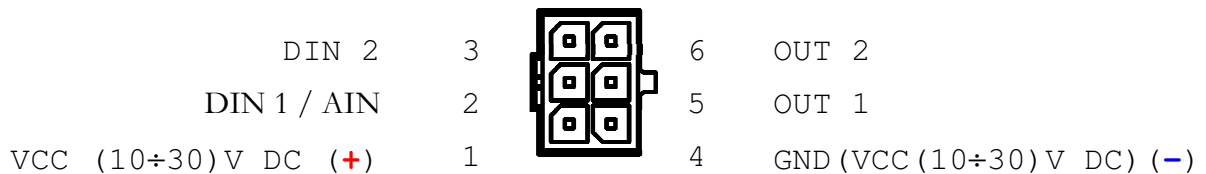

Figure 6 2x3 socket pinout

Table 3 Socket 2x3 pinout description. *- digital input status 0 ... ~2 V – FALSE; ~2,5 V... 30 V– TRUE

Pin Nr.	Pin Name	Description
1	VCC (10÷30) V DC (+)	Power supply for module. Power supply range (10÷30)V DC Energy consumption: GPRS: --- 200 mA r.m.s Max.
2	DIN 1 / AIN	Digital input, channel 1* / Analog input 0-30 V range
3	DIN 2	Digital input, channel 1*
4	GND (-)	Ground pin.
5	OUT 1	Digital output. Channel 1. Open collector output. Max. --- 150mA.
6	OUT 2	Digital output. Channel 2. Open collector output. Max. --- 150mA.

***** The described PINOUT is used only for FM3600_C1 hardware configuration!!!**

3.8 USB

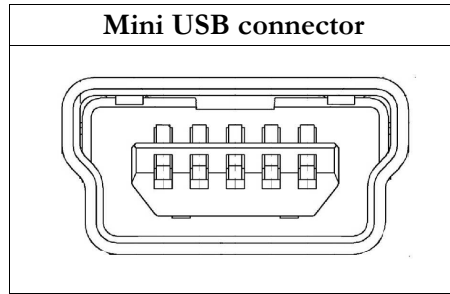

Figure 7 Mini USB type B connector

FM3600 connected to PC creates an STM Virtual COM Port, which can be used as a system port (to flash firmware and configure the device):

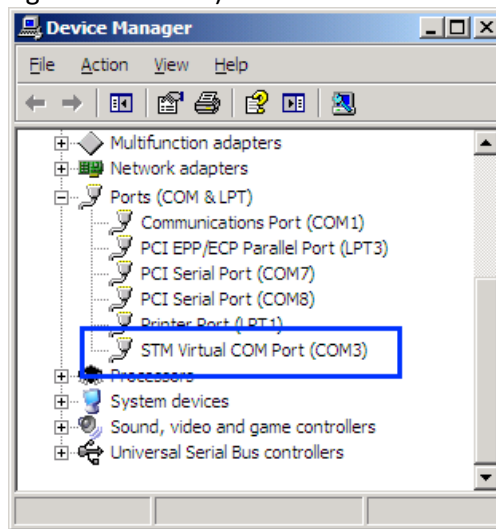
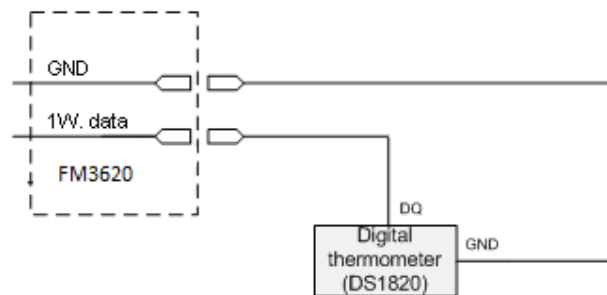

Figure 8 COM-Ports

3.9 Accessories

1 – Wire devices for FM3600_C2

One of the realized features is 1-Wire® data protocol, which enables connection of thermometer (DS1820, DS18S20 and DS18B20) and I-Button type: [DS1990A](#) (Figure 9 and Figure 10 show FM3600_C2 and 1-wire® device connection schemes).



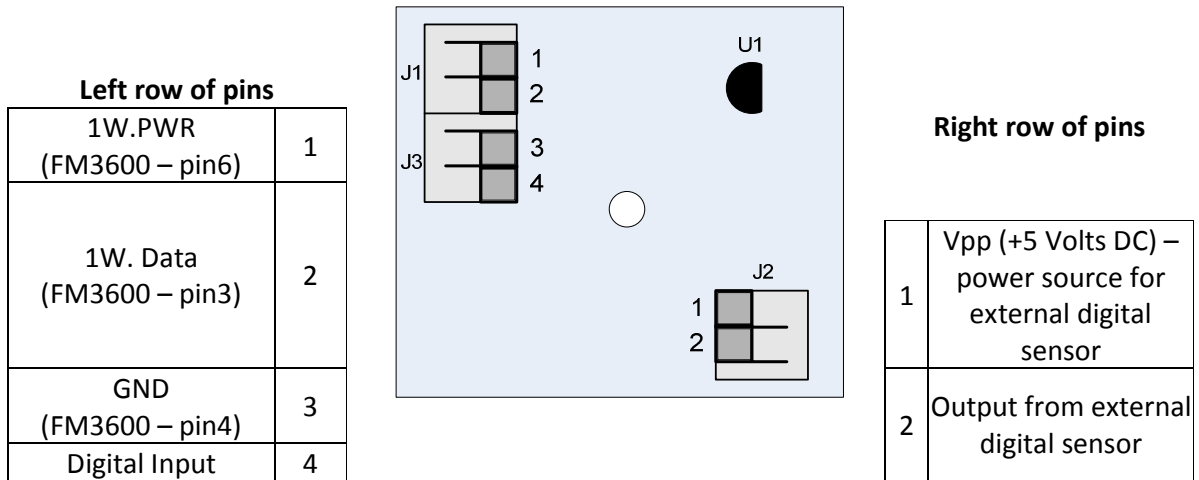

Figure 9 Digital thermometer DS1820 and TTJ100 connection scheme

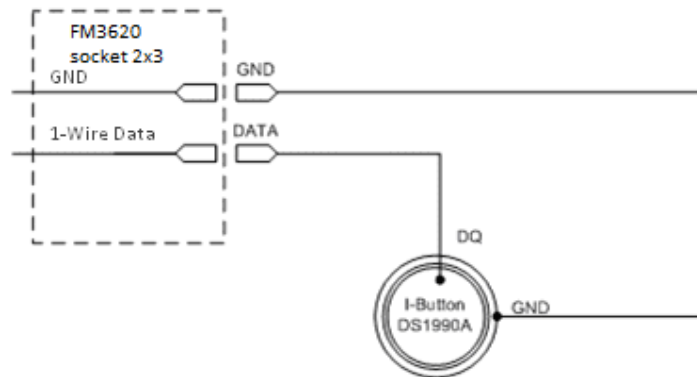

Figure 10 I-Button DS1990A connection scheme



Note: Teltonika does not provide any additional equipment like panic buttons, door sensors or others.

Fuel Tank sensors for FM3600_C1 or FM3600_C2

A fuel tank level sensor exists in most cars, which shows the approximate fuel level in the driver's indicator panel. It is possible to connect Analog input to FM3600_C1 or FM3600_C2 (if sensor returns analogue signal proportional to fuel level). As input shares the same PIN with Digital input 2, FM3600_C1 or FM3600_C2 must be configured to use only one of them. Figure 11 shows the connection scheme to the FM3600 and fuel tank sensor through Analog input 1. After the connection to the tank fuel level sensor, calibration is needed. Calibration is needed because most fuel tank sensors are not linear. Calibration is performed by measuring voltage dependence on volume of fuel in tank.

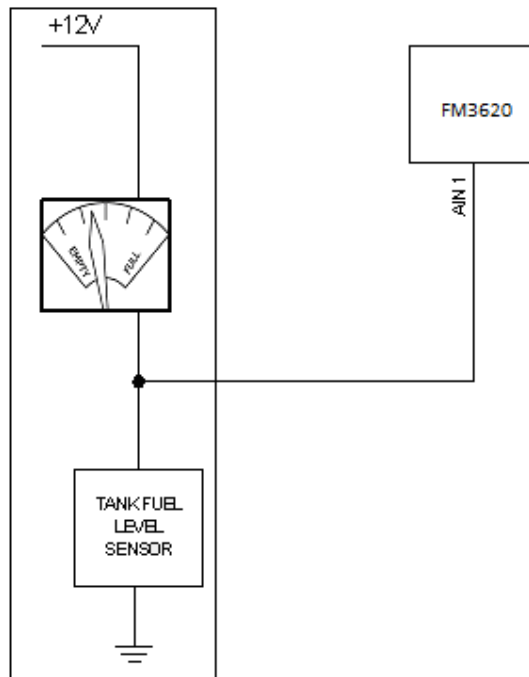

Figure 11 Fuel Tank sensor connection

Alarm buttons, door sensors, etc.

Alarm buttons, door sensors, ignition, etc. return two states: high or low voltage. Digital inputs are used to read this information. Figure below shows how to connect alarm button, door sensor, etc.

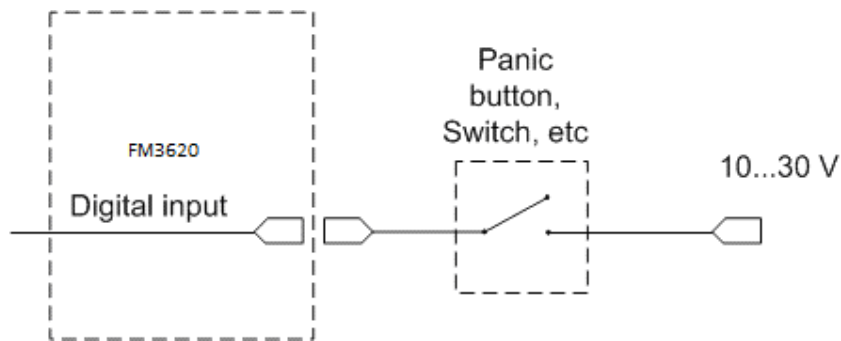

Figure 12 Panic button connection

In cases when sensor output signal is negative, an additional relay has to be installed to convert negative signal to positive.

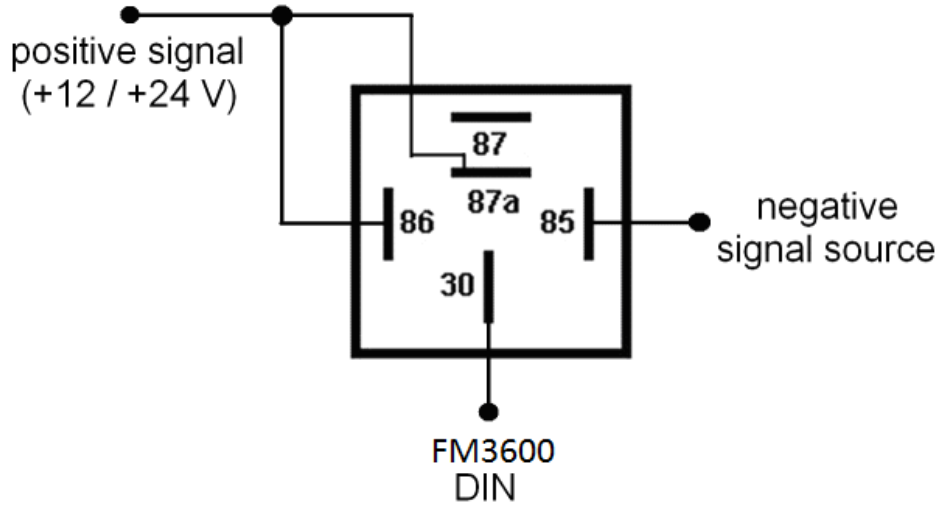

Figure 13 Inverting relay connection

Immobilizer relay

When connected as shown below, FM3600 disables engine starter when output is OFF. More details about relays can be found below.

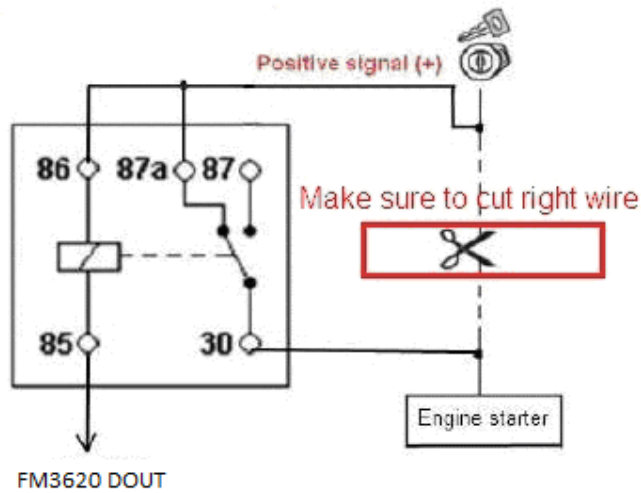

Figure 14 Immobilizer relay connection

Relays

An ordinary automotive relay is used to invert input signal or to immobilize engine starter. Note, that they are available as 12 V or 24 V.

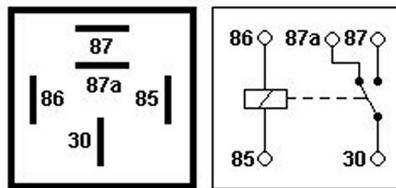

Figure 15 Automotive relay pinout

4 FIRMWARE

4.1 Updating firmware using USB cable

FM3600 functionality is always improving, new firmware versions are developed. Current module firmware version can be retrieved from Configurator.

Connect FM3600 to PC with the USB cable. Launch “Firmware Updater”, select COM port to which device is connected, click connect, and when IMEI and Firmware version fields are filled, start the update. Device needs some time to send IMEI and Firmware version, so do not be afraid if IMEI will not show up immediately, disconnect and after 1-2 minutes try to connect again. When starting update device will open link with updater. With link open device downloads firmware and starts installing. Wait thru all these screens as in Figure 17 for firmware to update. Update process may take up to several minutes.

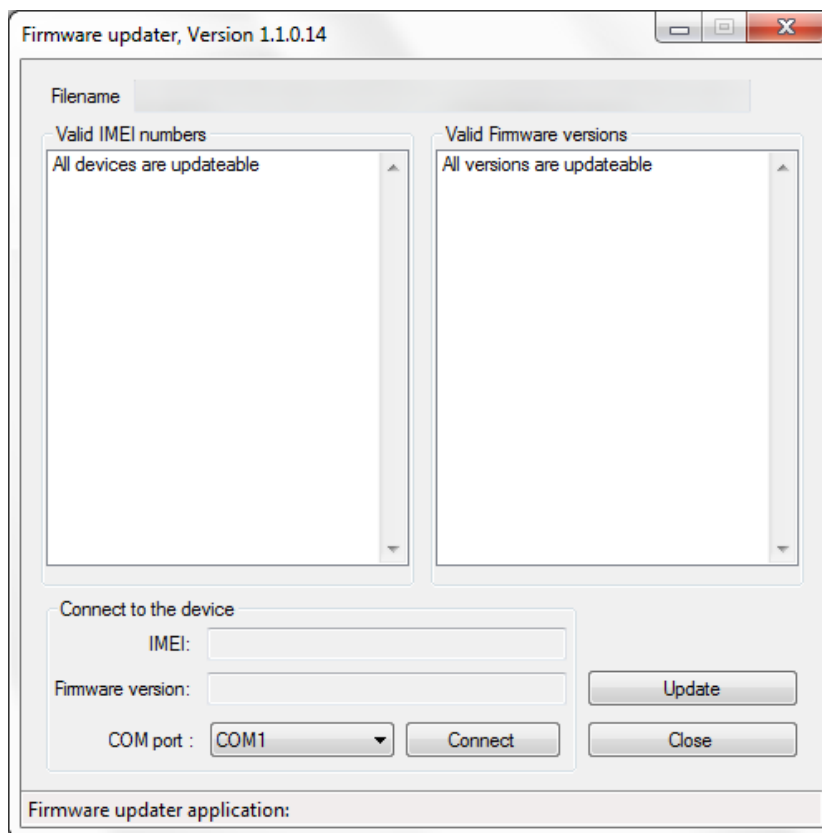

Figure 16 FM3600 firmware updater screen



FM3600 firmware is adapted to all hardware configurations. It automatically recognizes the hardware configuration and can be updated on every version without consequences

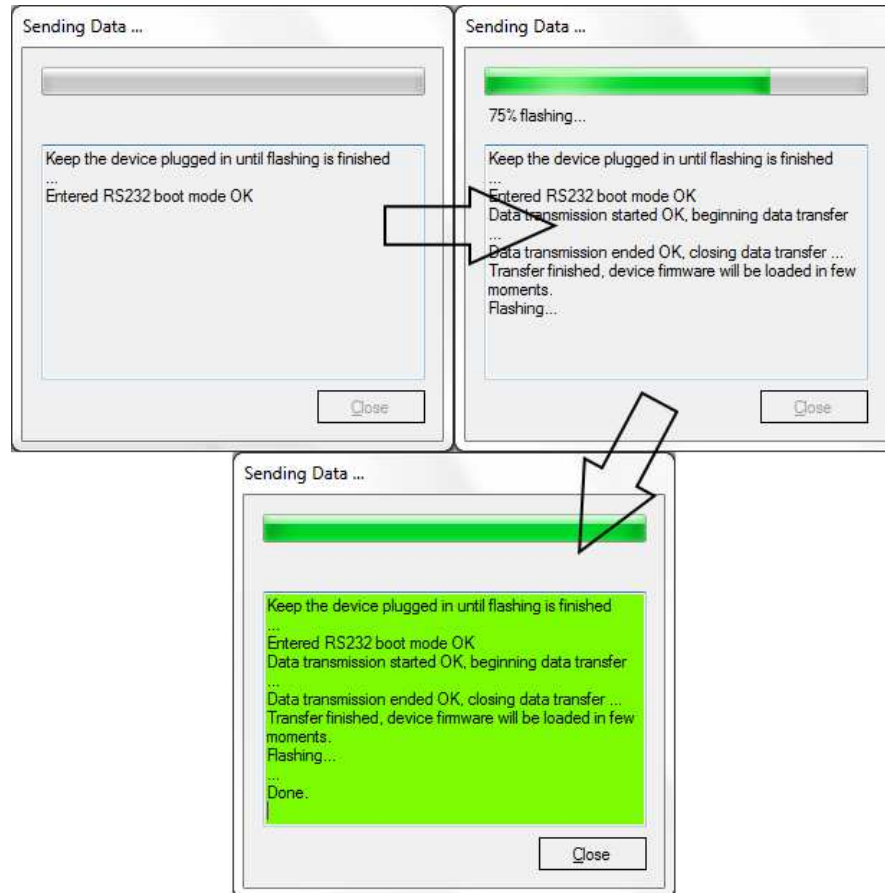

Figure 17 FM3600 firmware updating process

When you see a green table like in Figure 17, it means that the firmware is flashed to FM3600 successfully. You may now close the update window and start using your FM3600 device.

5 OPERATIONAL BASICS

5.1 Operational principals

FM3600 module is designed to acquire records and send them to server. Records contain GNSS data and I/O information. Module uses GNSS receiver to acquire GNSS data and is powered with four data acquire methods: time-based, distance-based, angle-based and speed-based method. Note, that if FM3600 loses connection to GNSS satellites, it continues to make records, however coordinate in these records remains the same (last known coordinate). Method's details are described in section 5.13. All data is stored in flash memory and later can be sent via 3G, GPRS or SMS. 3G mode is the most preferred data sending mode. If 3G coverage is not available the device sends data through GPRS network. FM3600 can also be configured to send data over GPRS and SMS only. This mode can be used to save bills or in the areas where 3G is not available. The least preferred data sending mode is SMS, which is mostly used in areas without GPRS coverage or GPRS usage is too expensive.

3G, GPRS and SMS settings are described in further sections. FM3600 communicates with server using special data protocol. Data protocol is described in "FMXXXX Protocols" document.

FM3600 can be managed by SMS commands. SMS Command list is described in SMS COMMAND LIST section. Module configuration can be performed over TCP or via SMS. Configuration parameters and modes are described in “FMXXX Protocols” document.

5.2 Sleep modes

5.2.1 Sleep mode

FM3600 is able to go to Sleep mode after configured interval of time. While in sleep mode, FM3600 sets GNSS receiver to sleep mode and it isn't making periodic records (only event records is being recorded with last known coordinate and sent to AVL server). As a result power usage decreases allowing saving vehicle battery.

FM3600 can enter sleep mode if **ALL** of these conditions are met:

- FM3600 has to be configured to work in Sleep mode and Sleep timeout set;
- Device must be synchronized time with GNSS satellites or via NTP;
- No movement by motion sensor is detected;
- Ignition (DIN1) is off;

FM3600 exits sleep mode when if **ONE** of following conditions are true:

- Movement by motion sensor is detected;
- Ignition (DIN1) is turned on;

5.2.2 Deep Sleep mode

While in deep sleep mode, FM3600 sets GNSS receiver to sleep mode and turns off GSM/GPRS/3G module (it is not possible to wake up device via SMS). Despite records with last known coordinate are being saved and send to AVL server (GSM/GPRS/3G module is turned on to send data and after that it is turned off again), power usage is decreased to save vehicle's battery. Note, that power saving depends on two configurable parameters: send period and min. record saving period.

FM3600 can enter deep sleep mode if **ALL** of these conditions are met:

- FM3600 has to be configured to work in Deep Sleep mode and Sleep timeout set;
- Device must be synchronized time with GNSS satellites or via NTP;
- No movement by motion sensor is detected;
- Ignition (DIN1) is off;
- Min. Record Saving Period (Data Acquisition Mode settings) must be bigger than Active Data Link Timeout parameter, that FM3600 could close GPRS/3G link.
- Send period (Data Acquisition Mode settings) minus Active Data Link Timeout must be more than 90 sec., that FM3600 could close GPRS/3G link for at least 90 sec.
- USB cable is not connected.

FM3600 exits deep sleep mode when if **ONE** of following conditions are true:

- Movement by motion sensor is detected;
- Ignition (DIN1) is turned on;
- USB cable is connected;



Note: In order to save 3G/GPRS traffic records saved in deep sleep mode do not contain below listed I/O elements information:
PDOP, HDOP, Odometer, Speedometer, iButton ID, Cell ID, Area Code, Temperature and GNSS power

5.3 Virtual odometer

Virtual odometer is used to calculate traveled distance in FM3600 as a separate I/O element. When FM3600 detects movement, it starts counting distance using GNSS signal: every second it checks current location and calculates distance between current and previous point. It keeps adding these intervals until it is time to make a record, then FM3600 records its location and adds odometer value, which is equal to the sum of all distances, measured every second. When record is made, odometer resets to zero and distance calculation starts all over again.

Virtual odometer as an I/O element can be also used with Trip feature, read chapters 5.4.2 and 5.14.2 for more details.

5.4 Features

Using available features can greatly increase FM3600 usability options.

5.4.1 Scenarios

Green Driving Scenario. Helps to prevent and inspect driver about harsh driving. Scenario continuously monitors: accelerating force, braking force and cornering angles. Warns driver if needed. DOUT1 or DOUT2 is controlled by scenario for user needs, for example buzzer or LED.

To save 3G/GPRS traffic Green Driving **event** will be **generated (included into sent records) only** when measured values are higher than those set in configuration, without additional I/O settings.

To prevent generating false events, harsh acceleration and harsh braking is monitored only when following conditions are fulfilled:

- Ignition is ON (DIN1 = 1)
- Vehicle speed is equal or higher than 10km/h

Harsh cornering is monitored only when following conditions are fulfilled:

- Ignition is ON (DIN1 = 1)
- Vehicle speed is equal or higher than 30km/h



Note: Green Driving Scenario is a factor on various cars and various drivers testing phase and can be subject to changes. Teltonika is constantly working on improvement of the functionality of the devices, and strongly recommends using the latest version of the firmware.

Over Speeding Scenario. Helps to prevent from exceeding fixed speed and inspects driver if needed. DOUT1 or DOUT2 is controlled by scenario for user needs, to manage buzzer, LED, etc.

Authorized Driving Scenario. Gives ability to use vehicle for 500 specific iButton owners (specified in iButton list). DOUT2 or DOUT1 is controlled by scenario for user needs, to manage buzzer, LED, etc.



Note: In order for Authorized driving to work properly, at least 1 iButton ID must be written to the iButton list.

Immobilizer Scenario. Vehicle can be used only if iButton is connected. In this scenario iButton list is not used; connect any iButton to pass Immobilizer security. DOUT2 or DOUT1 is controlled by scenario for user needs, to manage buzzer, LED, etc.

5.4.2 Trip

Trip customizable feature enables user extended monitoring of performed trips (from engine start at present location to engine stop at arrived location), log their start and stop points, view driven total distance⁴. Event will be **generated (included into send records) only** when trip starts and finishes. This feature is available on all FM3600 hardware versions without limitations.



Note: Scenarios and Trip features are activated (DOUTs are activated) only if DIN1=1 (ignition is on).

5.4.3 Geofencing

Geofencing is another feature which is highly customizable and can detect wherever car enters or leaves customized areas. More about Geofencing can be read in 5.14.3 chapter.

Auto Geofencing feature if enabled is activated automatically by turning off car ignition. Next time before driving user has to disable Auto Geofencing with iButton or by turning on car ignition. In case of theft car leaves Auto Geofencing zone without authorization high priority record to AVL application is sent automatically.

5.4.4 iButton list

iButton list is used to enter authorized iButton ID codes, which are used to authenticate driver in Authorized driving and Auto Geofencing options.

5.5 CONFIGURATION

5.6 Configurator

New FM3600 module has default factory settings. Settings should be changed according to your application and your GSM operator information.

FM3600 configuration is performed via FM3600 Configurator program. FM3600 Configurator version can be downloaded from <http://avl1.teltonika.lt/downloads/FM36/>. Contact sales manager to get the latest FM3600 Configurator version. FM3600 configurator

⁴ Continuous odometer – total driven distance, works only in TRIP mode. Continues distance is counted only for ONE trip. If trip is finished (stop point is detected), odometer resets to 0 (zero). Next trip will start counting from the beginning.

operates on Microsoft Windows OS and uses MS .Net Framework 3.5 or higher. Please ensure that MS .Net Framework 3.5 or later is installed on your PC before starting configurator. Latest MS .Net Framework version can be downloaded from official Microsoft web page.

Module configuration is performed over USB cable. Configuration process starts from starting FM3600 Configurator program and then connecting to FM3600 device via Connect button located on the top left corner of configurator. If connected successfully IMEI, Version fields which were empty, now are filled with certain numbers depending on Modem IMEI and firmware version of your device (figure below).

FM3600 has one user editable profile, which can be loaded from device, and saved. User can also revert to default settings, by pressing Load Defaults button. After any modification of configuration settings it has to be saved to FM3600 device, otherwise it will not be written to device.

FM3600 has 2 configuration modes: Recommended Configuration (Figure 18) and Advanced Configuration (Figure 19).

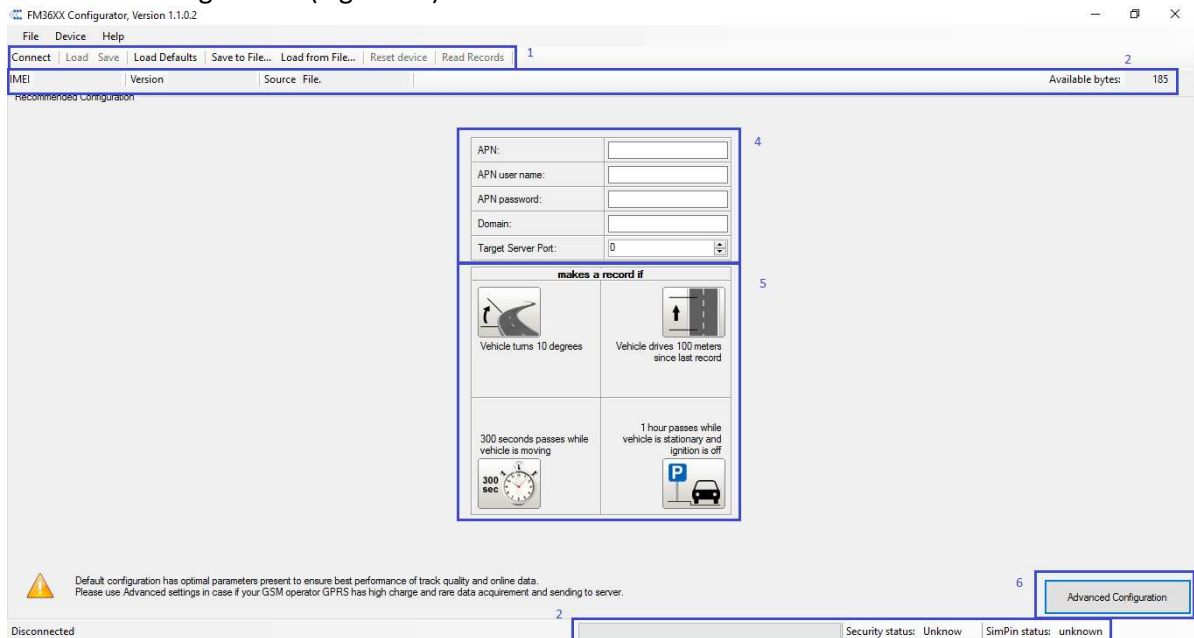

Figure 18 Recommended Configuration window

Recommended Configuration mode uses predefined data acquisition values. In this configuration mode it is only required to enter network parameters. In Advanced Configuration mode FM3600 is more configurable.

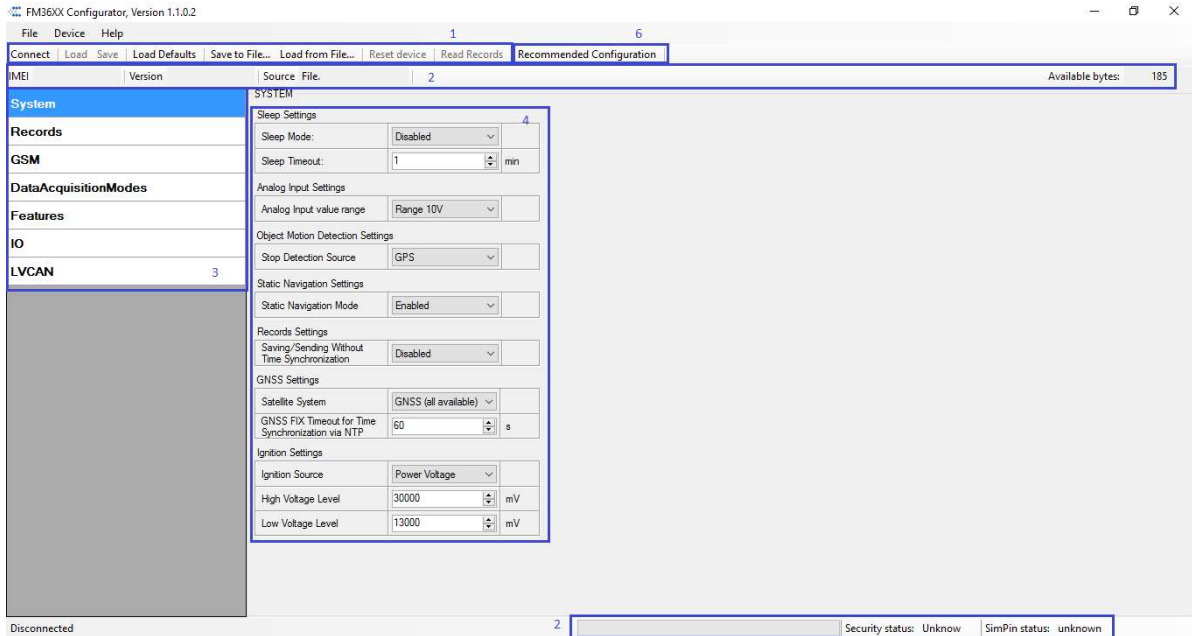

Figure 19 Configurator window

FM3600 Configurator is divided into main areas: 1 – main button area, 2 – information area, 3 – settings menu, 4 – parameters and values menu, 5 – recommended configuration values.

Button 6 is used to change between configuration modes.

Main Buttons description:

‘Connect’ – connects device

‘Load’ – reads configuration parameters from FM3600 Flash memory.

‘Save’ – saves configuration parameters to FM3600 Flash memory.

‘Load Defaults’ – loads default FM3600 settings that later can be modified. This procedure must be performed before entering new parameters.

‘Save to File...’ – allows user to save currently entered settings to .XML file, for later usage.

‘Load from File...’ – allows user to load configuration saved in .XML extension file.

‘Reset device’ – reboots FM3600 and displays processor firmware version.

Additional Buttons description:

‘Add Keyword’ / ‘Change Keyword’ / ‘Switch Security Off’ – buttons are used to protect configurator from unauthorized access to configuration.

Keyword is 4 – 10 symbol length. If keyword is set, every time user reconnects FM3600 to USB port, user will be asked to provide valid keyword when connecting FM3600 to configurator. User is given 5 attempts to enter keyword. After entering valid keyword, counter resets to 5.

If user disconnects FM3600 using ‘Disconnect’ button and does not disconnect from USB port, after reconnecting using ‘Connect’ button, configurator does not ask for keyword.



ATTENTION! If you have entered a keyword, disconnected from the configurator and then later connected again, you will need to enter the keyword that you have entered previously. If you have forgotten it, please contact your local sales manager.

5.7 Read records

When the FM3600 is working in offline mode, it can save up to 3854 records. Since these records are not sent to the server, they can be downloaded directly to connected computer using USB connection. When you connect FM3600 device, FM3600 Configurator appears with additional option "Read Records" (**Error! Reference source not found.**).

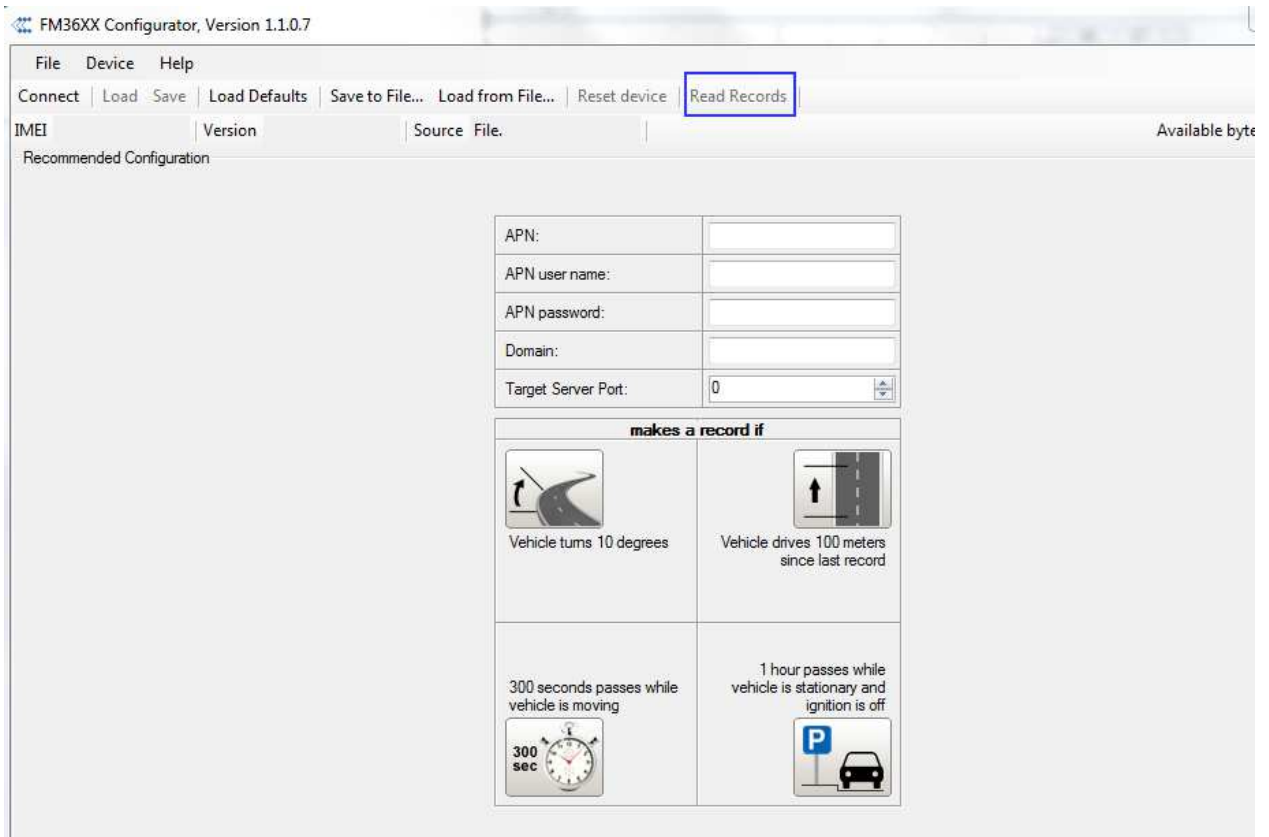

Figure 20 FM11YX Configurator window with FM3600M connected

After device is switched on, you have to wait 3 minutes for device to startup. Only then it is possible to download records. If the memory is fully filled, the records reading may take several minutes. After reading records, all records are deleted from the device memory. Data records are stored in a binary file on your PC. You can upload these records from file to TAVL server and access all the data from TAVL.

TAVL client application lets user to use the following features:

- Import data file saved from the device to the TAVL;
- Preview track of the imported data;

- Generate reports of the imported data.

More details on how to use TAVL application please refer to “TAVL3 application user manual v1.4” documentation or its later versions.



Figure 21 FM3600_sticker

FM3600 version can be still used as a standard FM3600. It can be configured to acquire and send data to server. It will be possible to store up to 3854 data records if GSM is not available at the moment. It will send data later when GPRS is available again. Note that FM3600 can have memory full of records. In such a case it will start deleting oldest records in order to save new ones. Sending all the data records to server may take some time. Sending 3854 records for FM3600 may take for about 5 hour (exact time may differ depending on GPRS/server load).

5.8 System settings

System settings have 7 configurable parameters:

- Deep sleep settings, where user can turn deep sleep on or off;
- Analog Input Settings, where user can choose analog input range 10 V or 30 V, depending on needed accuracy (lower range gives higher accuracy of measurements), and input voltage;
- Object Motion Detection Settings, where user can configure 3 ways how FM3600 will detect stopped movement, and change its working mode (for working modes, read section 5.13)
- Static navigation settings, where user can turn static navigation on or off;
- Records Settings, where user can enable or disable records when GPS is not available (no time synchronization);
- GNSS Settings, where user can choose satellite system and GNSS FIX Timeout Time (if after timeout there will not be synchronized time, it will be synchronized via NTP server).
- Ignition Source sets ignition triggered functionalities to be triggered by:
 - Power Voltage (if voltage is between High Voltage Level and Low Voltage Level the ignition is considered to be turned on);
 - Digital Input (DIN1 ON – ignition on, DIN1 OFF – ignition off);
 - Movement (if accelerometer/movement sensor detects movement then ignition is on, if movement stops – ignition is off).

Stop Detection Source	Vehicle on Stop mode	Vehicle Moving mode
Ignition (recommended)	If ignition (configured Ignition Source) is logic low	If ignition (configured Ignition Source) is logic high
Msensor (movement sensor)	Internal movement sensor does not detect movement	Internal movement sensor detects movement
GPS	GNSS fix is available and vehicle speed is lower than 5 km/h	GNSS fix is available and vehicle speed is higher than 5 km/h
	While GNSS fix is unavailable, Object Motion Detection Settings are working like in Msensor mode	

Static Navigation Mode is a filter, which filters out track jumps when the object is stationary. If Static navigation filter is disabled, it will apply no changes on GNSS data. If Static navigation filter is enabled, it will filter changes in GNSS position if no movement is detected (depends on Object Motion Detection Settings). It allows filtering GNSS jumps when object is parked (is not moving) and GNSS position is still traced.

Figure 22 System settings configuration

5.9 Records settings

Here user can modify if FM3600 device will send newest records first, meaning, that the most important thing is to know recent position of car, older records are being sent right after newest records arrive to AVL application.

Activate Data Link Timeout is used to set timeout of link between FM3600 and AVL application termination. If FM3600 has already sent all records it waits for new records before closing link. If new records are generated in the period of this timeout, and minimum count to send is reached, they are sent to AVL application. This option is useful when GSM operator charge for link activation.

Server Response Timeout is used to set time period waiting for response from server side.

Figure 23 Records settings configuration

5.10 GSM settings, GPRS part

'GPRS' defines main parameters for FM3600: GSM operator APN and GPRS username and password (optional – depending on operator), destination server IP and port, and allows to set protocol used for data transfers – TCP or UDP.

Yet user can choose if device will work only in GSM network, or it will prefer 3G network and switch to GSM only then 3G is absent.

Some operators use specific authentication for GPRS session – CHAP or PAP. If any of these is used, APN should be entered as 'chap:<APN>' or 'pap:<APN>'. I.e. if operator is using APN 'internet' with CHAP authentication, it should be entered as 'chap:internet'. Information about APN and authentication type should be provided by your GSM operator.

Figure 24 GPRS configuration

5.11 GSM settings, SMS part

Essential fields in 'SMS' part are 'Login' and 'Password'. The login and password are used with every SMS sent to FM3600. If login and password are not set, in every SMS sent to FM3600 device two spaces before command have to be used (<space><space><command>).

Command structure with set login and password:

<login><space><password><space><command>, example: “opa opa getgps”

Phone numbers have to be written in international standard, without using “+” or “00” signs in prefix. If no numbers are entered, configuration and sending commands over SMS are allowed from all GSM numbers.

SMS data sending settings – enable or disable **periodic** data and event SMS usage. This setting does not affect replies to SMS request messages – answers are always sent back to sender telephone number.

FM3600 can send binary SMS with 24-coordinates-in-one-SMS. It is used in areas where no GPRS coverage is available. Module collects data and sends to server binary SMS containing information about last 24 collected points. SMS sending schedule is set in SMS Week Time tab and used Time zone is set in SMS Time Zone. 24-Coordinates SMS decoding is described in device protocols documentation. Please contact Teltonika sale manager to find out more about protocols documentation purchase

The screenshot shows the 'SMS data sending Settings' configuration page. On the left is a navigation menu with categories: System, Records, GSM (with sub-items: > GPRS, > SMS, > SMS Events, > Operator list), DataAcquisitionModes, Features, IO, and LVCAN. The main content area includes:

- 'SMS data sending Settings' dropdown menu set to 'Disabled'.
- 'SMS login:' and 'SMS password:' input fields.
- 'SMS Week Time' input field.
- 'SMS Time Zone:' dropdown menu set to 'UTC-00:00'.
- 'Authorized phone numbers:' table with 10 rows (01-10) and a 'Phone Number' column. Row 01 is selected.
- 'SMS Events PreDefined Numbers' table with 10 rows (01-10) and a 'Phone Number' column. Row 01 is selected.

At the bottom of the tables, there is a note: (*Server Phone Number)

Figure 25 SMS configuration



Note: A mobile phone will not understand SMS with binary code, so sending it to a mobile phone is useless. When sending a binary SMS to a phone number, which is a server phone number, the server can interpret and understand binary code, so the data can be read and you can view it on the server.



SMS login and password and authorized number list are used to protect FM3600 module from unauthorized access. Module accepts messages only from a list of authorized numbers and with proper module login and password. Numbers must be without “+” or “00” prefix. If no authorized numbers are entered, module accepts messages from all numbers.

5.12 GSM settings, Operator list

Operators list – FM3600 can work in different modes (use different settings) according to the operator list defined. Operator list is used for Data Acquisition Mode switching (see chapter 5.13 Data Acquisition Mode settings for more details). Modes are changed based on 3G/GSM operator FM3600 is connected to.

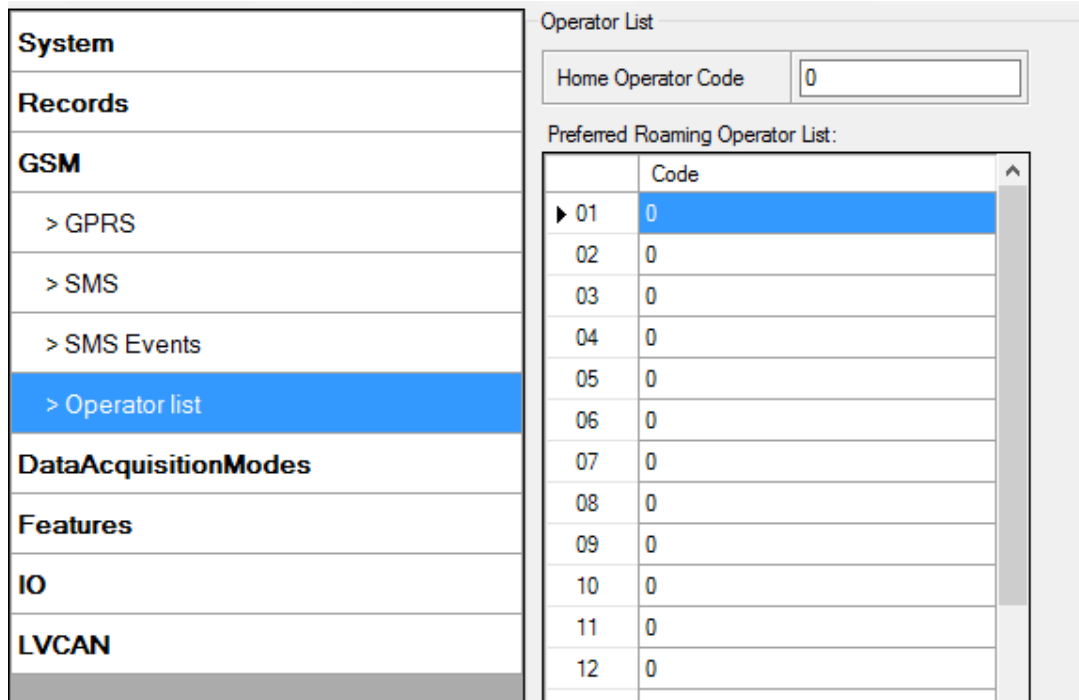

Figure 26 Operator list configuration

If operator list is left empty, it will allow using GPRS to any GSM operator. Please note that FM3600 will work in **Unknown mode only** (make sure it is configured to allow data sending – GPRS context is enabled).

5.13 Data Acquisition Mode settings

Data Acquisition Modes are an essential part of FM3600 device, it is also highly configurable.

By configuration user defines how records will be saved and sent. There are three different modes: Home, Roaming and Unknown. All these modes with configured data acquisition and send frequencies depend on current GSM Operator defined in Operator list (see section 5.12) and are switched when GSM operator changes (e.g. vehicle passes through country boarder).

If current GSM operator is defined as Home Operator, device will work in Home Data Acquisition mode, if current operator is defined as Roaming Operator, device will work in Roaming Data Acquisition mode, and if current operator code is not written in Operator list (but there is at least one operator code in the operator list), device will work in Unknown Acquisition mode.

This functionality allows having different AVL records acquire and send parameters values when object is moving or stands still. Vehicle moving or stop state is defined by Stop Detection Source parameter. There are 3 ways for FM3600 to switch between Vehicle on Stop and Vehicle Moving modes see section 0.

FM3600 allows having 6 different modes. Operational logic is shown in Figure 27.



If there are no operator codes entered into operator list, FM3600 will work in Unknown network mode ONLY.

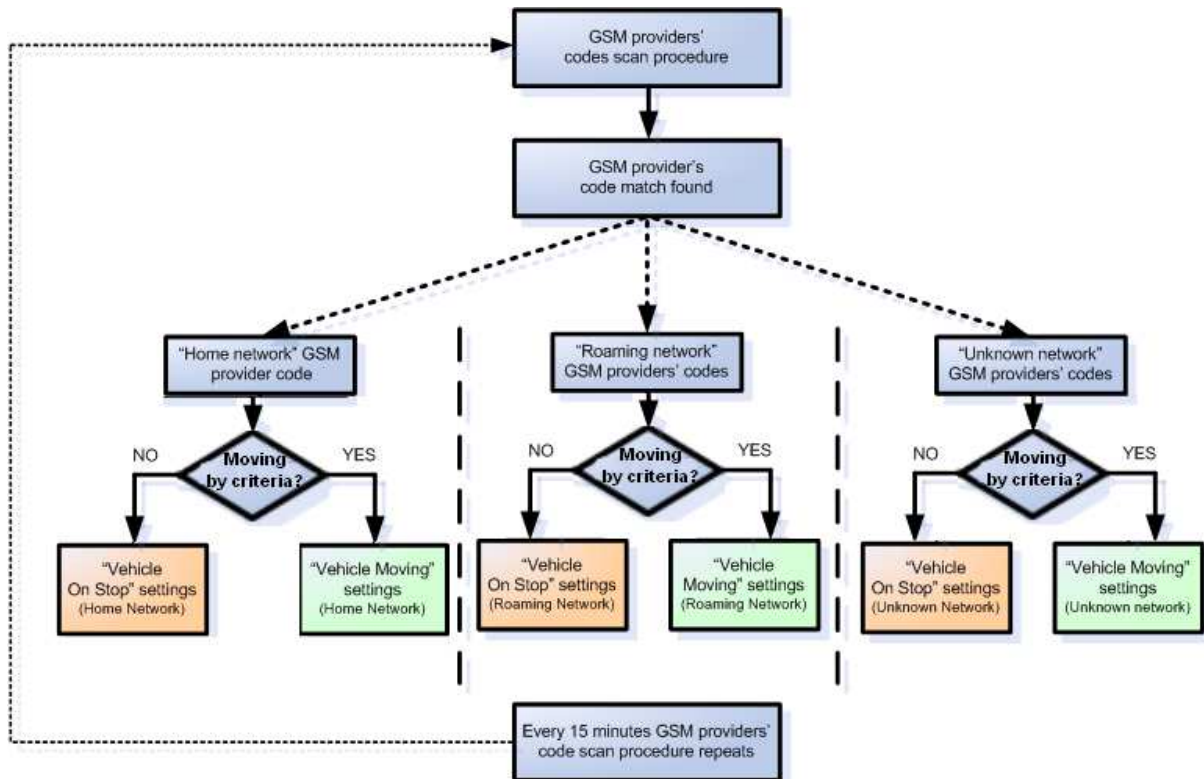

Figure 27 Data Acquisition Mode configuration

Operator search is performed every 15 minutes. Depending on current GSM operator, Home, Roaming or Unknown mode can be changed faster than every 15 minutes. This process is separate from operator search. Movement criteria are checked every second.

System Records GSM DataAcquisitionModes > Home > Roaming > Unknown Features IO LVCAN	Data Acquisition Modes : Home																																	
	<table border="1"> <thead> <tr> <th colspan="2">Vehicle on STOP</th> <th colspan="2">Vehicle MOVING</th> </tr> </thead> <tbody> <tr> <td>Min Period:</td> <td>600 sec.</td> <td>Min Period:</td> <td>30 sec.</td> </tr> <tr> <td></td> <td></td> <td>Min Distance:</td> <td>200 m.</td> </tr> <tr> <td></td> <td></td> <td>Min Angle:</td> <td>20 deg.</td> </tr> <tr> <td>Min Saved Records:</td> <td>1</td> <td>Min Speed Delta:</td> <td>0 km/h</td> </tr> <tr> <td>Send Period:</td> <td>1 sec.</td> <td>Min Speed Source:</td> <td>GPS</td> </tr> <tr> <td></td> <td></td> <td>Min Saved Records:</td> <td>1</td> </tr> <tr> <td></td> <td></td> <td>Send Period:</td> <td>1 sec.</td> </tr> </tbody> </table>		Vehicle on STOP		Vehicle MOVING		Min Period:	600 sec.	Min Period:	30 sec.			Min Distance:	200 m.			Min Angle:	20 deg.	Min Saved Records:	1	Min Speed Delta:	0 km/h	Send Period:	1 sec.	Min Speed Source:	GPS			Min Saved Records:	1			Send Period:	1 sec.
	Vehicle on STOP		Vehicle MOVING																															
	Min Period:	600 sec.	Min Period:	30 sec.																														
			Min Distance:	200 m.																														
			Min Angle:	20 deg.																														
	Min Saved Records:	1	Min Speed Delta:	0 km/h																														
	Send Period:	1 sec.	Min Speed Source:	GPS																														
			Min Saved Records:	1																														
			Send Period:	1 sec.																														
<div style="text-align: center;">GPRS Week Time</div>																																		
Data Acquisition Modes : Roaming																																		
<table border="1"> <thead> <tr> <th colspan="2">Vehicle on STOP</th> <th colspan="2">Vehicle MOVING</th> </tr> </thead> <tbody> <tr> <td>Min Period:</td> <td>600 sec.</td> <td>Min Period:</td> <td>1200 sec.</td> </tr> <tr> <td></td> <td></td> <td>Min Distance:</td> <td>1000 m.</td> </tr> <tr> <td></td> <td></td> <td>Min Angle:</td> <td>30 deg.</td> </tr> <tr> <td>Min Saved Records:</td> <td>10</td> <td>Min Speed Delta:</td> <td>0 km/h</td> </tr> <tr> <td>Send Period:</td> <td>600 sec.</td> <td>Min Speed Source:</td> <td>GPS</td> </tr> <tr> <td></td> <td></td> <td>Min Saved Records:</td> <td>10</td> </tr> <tr> <td></td> <td></td> <td>Send Period:</td> <td>600 sec.</td> </tr> </tbody> </table>		Vehicle on STOP		Vehicle MOVING		Min Period:	600 sec.	Min Period:	1200 sec.			Min Distance:	1000 m.			Min Angle:	30 deg.	Min Saved Records:	10	Min Speed Delta:	0 km/h	Send Period:	600 sec.	Min Speed Source:	GPS			Min Saved Records:	10			Send Period:	600 sec.	
Vehicle on STOP		Vehicle MOVING																																
Min Period:	600 sec.	Min Period:	1200 sec.																															
		Min Distance:	1000 m.																															
		Min Angle:	30 deg.																															
Min Saved Records:	10	Min Speed Delta:	0 km/h																															
Send Period:	600 sec.	Min Speed Source:	GPS																															
		Min Saved Records:	10																															
		Send Period:	600 sec.																															
<div style="text-align: center;">GPRS Week Time</div>																																		
Data Acquisition Modes : Unknown																																		
<table border="1"> <thead> <tr> <th colspan="2">Vehicle on STOP</th> <th colspan="2">Vehicle MOVING</th> </tr> </thead> <tbody> <tr> <td>Min Period:</td> <td>3600 sec.</td> <td>Min Period:</td> <td>300 sec.</td> </tr> <tr> <td></td> <td></td> <td>Min Distance:</td> <td>100 m.</td> </tr> <tr> <td></td> <td></td> <td>Min Angle:</td> <td>10 deg.</td> </tr> <tr> <td>Min Saved Records:</td> <td>1</td> <td>Min Speed Delta:</td> <td>0 km/h</td> </tr> <tr> <td>Send Period:</td> <td>1 sec.</td> <td>Min Speed Source:</td> <td>GPS</td> </tr> <tr> <td></td> <td></td> <td>Min Saved Records:</td> <td>1</td> </tr> <tr> <td></td> <td></td> <td>Send Period:</td> <td>1 sec.</td> </tr> </tbody> </table>		Vehicle on STOP		Vehicle MOVING		Min Period:	3600 sec.	Min Period:	300 sec.			Min Distance:	100 m.			Min Angle:	10 deg.	Min Saved Records:	1	Min Speed Delta:	0 km/h	Send Period:	1 sec.	Min Speed Source:	GPS			Min Saved Records:	1			Send Period:	1 sec.	
Vehicle on STOP		Vehicle MOVING																																
Min Period:	3600 sec.	Min Period:	300 sec.																															
		Min Distance:	100 m.																															
		Min Angle:	10 deg.																															
Min Saved Records:	1	Min Speed Delta:	0 km/h																															
Send Period:	1 sec.	Min Speed Source:	GPS																															
		Min Saved Records:	1																															
		Send Period:	1 sec.																															
<div style="text-align: center;">GPRS Week Time</div>																																		

Figure 28 Data Acquisition Mode configuration

‘Min Saved Records’ defines minimum number of coordinates and I/O data that should be transferred with one connection to server. If FM3600 does not have enough coordinates to send to server, it will check again after time interval defined in ‘Sending Period’

Send period – GPRS data sending to server period. Module makes attempts to send collected data to server every defined period. If it does not have enough records (depends on parameter Min. Saved Records described above), it tries again after defined time interval.

GPRS Week Time tab – most GSM billing systems charge number of bytes (kilobytes) transmitted per session. During the session, FM3600 makes connection and transmits data to a

server. FM3600 tries to handle the session as much as possible; it never closes session by itself. Session can last for hours, days, weeks or session can be closed after every connection in certain GSM networks – this depends on GSM network provider. GPRS Context Week Time defines session re-establish schedule if session was closed by network. New GPRS context is opened if time is 10 minutes till time checked in table. Therefore if all boxes are checked, FM3600 is able to open new connection anytime. At scheduled time match FM3600 checks for GPRS session activity. If GPRS session is alive, FM3600 sends data to server according to Send period parameter. If it is not, FM3600 checks if it is able to re-establish the session.

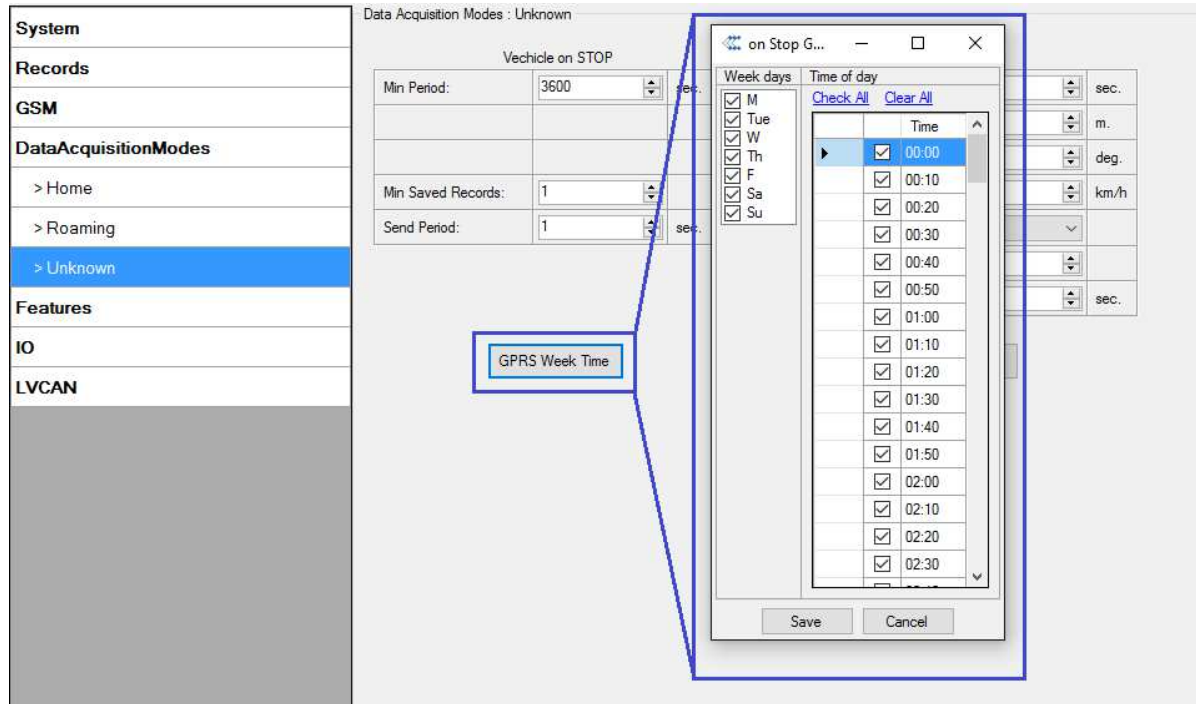

Figure 29 GPRS Week Time configuration

Device checks if the time between last saved record and current time is equal or higher than Time based acquire interval. If so, FM3600 saves record to memory. If not, FM3600 checks if the distance from last record to current record is equal or higher than Distance based acquire interval. If so, saves the record to memory. If not and speed is higher than 10km/h, then FM3600 checks if angle difference between last record and current record is equal or higher than Angle based acquire value. If so, saves the record to memory. These checks are performed every second.



Note: Keep in mind that FM3600 operates in GMT:0 time zone, without daylight saving.

FM3600 is able to collect records using four methods at the same time: time, distance, angle and speed based data acquisition:

Time based data acquiring (Min. period) – records are being acquired every time when defined interval of time passes. Entering zero disables data acquisition depending on time.

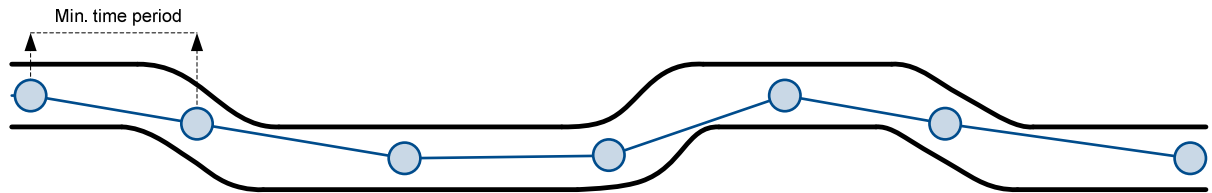

Distance based data acquiring (Min. distance) – records are being acquired when the distance between previous coordinate and current position is greater than defined parameter value. Entering zero disables data acquisition depending on distance.

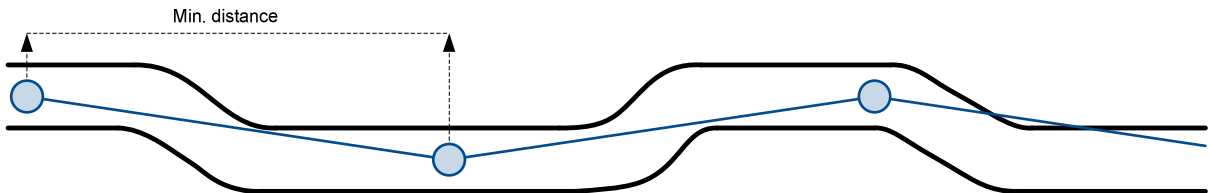

Angle based data acquiring (Min. angle) – records are being acquired when angle difference between last recorded coordinate and current position is greater than defined value. Entering zero disables data acquisition depending on angle.

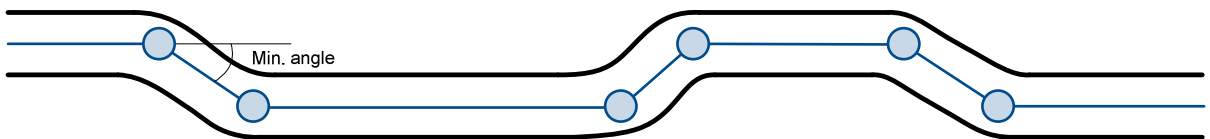

Speed based data acquiring (Min. speed delta) – records are being acquired when speed difference between last recorded coordinate and current position is greater than defined value. Entering zero disables data acquisition depending on speed.

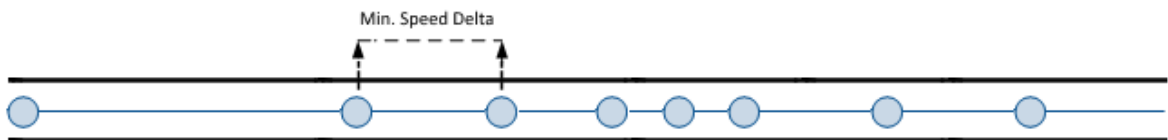

5.14 Features settings

For more information about available Scenarios, Trip, Geofencing and iButton list, refer to 5.4 chapter.

5.14.1 Scenarios settings

In Scenarios window five different scenarios are available: Green driving, Over Speeding, Immobilizer, iButton List checking and Jamming . All scenarios can use DOUT together, but if DOUT1 is assigned to Immobilizer, other scenarios can't control it.

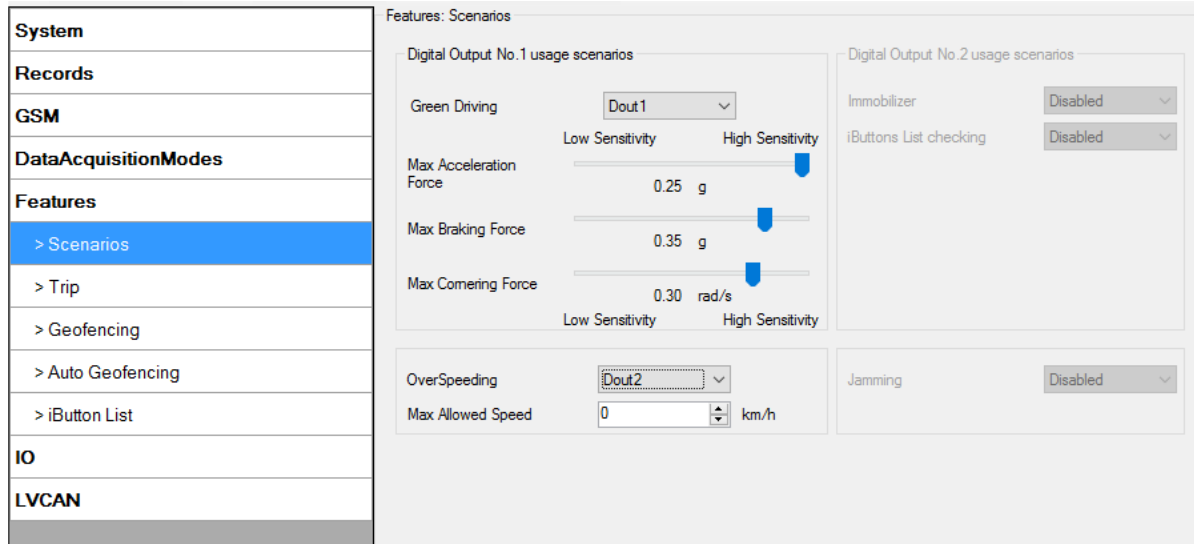

Figure 30 Scenarios configuration

Digital Output (open drain grade) usage in scenarios:

- Green Driving
 - DOUT1 is ON (if selected DOUT1) for:
 - 3sec. if detected value is over (0; 30] % from preconfigured allowed value
 - 5sec. if detected value is over (30; 50] % from preconfigured allowed value
 - 7sec. if detected value is over (50; -] % from preconfigured allowed value
 After period of time DOUT1 is turned OFF.

- Over Speeding
 - DOUT1 is ON(if selected DOUT1), while vehicle speed exceeds parameter value. DOUT1 is activated until current speed decreases below parameter value.

- Jamming detection (if selected DOUT1)
 - DOUT1 is ON, while modem is fixing radio frequency jamming. After jamming is over, DOUT1 is deactivated.

- Authorized driving (if selected DOUT2)
 - DOUT2 is continuously OFF. DOUT2 turns ON if Ignition turns ON (configured Ignition Source =1). After authorizing iButton (iButton ID is read and it matches the ID from the iButton list), DOUT2 turns OFF. After successful authorization ignition can be turned OFF (configured Ignition Source =0) for no longer than 30 seconds, otherwise authorization must be repeated.

- Immobilizer (if selected DOUT2)
 - DOUT2 is continuously OFF. DOUT2 turns ON if Ignition turns ON (configured Ignition Source =1). After iButton ID is read (any iButton is attached), DOUT2 turns OFF. After iButton

identification, ignition can be turned OFF (configured Ignition Source =0) for no longer than 30 seconds, otherwise immobilizer must be repeated.

5.14.2 Trip settings

Trip window offers user to configure Trip feature. If Trip is enabled configuration of parameters are enabled.

Start Speed – GNSS speed has to be greater than the specified Start Speed in order to detect Trip Start.

Ignition Off Timeout – timeout to wait if ignition was off, to detect Trip stop.

Continuous distance counting – Not or Continuous can be chosen. For this feature I/O Odometer must be enabled (see Figure 31).

If I/O Odometer is enabled and Continuous distance counting variable is set to Continuous, **Trip distance** is going to be counted continuously (**from Trip start to Trip stop**). This value is written to I/O Odometer value field. When Trip is over and next Trip begins, Odometer value is reset to zero. When the next trip starts counting continuously starts from the beginning again.

If I/O Odometer is enabled and Continuous Distance Counting variable is set “Not”, then the distance is going to be counted only between every record made. This value is written to I/O Odometer value field and reset to zero every new record until Trip stops. If later all Odometer values are summed up manually, the user gets the distance driven during the whole period of the Trip.

System	Features: TRIP		For distance counting IO odometer must be enabled IO elements	
Records	Trip start/stop detection	Disabled		
GSM	Start Speed:	5		km/h
DataAcquisitionModes	Ignition Off Timeout	60		sec
Features	Trip continuous distance counting	Not		
> Scenarios				
> Trip				
> Geofencing				

Figure 31 Trip configuration

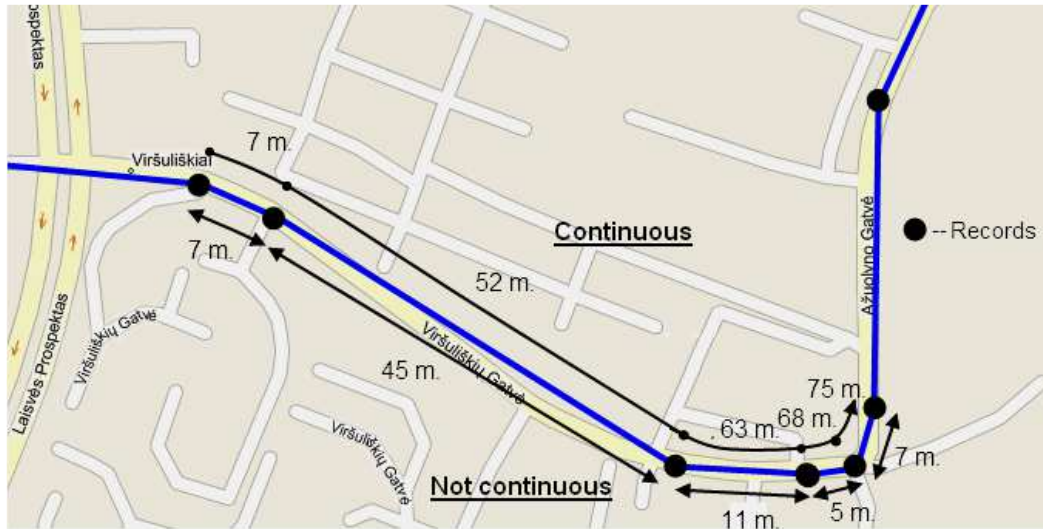

Figure 32 Trip continuous distance counting parameter example

5.14.3 Geofencing settings

FM3600 has 5 configurable Geofence zones and it can generate an event when defined Geofence zone border is crossed.

Frame border – frame border is an additional border around Geofence zone. It is additional area around defined zone used to prevent false event recording when object stops on the border of the area and because of GNSS errors some records are made inside area and some – outside. Event is generated only when both borders are crossed. See Figure 33 for details: track 1 is considered to have entered the area while track 2 is not.

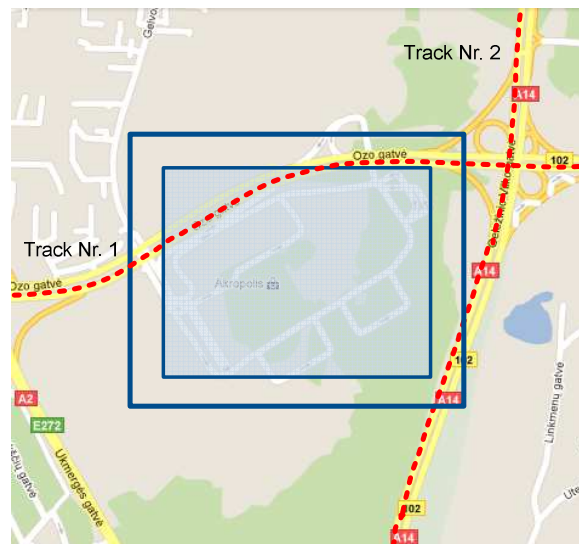

Figure 33 Geofence border

Shape – can be rectangle or circle

Priority – priority of Geofence event: low, high or panic. These levels define priority of event information sending to server. See I/O element description for more details about priorities.

Generate event (On entrance, On exit, On Both) – choose when record will be generated;

X1 – geofence zone left bottom corner X coordinate (longitude);

- Y1 – geofence zone left bottom corner Y coordinate (latitude);
- X2 or R – geofence zone upper right corner X coordinate (longitude) or radius of circle when Circular zone is used (radius in meters);
- Y2 – geofence zone upper right corner Y coordinate (latitude);

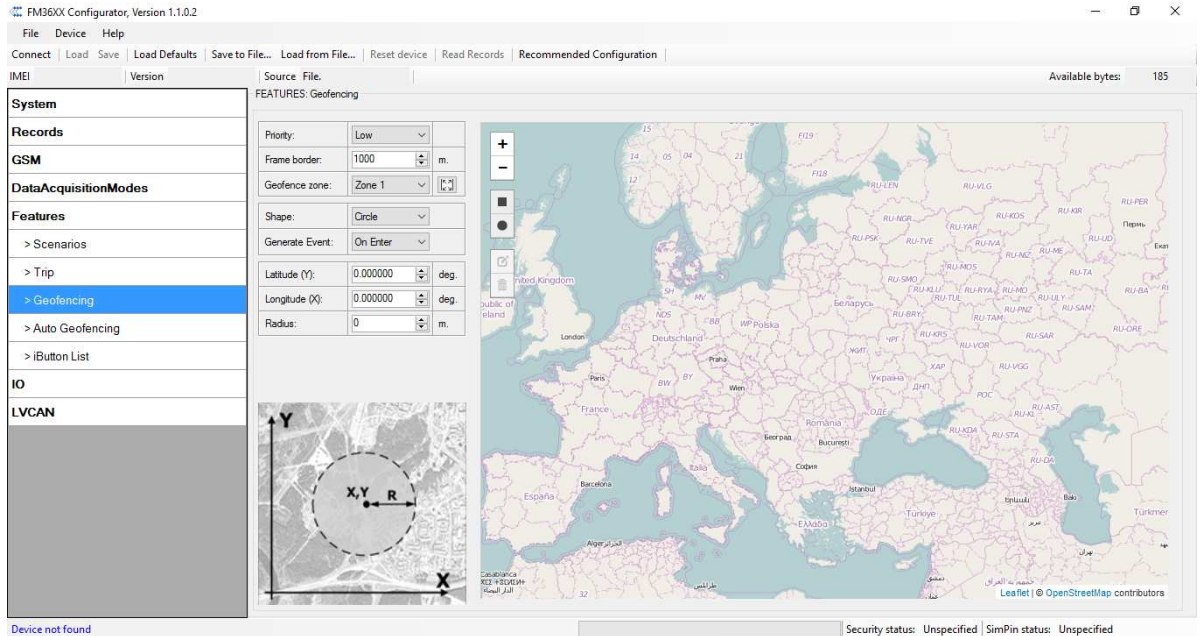

Figure 34 Geofence configuration

AutoGeofencing settings

AutoGeofence – the last known position after movement = off. If your car's being taken away – you can be notified. The shape and size of the geofence zones are parameters. When object will leave geofence zone device will trigger an asynchronous message.

AutoGeofencing option can be configured by following parameters visible in Figure 35 below.

Activation TMO – Time period before Geofence is activated after vehicle stops.

Deactivate By:

Ignition – If ignition (configured Ignition Source) becomes high it will disable AutoGeofence Zone.

iButton – if iButton is attached it will disable AutoGeofence Zone.

Edit iButton List – if list is not empty, attached iButton is tested against an iButton list, if match is found AutoGeofence zone is disabled.

Priority – Priority of generated event, which will be applied to saved record.

Exit Event – Event generation on Geofence exit.

On Both – Event generation on Geofence exit.

Note that AutoGeofencing does not require entering coordinates, instead it requires GNSS visibility. If vehicle stopped and activation timeout has passed, an AutoGeofence will be created around vehicle's last position with set Radius value. AutoGeofence event generation works the same as Geofencing mentioned above.

System	FEATURES: Auto Geofencing	
Records	Priority	Disabled <input type="button" value="v"/>
GSM	Activation timeout	60 <input type="button" value="up"/> <input type="button" value="down"/>
DataAcquisitionModes	Deactivate By	Ignition <input type="button" value="v"/>
Features	Edit iButtons List	iButtons <input type="button" value="v"/>
> Scenarios	Generate Event	On Both <input type="button" value="v"/>
> Trip	Radius	100 <input type="button" value="up"/> <input type="button" value="down"/> m.
> Geofencing		
> Auto Geofencing		
> iButton List		

Figure 35 Geofence configuration



Note: FM3600 operates GMT:0 time without daylight saving.

5.14.4 SMS events

SMS events functionality allows FM3600 to send a configured SMS when an event is triggered. This event can be triggered by:

- Green Driving
- OverSpeeding
- Authorized Driving
- Immobilizer
- Trip start/stop
- Geofence
- AutoGeofence
- I/O event

When any of the above events is triggered, FM3600 sends a configured SMS message to a defined phone number. If SMS events is activated, but there are no numbers defined in SMS events PreDefined Numbers list (Figure 36), then the device will not send any messages.

Figure 36 SMS Events PreDefined Numbers list

The sent SMS messages format is according to:

“Date Time EventText”

For example, if FM3600 is configured to send an SMS (Figure 37), when Digital Input 1 reaches High level, with priority High and configured to generate event on both range enter and exit (Figure 38), then the sent SMS is:

“2012/6/7 12:00:00 Digital Input 1”

Figure 37 Configured Digital Input 1 SMS Event

System	I/O						
Property Input	Enabled	Priority	Low Level	High Level	Generate Event	Averaging Constant	
Digital input 1	<input checked="" type="checkbox"/>	High	0	1	On Both	10	
Digital input 2	<input type="checkbox"/>	Disabl	0	0	Monitoring	2	
Analog input 1	<input type="checkbox"/>	Disabl	0	0	Monitoring	2	
Digital output 1	<input type="checkbox"/>	Disabl	0	0	Monitoring	10	
Digital output 2	<input type="checkbox"/>	Disabl	0	0	Monitoring	10	
GNSS PDOP	<input type="checkbox"/>	Disabl	0	0	Monitoring	10	
GNSS HDOP	<input type="checkbox"/>	Disabl	0	0	Monitoring	10	
External voltage	<input type="checkbox"/>	Disabl	10000	30000	On Exit	10	
GNSS power	<input type="checkbox"/>	Disabl	0	0	Monitoring		
Movement sensor	<input type="checkbox"/>	Disabl	0	0	Monitoring	10	

Figure 38 Configured Digital Input 1 to generate event on both range enter and exit

The SMS Text field can be altered and any text can be entered. Maximum message length is 90 symbols (numbers, letters and symbols in ASCII, except for comma “,”).



ATTENTION!

If FM3600 is in Deep Sleep mode and SMS event occurs with LOW priority (which does not wake up FM3600), then the device does not send the message. It is saved in device memory until it wakes up from Deep Sleep mode and GSM modem starts working normally. After it wakes up, all the messages that are saved in memory will be sent, but keep in mind that only 10 messages can be saved in memory – all other messages will not be saved, until there is room in device memory.

5.14.4.1 SMS events configuration

Scenarios

To configure SMS events for scenarios, open Scenarios window and Enable desired scenario. Then go to GSM ->SMS -> SMS events window and activate SMS event for Enabled scenario. Figure 39 shows how to enable Green Driving and Immobilizer SMS Events.

System	Features: Scenarios	
Records	Digital Output No.1 usage scenarios	Digital Output No.2 usage scenarios
GSM	Green Driving <input type="checkbox"/> Dout1	Immobilizer <input type="checkbox"/> Dout2
DataAcquisitionModes	Low Sensitivity High Sensitivity	iButtons List checking <input type="checkbox"/> Disabled
Features	Max Acceleration Force 0.25 g	
> Scenarios	Max Braking Force 0.35 g	
> Trip	Max Cornering Force 0.30 rad/s	
> Geofencing	Low Sensitivity High Sensitivity	
> Auto Geofencing	OverSpeeding <input type="checkbox"/> Disabled	Jamming <input type="checkbox"/> Disabled
> iButton List	Max Allowed Speed 0 km/h	
IO		
LVCAN		

Figure 39 Scenarios SMS event configuration

System	SMS Events	Enable	SMS Number	SMS Text	
Records	Trip distance	<input type="checkbox"/>	37061234567	LVC Trip Distance	
	Tachograph vehicle speed	<input type="checkbox"/>	37061234567	LVC Tacho Vehicle Speed	
GSM	Tachograph driver card presence	<input type="checkbox"/>	37061234567	LVC Tacho Driver Card Presence	
	> GPRS				
	> SMS				
	> SMS Events				
	> Operator list				
	DataAcquisitionModes				
	Features				
	IO				
	LVCAN	GreenDriving	<input checked="" type="checkbox"/>	37061234567	Green Driving
		Overspeeding	<input type="checkbox"/>	37061234567	OverSpeeding
Authorized Driving		<input type="checkbox"/>	37061234567	Authorized Driving	
Immobilizer		<input checked="" type="checkbox"/>	37061234567	Immobilizer	
Trin		<input type="checkbox"/>	37061234567	Trin	

Figure 40 Scenarios SMS event configuration

When any of the scenarios events occurs, a text message will be sent to the predefined number.

Trip

In order to configure Trip SMS events click on Trip window and Enable Trip feature (Figure 41). Then go to GSM -> SMS -> SMS Events settings and Enable Trip SMS event. After enabling SMS Events (Figure 42), trip event will be triggered and message sent, when Trip starts (GNSS speed exceeds the speed in Start Speed (ex. 5 km/h) and when Trip stops, that is ignition is turned off longer then the time written in Ignition Off Timeout (ex. 60 seconds).

System	Features: TRIP
Records	<div style="border: 1px solid blue; padding: 5px;"> <p>TRIP START STOP DETECTION</p> <p>Enable <input type="checkbox"/></p> <p>Start Speed: 5 km/h</p> <p>Ignition Off Timeout: 60 sec</p> <p>Trip continuous distance counting: Not</p> </div>
GSM	<p>For distance counting IO odometer must be enabled</p> <p><input type="button" value="IO elements"/></p>
DataAcquisitionModes	
Features	
> Scenarios	
> Trip	

Figure 41 Trip Start/Stop SMS event configuration

SMS Events			
Description	Enable	SMS Number	SMS Text
Authorized Driving	<input type="checkbox"/>	37067812345	Over speeding
Immobilizer	<input type="checkbox"/>	37067812345	Authorized Driving
Trip	<input checked="" type="checkbox"/>	37067812345	Immobilizer
Geofence 1	<input type="checkbox"/>	37067812345	Trip
Geofence 2	<input type="checkbox"/>	37067812345	Geofence Zone 1
			Geofence Zone 2

Figure 42 Trip Start/Stop SMS event configuration

Geofence

Geofence SMS event is triggered and message sent when the device exits and/or enters a configured Geofence zone. The Geofence zone must be configured to generate an event On Exit, On Enter or On Both (Figure 43). If No Event is selected, then it is not possible to turn on SMS events. If several zones are created then SMS events can be turned on separately for each zone entering different text message.

<p>System</p> <p>Records</p> <p>GSM</p> <p>DataAcquisitionModes</p> <p>Features</p> <ul style="list-style-type: none"> > Scenarios > Trip <li style="background-color: #0070C0; color: white;">> Geofencing > Auto Geofencing 	<p>FEATURES: Geofencing</p> <p>Priority: <input type="text" value="Low"/></p> <p>Frame border: <input type="text" value="1000"/> m.</p> <p>Geofence zone: <input type="text" value="Zone 1"/></p> <p>Shape: <input type="text" value="Circle"/></p> <p>Generate Event: <input type="text" value="On Both"/></p> <p>Latitude (Y): <input type="text" value="0.000000"/> deg.</p> <p>Longitude (X): <input type="text" value="0.000000"/> deg.</p> <p>Radius: <input type="text" value="0"/> m.</p>
--	---

Figure 43 Geofence SMS event configuration

Geofence Zone 1	<input checked="" type="checkbox"/>	37061234567	Geofence Zone 1
Geofence Zone 2	<input type="checkbox"/>	37061234567	Geofence Zone 2
Geofence Zone 3	<input type="checkbox"/>	37061234567	Geofence Zone 3
Geofence Zone 4	<input type="checkbox"/>	37061234567	Geofence Zone 4
Geofence Zone 5	<input type="checkbox"/>	37061234567	Geofence Zone 5

Figure 44 Geofence SMS event configuration

AutoGeofence

SMS events for AutoGeofence are configured the same as in Geofence. AutoGeofence is in Features -> Auto geofencing (Figure 45), for SMS events configuration, go to GSM -> SMS -> SMS Events (Figure 46).

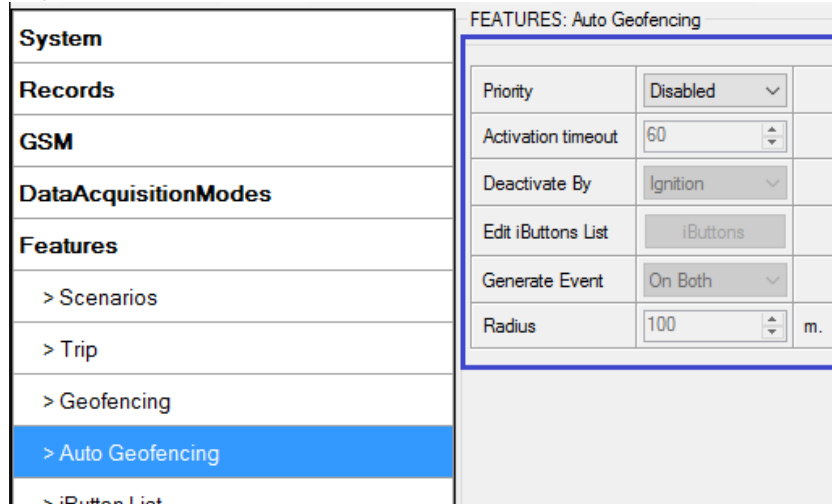

Figure 45 AutoGeofence configuration

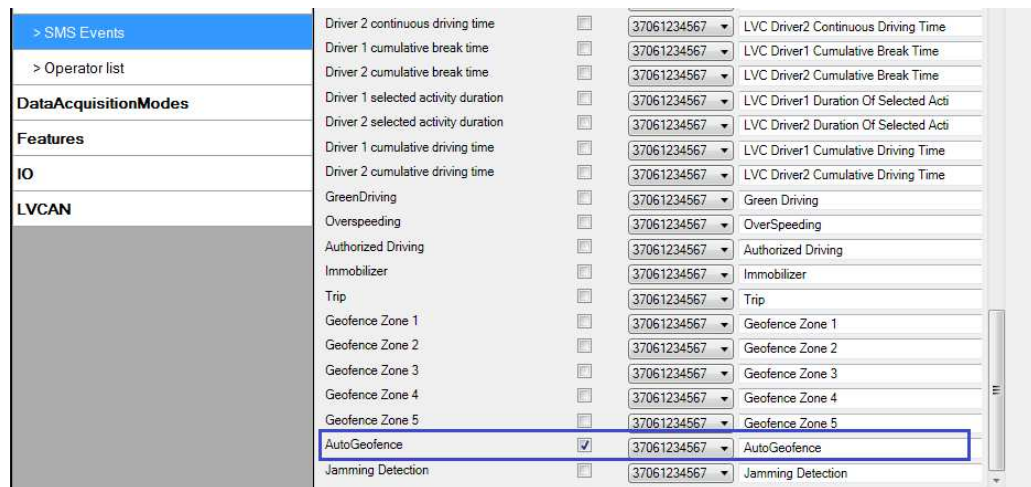

Figure 46 AutoGeofence SMS event configuration

I/O events

FM3600 sends SMS event message when a configured I/O property enters and/or exits its configured High/Low boundaries or Hysteresis event generation is chosen (Monitoring does not generate event, so SMS event could not be configured). Every IO element SMS event can be configured to send individual message to different numbers.

System	I/O						
Records	Property Input	<input type="checkbox"/> Enabled	Priority	Low Level	High Level	Generate Event	Averaging Constant
GSM	Digital input 1	<input checked="" type="checkbox"/>	High	0	1	On Both	10
DataAcquisitionModes	Digital input 2	<input type="checkbox"/>	Disabl	0	0	Monitoring	2
Features	Analog input 1	<input type="checkbox"/>	Disabl	0	0	Monitoring	2
IO	Digital output 1	<input type="checkbox"/>	Disabl	0	0	Monitoring	10
	Digital output 2	<input type="checkbox"/>	Disabl	0	0	Monitoring	10
	GNSS PDOP	<input type="checkbox"/>	Disabl	0	0	Monitoring	10
	GNSS HDOP	<input type="checkbox"/>	Disabl	0	0	Monitoring	10

Figure 47 I/O event configuration

System	SMS Events			
Records	Description	Enable	SMS Number	SMS Text
GSM	Digital input 1	<input checked="" type="checkbox"/>	37061234567	Digital Input 1
> GPRS	Digital input 2	<input type="checkbox"/>	37061234567	Digital Input 2
> SMS	Analog input 1	<input type="checkbox"/>	37061234567	Analog Input 1
> SMS Events	Digital output 1	<input type="checkbox"/>	37061234567	Digital Output 1
	Digital output 2	<input type="checkbox"/>	37061234567	Digital Output 2
	GNSS PDOP	<input type="checkbox"/>	37061234567	GNSS PDOP
	GNSS HDOP	<input type="checkbox"/>	37061234567	GNSS HDOP
	External voltage	<input type="checkbox"/>	37061234567	External Voltage

Figure 48 I/O SMS event configuration

5.15 I/O settings

When no I/O element is enabled, AVL packet comes with GNSS information only. After enabling I/O element(s) AVL packet along with GNSS information contains current value(s) of enabled I/O element.

Permanent I/O elements (are always sent to server if enabled)		
Nr.	Property Name	Description
0	Digital Input Status 1	Logic: 0 / 1
1	Digital Input Status 2	Logic: 0 / 1
2	Analog Input 1	Voltage: mV, 0 – 30 V
3	Digital Output 1	Logic: 0 / 1
4	Digital Output 2	Logic: 0 / 1
5	GNSS PDOP	Probability * 10; 0-500
6	GNSS HDOP	Probability * 10; 0-500
7	External Voltage	Voltage: mV, 0 – 30 V
8	GNSS Power	States: 0 – short circ., 1 – connected. Parameter defines if GNSS antenna is short circuit. All the time value will be sent 1. The only condition to get value 0, then antenna is damaged and short circuit. Note if you disconnect GNSS antenna it still will be sent 1. Do not try to use this parameter to see if antenna is disconnected.
9	Movement Sensor	0 – not moving, 1 – moving.
10	Odometer Value	Distance between two records: m
11	GSM Operator	Currently used GSM Operator code

12	Speed (Km/h)	Value in km/h, 0 – xxx km/h
13	iButton ID	iButton ID number
14	Mode	0 – home on stop, 1 – home on move, 2 – roaming on stop, 3 – roaming on move, 4 – unknown on stop, 5 – unknown on move
15	GSM Signal	GSM signal level value in scale 1 – 5
16	Deep Sleep	0 – not deep sleep mode, 1 – deep sleep mode
17	Cell ID	GSM base station ID
18	Area Code	Location Area code (LAC), it depends on GSM operator. It provides unique number which assigned to a set of base GSM stations. Max value: 65536
19	Dallas Temperature 1	10 * Degrees (°C), -55 - +115, if 3000 – Dallas error
20	Dallas Temperature 2	10 * Degrees (°C), -55 - +115, if 3000 – Dallas error
21	Dallas Temperature 3	10 * Degrees (°C), -55 - +115, if 3000 – Dallas error
22	Battery Voltage	Voltage: mV
23	Battery Charging Current	Current: mA
24	Ignition	Ignition status indication. Logic: 0 / 1
25	Network Type	0 – 3G network, 1 – 2G network
Eventual I/O elements (generate and send record to server only if appropriate conditions are met)		
Nr.	Property Name	Description
26	Geofence zone 01	Event: 0 – target left zone, 1 – target entered zone
27	Geofence zone 02	Event: 0 – target left zone, 1 – target entered zone
28	Geofence zone 03	Event: 0 – target left zone, 1 – target entered zone
29	Geofence zone 04	Event: 0 – target left zone, 1 – target entered zone
30	Geofence zone 05	Event: 0 – target left zone, 1 – target entered zone
31	Auto Geofence	Event: 0 – target left zone, 1 – target entered zone
32	Trip	1 – trip start, 0 – trip stop
33	Immobilizer	1 – iButton connected
34	Authorized driving	1 – authorized iButton connected
35	Green driving type	1 – harsh acceleration, 2 – harsh braking, 3 – harsh cornering
36	Green driving value	Depending on green driving type: if harsh acceleration or braking – g*100 (value 123 -> 1.23g), if harsh cornering – degrees (value in radians)
37	Over Speeding	At over speeding start km/h, at over speeding end km/h
38	LVCAN Speed	Value in km/h, 0 – 250 km/h
39	LVCAN Accelerator pedal position	Value range: 0-100 %

40	LVCAN Total fuel used	Value range: 0- 99999999 liters* „Total Fuel Used“ is sent to server multiplied by 10. Example: if value was 150.5 liters, „1505“ will be sent to server.
41	LVCAN Fuel level (liters)	Value range: 0-100 liters
42	LVCAN Engine RPM	Value range: 0-8200 rpm
43	LVCAN Vehicle distance	Value range: 0-2145000000 meters
44	LVCAN Fuel level (proc.)	Value range: 0-100 %
45	LVCAN Program number	Value range: 0-999



There are two types of operations with Permanent I/O elements: simple monitoring and event generating. Monitoring method is used when current I/O information needed with regular GNSS coordinates. Event generating method is used when additional AVL packet is needed when current value of I/O exceeds predefined High and Low levels. I/O settings allow defining I/O event criteria.

System	I/O						
Records	Property Input	<input type="checkbox"/> Enabled	Priority	Low Level	High Level	Generate Event	Averaging Constant
GSM	GNSS PDOP	<input type="checkbox"/>	Disable	0	0	Monitoring	10
	GNSS HDOP	<input type="checkbox"/>	Disable	0	0	Monitoring	10
DataAcquisitionModes	External voltage	<input type="checkbox"/>	Disable	10000	30000	On Exit	10
Features	GNSS power	<input type="checkbox"/>	Disable	0	0	Monitoring	
IO	Movement sensor	<input type="checkbox"/>	Disable	0	0	Monitoring	10
LVCAN	Odometer value	<input type="checkbox"/>	Disable	0	0	Monitoring	
	GSM operator	<input type="checkbox"/>	Disable	0	0	Monitoring	
	Speed (km/h)	<input type="checkbox"/>	Disable	0	0	Monitoring	60
	iButton ID	<input type="checkbox"/>	Disable	0	5	On Entrance	10
	Mode	<input type="checkbox"/>	Disable	0	0	Monitoring	

Figure 49 I/O settings

Enabled or disabled field – allows enabling I/O element so it is added to the data packet and is sent to the server. By default all I/O element are disabled and FM3600 records only GNSS coordinates.

Priority (AVL packet priority) can be low, high or panic. Regular packets are sent as Low priority records. When low priority event is triggered, FM3600 makes additional record with indication that the reason for that was I/O element change. When High priority is selected, module makes additional record with high priority flag and sends event packet immediately to the server by GPRS. Panic priority triggers same actions as high priority, but if GPRS fails, it sends AVL packet using SMS mode if SMS is **enabled in SMS settings**.

High and Low levels – define I/O value range. If I/O value enters or exits this range, FM3600 generates event. “Generate event” parameter defines when to generate event – when value enters defined range, exits it or both.

Averaging constant – it is an I/O event delay parameter. In some applications there is no need to generate events on every I/O range enter/exit immediately. Sometimes it is necessary to wait some time interval before event generating. Averaging constant allows setting I/O event delay (averaging). If I/O value is entering or leaving predefined range, it must have same value for Averaging constant time. 1 Averaging constant value equals about 30 milliseconds. In Deep Sleep mode there is no Averaging.



Note: I/O element's "Movement sensor" Averaging constant is interpreted as Start Move Timeout in seconds (from 1 to 59).
Start Move Timeout – is a time interval required for movement sensor to be in the moving state, to consider vehicle as moving.

5.15.1

Monitoring

I/O monitoring starts after enabling I/O element and setting up I/O parameters as it is shown below:

System	I/O	Property Input	Enabled	Priority	Low Level	High Level	Generate Event	Averaging Constant
Records	Digital input 1	<input checked="" type="checkbox"/>	Low	0	1	Monitoring	10	
GSM	Digital input 2	<input type="checkbox"/>	Disable	0	0	Monitoring	2	
DataAcquisitionModes	Analog input 1	<input type="checkbox"/>	Disable	0	0	Monitoring	2	
Features	Digital output 1	<input type="checkbox"/>	Disable	0	0	Monitoring	10	
I/O	Digital output 2	<input type="checkbox"/>	Disable	0	0	Monitoring	10	
LVCAN	GNSS PDOP	<input type="checkbox"/>	Disable	0	0	Monitoring	10	
	GNSS HDOP	<input type="checkbox"/>	Disable	0	0	Monitoring	10	
	External voltage	<input type="checkbox"/>	Disable	10000	30000	On Exit	10	

Figure 50 I/O settings

5.15.2 Event Generating

Events happen when the value of enabled I/O intersects thresholds (enter, exit or on both) predefined by High and Low level thresholds. Table below defines all available values of I/O settings.

Setting	Value
Priority	low, high
High level	maximum threshold
Low level	minimum threshold
Generate event	on interval enter, on interval exit, on both enter and exit
Average constant	$1 - 2^{32}$ (4 Bytes)

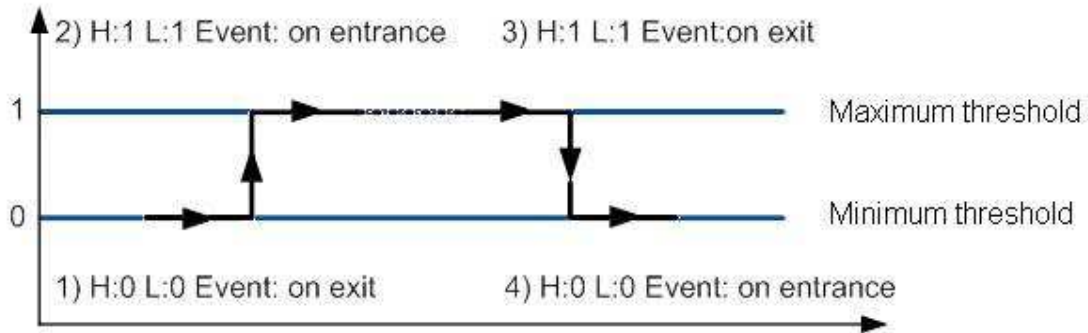

Figure 51 Digital Input event generation example

5.15.3 Hysteresis

Enabled	Priority	Low Level	High Level	Generate Event	Averaging Constant
<input checked="" type="checkbox"/>	Low	0	0	Hysteresis	10

Figure 52 Hysteresis parameter configuration

I/O elements can generate events according to hysteresis algorithm. If I/O event operand “Hysteresis” is selected, events will be generated as it is shown in the illustration below (I/O speed is taken as I/O value example):

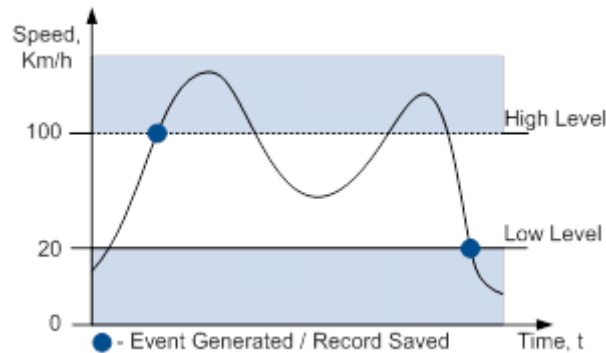

Figure 53 Event generation according hysteresis algorithm

6 SMS COMMAND LIST

Read chapter 5.11 to know how to construct a proper SMS message and send it to FM3600 device. All commands are case sensitive. While FM3600 operates in Deep Sleep mode and user tries to send SMS message it cannot arrive to FM3600 device, because GSM/GPRS module is disabled most of the time (wake up depends on Send Period parameter). FM3600 will receive the SMS when it wakes up (exits deep sleep mode).

6.1 SMS command list

Command	Description	Response
getstatus	Modem Status information	Yes
getweektime	Current device time, Day of Week and amount of minutes passed since start of week	Yes
getops	List of currently available GSM operator	Yes
getcfgtime	Date and Time of last successful configuration	Yes
ggps	Google Map Link information	Yes
getgps	Current GPS data and time	Yes
cpureset	Reset CPU	No
resetprof	Reset all FLASH1 profile configuration to default profile	No
getver	Device / Modem / Code version information	Yes
getinfo	Device runtime system information	Yes
deleterecords	Delete all records saved on FLASH	No
getio	Readout digital inputs and outputs	Yes
radio #	Readout digital input value according entered ID, # - ID value	Yes
setdigout ## Y1 Y2	set digital outputs 0 – OFF, 1 – ON Y1 – timeout for DO1 Y2 – timeout for DO2	Yes
getparam #	Readout parameter value according entered ID.	Yes

	# - ID value.	
setparam # #	Set parameter value according entered ID and Value. 1.# - ID value. 2.# - New Parameter Value	Yes
getparam 1271 X	X values can be 1,2,3.	Yes
flush #,#,#,#,#,#	Initiates all data sending to specified target server 1.# - IMEI 2.# - APN 3.# - LOGIN 4.# - PASS 5.# - IP 6.# - PORT 7.# - MODE (0-TCP/1-UDP)	No
readops #	1 – send first 20 operator codes, 2 – send from 21 st to 40 th operator codes, 3 – send all other operator codes	
sn #	Static navigation, 1 – enable, 0 – disable	Yes
banlist	Banned operators information	Yes
crashlog	Device last information before unexpected reset	Yes
delete_all_sms	Deletes all SMS	No
lvcangetprog	CAN Program Number request by SMS	Yes
lvcansetprog #	Set LVCAN program number	Yes
lvcangetinfo	Get LV-CAN info by SMS	Yes

6.1.1 getstatus

Response details	Description
Data Link	Indicate module connection to server at the moment: 0 – Not connected, 1 – connected
GPRS	Indicate if GPRS is available at the moment
Phone	Voice Call status: 0 – ready, 1 – unavailable, 2 – unknown, 3 – ringing, 4 – call in progress, 5 – asleep
SIM	SIM Status: 0-ready, 1-pin, 2-puk, 3-pin2, 4-puk2
OP	Connected to GSM Operator: numerical id of operator
Signal	GSM Signal Quality [0-5]
NewSMS	Indicate if new message received
Roaming	0 – Home Network, 1 – roaming
SMSFull	SMS storage is full? 0 – ok, 1 – SMS storage full
LAC	GSM Tower Location Area Code
Cell ID	GSM Tower Cell ID Code

Example: Data Link: 0 GPRS: 1 Phone: 0 SIM: 0 OP: 24602 Signal: 5 NewSMS: 0 Roaming: 0 SMSFull: 0 LAC: 1 Cell ID: 864

6.1.2 getweektime

Response details	Description
Clock Sync	Indicates system clock synchronization status. 0 – System is not synchronized, 1 – System synchronized
DOW	Day Of Week – indicates current day of week starting from 1 – Monday, 2 – Tuesday, etc.

Time	Indicates current GMT time
WeekTime	Indicates time in minutes starting from Monday 00:00 GMT

Example: Clock Sync: 1 DOW: 4 Time 12:58 Weektime: 6538

6.1.3 getops

Response details	Description
LIST	Returns list of current available allowed operators.

Example: (2,"LT BITE GSM","BITE","24602"),(3,"TELE2","TELE2","24603")

6.1.4 getcfgtime

Response details	Description
Date/Time	Returns last performed configuration date and time.

Example: Last Configuration was performed on: 2010.4.15 5:45:19

6.1.5 getgps

Response details	Description
Gps	Indicates valid (1) or invalid (0) Gps data
Sat	Count of currently available satellites
Lat	Latitude (Last good Latitude)
Long	Longitude (Last good Longitude)
Alt	Altitude
Speed	Ground speed, km/h
Dir	Ground direction, degrees
Date	Current date
Time	Current GMT time

Example: GPS:1 Sat:7 Lat:54.71473 Long:25.30304 Alt:147 Speed:0 Dir:77 Date: 2007/8/24
Time: 13:4:36

6.1.6 ggps

Response details	Description
D	Date
T	Time
S	Actual Speed
C	Latitude (Last good Latitude), Longitude (Last good Longitude)
Url	Google Maps Link

Example: D:2013/7/4 T:0:0:0 S:0 C:0, 0 Url: <http://maps.google.com/?q=0,0&om=1speed:0>

6.1.7 getver

Response details	Description
Code Ver	Firmware version
Device IMEI	IMEI
Device ID	Device ID is used to detect by server which type of configuration to load
Bootloader Ver	Bootloader Version
Modem App Ver	Version of modem application (veiks: nuo 00.05.14)

Revision	Firmware revision
----------	-------------------

Example: Code Ver:01.06.15 Rev:1 Device IMEI:353976010139156 Device ID:000001
 Bootloader Ver: 01.09 Modem APP Ver:TM11Q_R_01.00.03.03_002

6.1.8 getinfo

Response details	Description
INI	Device Initialization Time
RTC	RTC Time
RST	Restart Counter
ERR	Error Counter
SR	Number of Sent Records
BR	Number of broken records
CF	Profile CRC Fail counter
FG	Failed GPRS counter
FL	Failed link counter
UT	UPD Timeout counter
SMS	Sent SMS Counter
NOGPS	No GPS Timer
GPS	GPS receiver state. 0 – OFF, 1 – restarting, 2 – ON but no fix, 3 – ON and operational, 4 – sleep mode
SAT	Average satellites
RS	Reset Source Identification 1 – Low Power, 2 – W Watchdog, 3 – I Watchdog, 4 – Software reset, 5 – Power On, 6 – Pin Reset
MD	Data Mode state. 0 – Home and Stop, 1 – Home and Moving, 2 – Roaming and Stop, 3 – Roaming and Moving, 4 – Unknown and Stop, 5 – Unknown and Moving
RF	Records Found – number of records in the memory.

Example: INI:2013/10/11 8:44 RTC:2013/10/11 8:59 RST:1 ERR:0 SR:0 BR:0 CF:0 FG:0 FL:0
 UT:0 SMS:1 NOGPS:0:14 GPS:2 SAT:0 RS:3 MD:4 RF:0

6.1.9 getio

Response details	Description
DI#	Digital Input state
AIN#	Analog Input state
DO#	Digital Output state

Example: DI1:0 DI2:0 DI3:0 AIN:0.0611 DO1:0 DO2:0

6.1.10 readio

Response details	Description
ID	I/O element ID
Value	I/O Element value

Example: I/O ID:3 Value:0

6.1.11 setdigout ## Y1 Y2

Sets digital outputs to ON or OFF state (for some time if needed). Value is written as a row for OUT1 and OUT2 values.

Example: 'setdigout 01 0 5' will set OUT2 to high level for 5 seconds, while OUT1 to low level.

To ignore one digital output value and make ON/OFF state only to another digital output in place of 0 or 1 values, "?" must be used. Example: 'setdigout ?1' will set OUT2 to high level for indefinite period of time while OUT1 remains as it was set before.

6.1.12 getparam

Read parameter value. ID consists of 3 or 4 digits. Detailed list of parameters and IDs can be found in chapter number 8 "Parameter List"

Example: 'getparam 1245' command will request server IP address.

6.1.13 setparam

Sets new value for parameter. ID consists of 3 or 4 digits. Detailed list of parameters and IDs can be found in chapter number 8 "Parameter List"

Example: 'setparam 1245 127.0.0.1' will change configured IP address.

6.1.13. getparam 1271 X/212 X

X values can be 1,2,3.

If X = 1, Operator codes from 0-19 are read from configuration and sent via SMS.

If X = 2, Operator codes from 20-39 are read from configuration and sent via SMS.

If X = 3, Operator codes from 40-49 are read from configuration and sent via SMS.

If X = any other, Operator codes from 0-19 are read from configuration and sent via SMS.

6.1.14. setparam 1271 X/212 X

If X is from 0 to 49, X means index of operator code which has to be configured. Up to 20 operator codes may be configured in 1 SMS. Example: *Setparam 1271 16 24602,24603,24605*, here 16th, 17th and 18th operator codes are set. Note! Other operator codes are left unchanged in the configuration.

6.1.15 readops

Send from device Operator List.

1 – send first 20 operator codes, 2 – send from 21st to 40th operator codes, 3 – send all other operator codes.

6.1.16 flush #,#,#,#,#,#

Initiates all data sending by GPRS to specified target server. Comma separated parameters go as numbered:

- 1.# - IMEI
- 2.# - APN
- 3.# - GPRS LOGIN
- 4.# - GPRS PASSWORD
- 5.# - IP
- 6.# - PORT
- 7.# - MODE (0-TCP/1-UDP)

Parameters are separated by comma (no spaces needed). In case you don't need to enter parameter (Login/Pass) – do not put space, simply put comma and write next parameter.

Example: opa opa flush 353976012555151,banga,,212.47.99.62,12050,0

Response details	Description
FLUSH SMS Accepted	FLUSH SMS Accepted
# records found on FLASH	Number of records found on FLASH
Minimum Records to Send: #	Number of minimum saved records to send
GPRS Enabled: #	State of the GPRS connection, 0 – disabled; 1 – enabled
Time Sync: #	Indicates time synchronization on the device, 0 – not synchronized; 1 – synchronized

Example: FLUSH SMS Accepted. 11 records found on FLASH. Minimum Records to Send: 1. GPRS Enabled: 1. Time Sync: 1.

6.1.17 sn

Enables or disables Static navigation. 1 – enable, 0 – disable.

6.1.18 banlist

Gives a list of all banned operators.

Example when no operators are banned: 0000.00s.0.000

6.1.19 crashlog

Gives the last information before the device has crashed for unexpected reasons. It is useful when the device acts unexpectedly or restarts for unexplained reasons.

Example if no unexpected reset: “Crash: “

Example if unexpected reset was detected: “Crash: 3051,3052,3053”.

6.1.20 lvcانgetprog

CAN program number can be obtained via SMS:

SMS Text: “lvcانgetprog”

Response: “CAN Program Nr: XXXX”

6.1.21 lvcانsetprog

Set LV-CAN program number via SMS:

SMS Text: “lvcانsetprog 139”

Response: “CAN program Nr:139”

6.1.22 lvcانgetinfo

Get LV-CAN info by SMS

Full LV-CAN information via SMS:

SMS Text: “ lvcانgetinfo”

Response: “

Prog: 139

SWRevison: 6

KernVer: 10

KernVar: 49

MdlID: 8884443332221110”

7 Debug mode

FM3600 is able to transmit its current state when connected to PC using USB cable. It is used to detect errors and provide information to possible solutions when operating as unexpected. Download Terminal from:

<http://avl1.teltonika.lt/Downloads/Software/Terminal.zip>.

After launching terminal choose baud rate 115200 and hardware control – none. Select COM port which is assigned to “Virtual COM Port”. Click on ‘Start Log’ button and save a new file. Then click ‘Connect’ to start receiving messages from FM3600.

Also you can log NMEA data directly. To get NMEA data, simply enter the following command into the command field: **.log_nmea:1\$0a**.

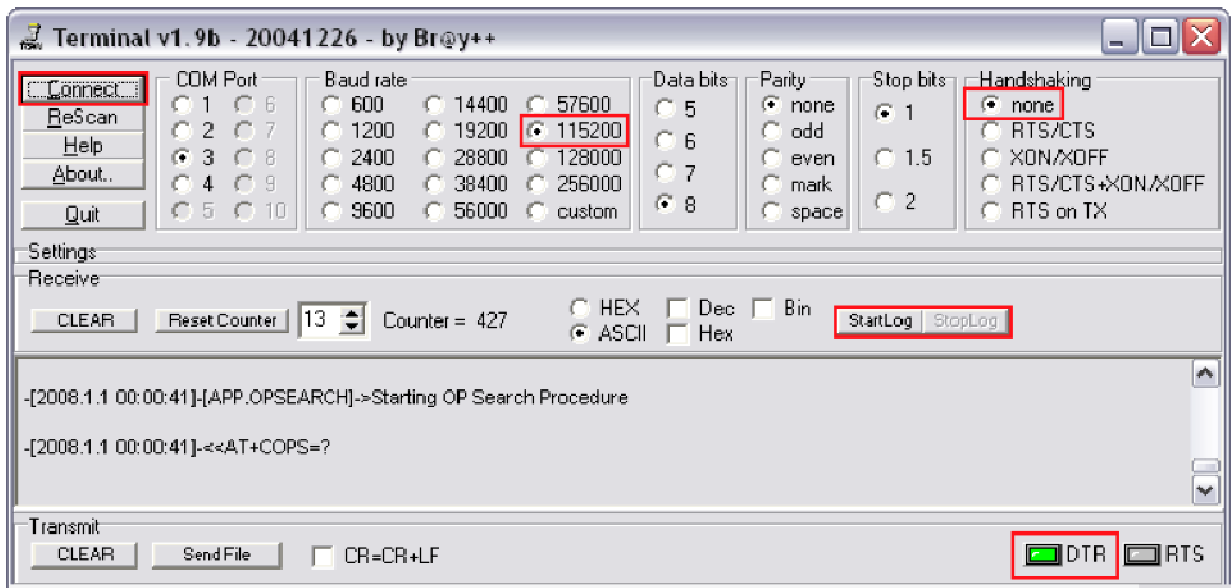

Figure 54 Terminal window for logging

8 Parameter List

8.1 Parameters value types

- S8 – Signed Char
- S8[n] – String of *n* Char
- U8 – Unsigned Char
- U16 – Unsigned Short
- S32 – Signed Integer
- U32 – Unsigned Integer
- U64 – Unsigned Long Long Integer

8.2 System parameters

8.2.1 Sleep Mode (ID=1000)

Device has two sleep modes: sleep and deep sleep mode. While sleep is disabled (value 0) module will never enter sleep mode, in sleep mode (value 1) module reduces level of power usage by turning GNSS module to sleep, in deep sleep mode (value 2) module turns GNSS

module to sleep and switch GSM module off (note, that FM3600 do not receive SMS while in deep sleep).

Minimum value	Maximum value	Recommended value	Goes with (depends on) parameters	Value type
0	2	-		U8

8.2.2 Sleep timeout (ID=200)

Sleep timeout is time after which FM3600 goes to sleep or deep sleep if other requirements are met. It is measured in minutes.

Minimum value	Maximum value	Recommended value	Goes with (depends on) parameters	Value type
1	3000	-		U8

8.2.3 Analog Input value range (ID=1001)

Analog input measuring resolution and range can be defined as 0...10V (value 0) or 1...30V (value 1).

Minimum value	Maximum value	Recommended value	Goes with (depends on) parameters	Value type
0	1	-		U8

8.2.4 Stop Detection Source (ID=1002)

Device can operate and change its working mode according to motion detection source: ignition (value 0), movement sensor (value 1), GPS (value 2).

Minimum value	Maximum value	Recommended value	Goes with (depends on) parameters	Value type
0	2	-		U8

8.2.5 Static Navigation (ID=1003)

When static navigation is enabled, FM3600 filters out GPS jumps, when it is not moving. When it is disabled, it does not make any changes to collected GPS data.

Minimum value	Maximum value	Recommended value	Goes with (depends on) parameters	Value type
0	1	1		U8

8.2.6 Ignition Source (ID=1004)

Ignition Source sets ignition triggered functionalities.

Parameter	ID	Value
Ignition Source	1004	0 (By Power Voltage – default)
		1 (By Ignition Din1)
		2 (By Movement sensor)
High Voltage Level*	1005	Min: 0, Max: 30000 (mV)
Low Voltage Level*	1006	Min: 0, Max: 30000 (mV)

* - used when External voltage selected as ignition source.

8.2.7 GNSS FIX Timeout for Time Synchronization via NTP (ID=1007)

If “GNSS FIX Timeout” is set too 60s (default value) and during this time GPS FIX is received – use default (GNSS) time synchronization method. However if the GPS time FIX is not received:

a. FM is going to get time using NTP server. Device will activate GPRS context and create UDP connection to destination port 123 using SNTP protocol.

Minimum value	Maximum value	Recommended value	Goes with (depends on) parameters	Value type
0	65535	60		U8

8.2.8 Saving/Sending without time synchronization (ID=201)

When this feature is enabled (value = 1), then records can be saved and sent to server without time synchronization.

Minimum value	Maximum value	Recommended value	Goes with (depends on) parameters	Value type
0	1	1		U8

8.2.9 GNSS System (ID=202)

This parameter sets Satellite System, available values: 0 – GNSS (all available); 1 – GPS only; 2 – GLONASS only.

Minimum value	Maximum value	Recommended value	Goes with (depends on) parameters	Value type
0	2	0		U8

8.3 Records parameters

8.3.1 Sorting (ID=1010)

Record sorting parameter is responsible for record sorting order. Value of 0 arranging data starting from newest, while value of 1 arranging data starting from oldest.

Minimum value	Maximum value	Recommended value	Goes with (depends on) parameters	Value type
0	1	-		U8

8.3.2 Active Data Link Timeout (ID=1011)

Defines for how many seconds device will keep connection to the server after successful data transfer while waiting for a new record.

Minimum value	Maximum value	Recommended value	Goes with (depends on) parameters	Value type
0	259200	-		U32

8.3.3 Server Response Timeout (ID=1012)

Defines time period (in seconds) for server response to sent records.

Minimum value	Maximum value	Recommended value	Goes with (depends on) parameters	Value type
1	300	-		U8



ATTENTION! Some GSM operators may disconnect the device from an active data link if the device doesn't send any data for a very long time, even if active data link timeout is set to maximum value. The amount of time that an operator keeps the link open depends solely on the operator. For example, if active data link timeout is set to maximum, 259200 seconds (72 hours), and the device sends data to server every 86400 seconds (24 hours), the operator might disconnect the link earlier and the device will have to connect to the server anew. This may cost extra, depending on the operator GPRS data charge. It is strongly recommended, when using active data link timeout, that data sending to the server should not be very rare (24 hours or more). If data sending is more frequent, then the operator will not disconnect the device from the server.

8.4 GSM parameters

8.4.1 GPRS content activation (ID=1240)

Parameter allows or does not allow GPRS usage. If GPRS is not allowed value is 0, if GPRS is allowed value is 1.

Minimum value	Maximum value	Recommended value	Goes with (depends on) parameters	Value type
0	1	-	APN Name (ID=1242) APN username (ID=1243) APN Password (ID=1244)	S8

8.4.2 APN Name (ID=1242)

Parameter defines GPRS Access Point Name.

Minimum value	Maximum value	Recommended value	Goes with (depends on) parameters	Value type
Empty	32 char string	-	GPRS content activation (ID=1240) APN username (ID=1243) APN Password (ID=1244)	S8[32]

8.4.3 APN username (ID=1243)

Parameter defines APN username. In case operator does not use username for login, value should be empty.

Minimum value	Maximum value	Recommended value	Goes with (depends on) parameters	Value type
Empty	30 char string	-	GPRS content activation (ID=1240) APN Name (ID=1242) APN Password (ID=1244)	S8[30]

8.4.4 APN Password (ID=1244)

Parameter defines APN password. In case operator does not use password for login, value should be empty.

Minimum value	Maximum value	Recommended value	Goes with (depends on) parameters	Value type
Empty	30 char string	-	GPRS content activation (ID=1240) APN Name (ID=1242) APN username (ID=1243)	S8[30]

8.4.5 Domain (ID=1245)

Parameter defines AVL data destination server IP address. Example: 212.47.99.62

Minimum value	Maximum value	Recommended value	Goes with (depends on) parameters	Value type
0	31 char string	-	GPRS content activation (ID=1240) Target Server Port (ID=1246)	S8[16]

8.4.6 Target Server Port (ID=1246)

Parameter defines AVL data destination server port number. Example: 12050

Minimum value	Maximum value	Recommended value	Goes with (depends on) parameters	Value type
Empty	65535	-	GPRS content activation (ID=1240) Domain (ID=1245)	U16

8.4.7 Protocol (ID=1247)

Parameter defines GPRS data transport protocol. Module can use TCP or UDP transport protocol to send data to server. For TCP protocol value is 0, for UDP protocol value is 1.

Minimum value	Maximum value	Recommended value	Goes with (depends on) parameters	Value type
0	1	-	GPRS content activation (ID=1240)	U8

8.4.8 Use 2G only (ID=1248)

User can choose if device will work only in GSM network, or it will prefer 3G network and switch to GSM only then 3G is absent. To work only with 2G network value is 1, to work with both networks value is 0.

Minimum value	Maximum value	Recommended value	Goes with (depends on) parameters	Value type
0	1	0	GPRS content activation (ID=1240)	U8

8.4.9 SMS Login (ID=1252)

User login is used to ensure module security. Used in every SMS that is sent to device. Example: ba321

Minimum value	Maximum value	Recommended value	Goes with (depends on) parameters	Value type
Empty	5 char	-	SMS Password (ID=1253)	S8[5]

8.4.10 SMS Password (ID=1253)

User password is used to ensure module security. Used in every SMS that is sent to device. Example: ab123

Minimum value	Maximum value	Recommended value	Goes with (depends on) parameters	Value type
Empty	5 char	-		S8[5]

8.4.11 SMS Time Zone (ID=1254)

Parameter allows to choose from all UTC Time lines for SMS data sending. This parameter unit is minutes and value increment/decrement step is 15 min. (0, 15, 30...).

Minimum value	Maximum value	Recommended value	Goes with (depends on) parameters	Value type
-720	+840	0	SMS Data send week time schedule (ID=1273)	U8

8.4.12 SMS data sending settings (ID=1250)

Parameter allows or does not allow sending AVL data using binary SMS. If SMS use is not allowed value is 0 and 1 if SMS use is allowed.

Minimum value	Maximum value	Recommended value	Goes with (depends on) parameters	Value type
0	1	-	SMS Data send week time schedule (ID=1273)	S8

8.4.13 SMS Data send week time schedule (ID=1273)

Parameter defines SMS data sending according to week time schedule. This parameter is used to set data sending on selected week days and hours. Minimum time step is 10 minutes.

Example value: 7F,FF,FF,FF,FF,FF,FF,FF,FF,FF,FF,FF,FF,FF,FF,FF,FF,FF

For more information read 8.5.1.4 "Schedule parameter format".

8.4.14 Authorized phone numbers (ID=1260-1270)

If at least one number is entered then only those number can send messages to device. Number must be entered without "+" or "00".

Example: 37060012346

Minimum value	Maximum value	Recommended value	Goes with (depends on) parameters	Value type
1 digit	16 digits	-		S8[17]

If SMS data sending is enabled (ID=1250) first value in a list is server GSM number. The SMS with 24 coordinates is sent to this number.

Deleting Authorized phone numbers: do not write any value in configuration SMS command.

Example: setparam 1260

8.4.15 SMS Event PreDefined Numbers (ID=150-159)

In this field are written GSM numbers, to which will be sent "Event SMS" text message. Number must be entered without "+" or "00".

Example: 37060012346

Minimum value	Maximum value	Recommended value	Goes with (depends on) parameters	Value type
1 digit	16 digits	-		S8[17]

8.4.16 Operator List (ID=1271 X)

Parameter defines operator list. According to this list module selects operating profile. GSM operator codes are comma separated. First in a list is *Home Operator Code*, then Preferred Roaming Operator Codes are written.

X defines starting position that is changed: If X is from 0 to 49, X means index of operator code which has to be configured. Up to 20 operator codes may be configured in 1 SMS. Example: `setparam 1271 16 24602,24603,24605`

Here 16th, 17th and 18th operator codes are set. Note! Other operator codes are left unchanged in the configuration.

Minimum value	Maximum value	Recommended value	Goes with (depends on) parameters	Value type
Empty	7 digits	-		U32

8.5 Data Acquisition Modes parameters

8.5.1 Home Network GSM operator code “Vehicle on STOP” parameters

8.5.1.1 Min Period (ID=1540)

This parameter indicates time interval in seconds in order to acquire new record. If value is 0 it means no records by min period will be saved.

Minimum value	Maximum value	Recommended value	Goes with (depends on) parameters	Value type
0	2592000	-		U32

8.5.1.2 Min Saved Records (ID=1543)

This parameter defines minimum number of records in one data packet that can be sent to server. It has higher priority than Data Send Period (ID=1544).

Minimum value	Maximum value	Recommended value	Goes with (depends on) parameters	Value type
1	255	1	GPRS Week Time (ID=1545)	U8

8.5.1.3 Send Period (ID=1544)

This parameter indicates frequency (time interval in seconds) of sending data to server.

Minimum value	Maximum value	Recommended value	Goes with (depends on) parameters	Value type
0	2592000	-	Min Saved Records (ID=1543) GPRS Week Time (ID=1545)	U32

8.5.1.4 GPRS Week Time (ID=1545)

This parameter manages when it is allowed to open GPRS context. When module starts it is prohibited to open the context. When modem’s GPRS context is closing (for example changing network) it is allowed to open it only at a defined time. It is possible to allow connections every 10 minutes up to once per day.

Example value: 7F,FF,FF,FF,FF,FF,FF,FF,FF,FF,FF,FF,FF,FF,FF,FF,FF,FF,FF,FF

Schedule parameter format:

Time is defined as 19 byte array (‘getparam’ 1545 returns 20 bytes). First byte of array defines week days; the rest 18 bytes define timestamps with 10 minute interval. In first byte, first bit (LSB) defines if module should connect to GPRS (send SMS) on Monday, second bit – on Tuesday and so on up to seventh bit – which means Sunday. Eighth bit (MSB) is not used. If bits value is 0 then device is not allowed to open GPRS context, but if it is already open – does not close it. If value is 1 it will work as day minutes are defined in rest of the bytes. Day’s minutes are defined by 18 bytes (144 bits). Every nth bit (beginning from the first bit (LSB) and ending 18 bytes 8th bit (MSB)) indicates every 10th minute of the day (day has 1440 minutes).

Sample: GPRS will be allowed on Monday to Friday at 8:00 and 16:00 GMT. The following value should be configured:

00011111 00000000 00000000 00000000 00000000 00000000 00000000 00000001 00000000 00000000
00000000 00000000 00000000 00000001 00000000 00000000 00000000 00000000 00000000

Red bits indicate that GPRS will be allowed every day except Saturdays and Sundays. Blue bits indicate 480 and 720 minutes (480min = 8h and 720min = 16h). So the parameter value should be: 1F,00,00,00,00,00,00,00,01,00,00,00,00,00,01,00,00,00,00,00

It should be sent as UTF8 encoded string.

8.5.2 Home Network GSM operator code "Vehicle MOVING" parameters

8.5.2.1 Min Period (ID=1550)

This parameter indicates time interval in seconds in order to acquire new record. If value is 0 it means no records by min period will be saved.

Minimum value	Maximum value	Recommended value	Goes with (depends on) parameters	Value type
0	2592000	-	Min Distance (ID=1551) Min Angle (ID=1552) Min Speed (ID=1556) GPRS Week Time (ID=1555)	U32

8.5.2.2 Min Distance (ID=1551)

This parameter indicates distance in meters in order to acquire new record. Record is stored when the distance between previous records is greater than parameters value. If value is 0 it means no records by min distance will be saved.

Minimum value	Maximum value	Recommended value	Goes with (depends on) parameters	Value type
0	65535	-	Min Period (ID=1550) Min Angle (ID=1552) Min Speed (ID=1556) GPRS Week Time (ID=1555)	U32

8.5.2.3 Min Angle (ID=1552)

This parameter indicates angle in degrees in order to acquire new record. If angle difference between last recorded coordinate and current position is greater than defined value, new record is stored. This parameter is operational, when speed is higher than 10km/h. If value is 0 it means no records by min angle will be saved.

Minimum value	Maximum value	Recommended value	Goes with (depends on) parameters	Value type
0	180	-	Min Period (ID=1550) Min Distance (ID=1551) Min Speed (ID=1556) GPRS Week Time (ID=1555)	U16

8.5.2.4 Min Speed (ID=1556)

This parameter indicates speed difference in order to acquire new record. If speed difference between last recorded coordinate and current position is greater than defined value, new record is stored. If value is 0 it means no records by min distance will be saved.

Minimum value	Maximum value	Recommended value	Goes with (depends on) parameters	Value type
0	255	10	Min Period (ID=1550) Min Distance (ID=1551) Min Angle (ID=1552) Min Speed Source (ID=1557) GPRS Week Time (ID=1555)	U16

8.5.2.5 Min Speed Source (ID=1557)

This parameter defines Source for speed difference calculation: 0 – GPS, 1 – LVCAN

Minimum value	Maximum value	Recommended value	Goes with (depends on) parameters	Value type
0	1	0	Min Period (ID=1550) Min Distance (ID=1551) Min Angle (ID=1552) Min Speed (ID=1556) GPRS Week Time (ID=1555)	U8

8.5.2.6 Min Saved Records (ID=1553)

This parameter defines minimum number of records in one data packet that can be sent to server. It has higher priority than Data Send Period (ID=1554).

Minimum value	Maximum value	Recommended value	Goes with (depends on) parameters	Value type
1	255	1	Min Period (ID=1550) Min Distance (ID=1551) Min Angle (ID=1552) Min Speed (ID=1556) GPRS Week Time (ID=1555)	U8

8.5.2.7 Send Period (ID=1554)

This parameter indicates frequency (time interval in seconds) of sending data to server.

Minimum value	Maximum value	Recommended value	Goes with (depends on) parameters	Value type
0	2592000	-	GPRS Week Time (ID=1555)	U32

8.5.2.8 GPRS Week Time (ID=1555)

Read 8.5.1.4.

8.5.3 Roaming Network GSM operator code “Vehicle on STOP” parameters

8.5.3.1 Min Period (ID=1560)

This parameter indicates time interval in seconds in order to acquire new record. If value is 0 it means no records by min period will be saved.

Minimum value	Maximum value	Recommended value	Goes with (depends on) parameters	Value type
0	2592000	-		U32

8.5.3.2 Min Saved Records (ID=1563)

This parameter defines minimum number of records in one data packet that can be sent to server. It has higher priority than Data Send Period (ID=1564).

Minimum value	Maximum value	Recommended value	Goes with (depends on) parameters	Value type
1	255	1	GPRS Week Time (ID=1565)	U8

8.5.3.3 Send Period (ID=1564)

This parameter indicates frequency (time interval in seconds) of sending data to server.

Minimum value	Maximum value	Recommended value	Goes with (depends on) parameters	Value type
0	2592000	-	Min Saved Records (ID=1563)	U32

			GPRS Week Time (ID=1565)	
--	--	--	--------------------------	--

8.5.3.4 GPRS Week Time (ID=1565)

Read chapter 8.5.1.4.

8.5.4 Roaming Network GSM operator code “Vehicle MOVING” parameters

8.5.4.1 Min Period (ID=1570)

This parameter indicates time interval in seconds in order to acquire new record. If value is 0 it means no records by min period will be saved.

Minimum value	Maximum value	Recommended value	Goes with (depends on) parameters	Value type
0	2592000	-	Min Distance (ID=1571) Min Angle (ID=1572) Min Speed (ID=1576) GPRS Week Time (ID=1575)	U32

8.5.4.2 Min Distance (ID=1571)

This parameter indicates distance in meters in order to acquire new record. Record is stored when the distance between previous records is greater than parameter’s value. If value is 0 it means no records by min distance will be saved.

Minimum value	Maximum value	Recommended value	Goes with (depends on) parameters	Value type
0	65535	-	Min Period (ID=1570) Min Angle (ID=1572) Min Speed (ID=1576) GPRS Week Time (ID=1575)	U32

8.5.4.3 Min Angle (ID=1572)

This parameter indicates angle in degrees in order to acquire new record. If angle difference between last recorded coordinate and current position is greater than defined value, new record is stored. This parameter is operational, when speed is higher than 10km/h. If value is 0 it means no records by min angle will be saved.

Minimum value	Maximum value	Recommended value	Goes with (depends on) parameters	Value type
0	180	-	Min Period (ID=1570) Min Angle (ID=1572) Min Speed (ID=1576) GPRS Week Time (ID=1575)	U16

8.5.4.4 Min Speed (ID=1576)

This parameter indicates speed difference in order to acquire new record. If speed difference between last recorded coordinate and current position is greater than defined value, new record is stored. If value is 0 it means no records by min distance will be saved.

Minimum value	Maximum value	Recommended value	Goes with (depends on) parameters	Value type

0	255	10	Min Period (ID=1570) Min Distance (ID=1571) Min Angle (ID=1572) Min Speed Source (ID=1577) GPRS Week Time (ID=1575)	U16
---	-----	----	--	-----

8.5.4.5 Min Speed Source (ID=1577)

This parameter defines Source for speed difference calculation: 0 – GPS, 1 – LVCAN

Minimum value	Maximum value	Recommended value	Goes with (depends on) parameters	Value type
0	1	0	Min Period (ID=1570) Min Distance (ID=1571) Min Angle (ID=1572) Min Speed (ID=1576) GPRS Week Time (ID=1575)	U8

8.5.4.6 Min Saved Records (ID=1573)

This parameter defines minimum number of records in one data packet that can be sent to server. It has higher priority than Data Send Period (ID=1574).

Minimum value	Maximum value	Recommended value	Goes with (depends on) parameters	Value type
1	255	1	Min Period (ID=1570) Min Distance (ID=1571) Min Angle (ID=1572) Min Speed (ID=1576) GPRS Week Time (ID=1575)	U8

8.5.4.7 Send Period (ID=1574)

This parameter indicates frequency (time interval in seconds) of sending data to server.

Minimum value	Maximum value	Recommended value	Goes with (depends on) parameters	Value type
0	2592000	-	Min Saved Records (ID=1573) GPRS Week Time (ID=1575)	U32

8.5.4.8 GPRS Week Time (ID=1575)

Read chapter 8.5.1.4.

8.5.5 Unknown Network GSM operator code “Vehicle on STOP” parameters

8.5.5.1 Min Period (ID=1580)

This parameter indicates time interval in seconds in order to acquire new record. If value is 0 it means no records by min period will be saved.

Minimum value	Maximum value	Recommended value	Goes with (depends on) parameters	Value type
0	2592000	-		U32

8.5.5.2 Min Saved Records (ID=1583)

This parameter defines minimum number of records in one data packet that can be sent to server. It has higher priority than Data Send Period (ID=1584).

Minimum value	Maximum value	Recommended value	Goes with (depends on) parameters	Value type
1	255	1	GPRS Week Time (ID=1585)	U8

8.5.5.3 Send Period (ID=1584)

This parameter indicates frequency (time interval in seconds) of sending data to server.

Minimum value	Maximum value	Recommended value	Goes with (depends on) parameters	Value type
0	2592000	-	Min Saved Records (ID=1583) GPRS Week Time (ID=1585)	U32

8.5.5.4 GPRS Week Time (ID=1585)

Read chapter 8.5.1.4.

8.5.6 Unknown Network GSM operator code "Vehicle MOVING" parameters

8.5.6.1 Min Period (ID=1590)

This parameter indicates time interval in seconds in order to acquire new record. If value is 0 it means no records by min period will be saved.

Minimum value	Maximum value	Recommended value	Goes with (depends on) parameters	Value type
0	2592000	-	Min Distance (ID=1591) Min Angle (ID=1592) Min Speed (ID=1596) Min Speed Source (ID=1597) GPRS Week Time (ID=1595)	U32

8.5.6.2 Min Distance (ID=1591)

This parameter indicates distance in meters in order to acquire new record. Record is stored when the distance between previous records is greater than parameter's value. If value is 0 it means no records by min distance will be saved.

Minimum value	Maximum value	Recommended value	Goes with (depends on) parameters	Value type
0	65535	-	Min Period (ID=1590) Min Angle (ID=1592) Min Speed (ID=1596) GPRS Week Time (ID=1595)	U32

8.5.6.3 Min Angle (ID=1592)

This parameter indicates angle in degrees in order to acquire new record. If angle difference between last recorded coordinate and current position is greater than defined value, new record is stored. This parameter is operational, when speed is higher than 10km/h. If value is 0 it means no records by min angle will be saved.

Minimum value	Maximum value	Recommended value	Goes with (depends on) parameters	Value type
0	180	-	Min Period (ID=1590) Min Distance (ID=1591) Min Speed (ID=1596)	U16

			GPRS Week Time (ID=1595)	
--	--	--	---------------------------------	--

8.5.6.4 Min Speed (ID=1596)

This parameter indicates speed difference in order to acquire new record. If speed difference between last recorded coordinate and current position is greater than defined value, new record is stored. If value is 0 it means no records by min distance will be saved.

Minimum value	Maximum value	Recommended value	Goes with (depends on) parameters	Value type
0	255	1	Min Period (ID=1590) Min Distance (ID=1591) Min Angle (ID=1592) Min Speed Source (ID=1597) GPRS Week Time (ID=1595)	U16

8.5.6.5 Min Speed Source (ID=1597)

This parameter defines Source for speed difference calculation: 0 – GPS, 1 – LVCAN

Minimum value	Maximum value	Recommended value	Goes with (depends on) parameters	Value type
0	1	0	Min Period (ID=1590) Min Distance (ID=1591) Min Angle (ID=1592) Min Speed (ID=1596) GPRS Week Time (ID=1595)	U8

8.5.6.6 Min Saved Records (ID=1593)

This parameter defines minimum number of records in one data packet that can be sent to server. It has higher priority than Data Send Period (ID=1594).

Minimum value	Maximum value	Recommended value	Goes with (depends on) parameters	Value type
1	255	1	Min Period (ID=1590) Min Distance (ID=1591) Min Angle (ID=1592) Min Speed (ID=1596) GPRS Week Time (ID=1595)	U8

8.5.6.7 Send Period (ID=1594)

This parameter indicates frequency (time interval in seconds) of sending data to server. In order to send data to server GPRS parameters must be enabled

Minimum value	Maximum value	Recommended value	Goes with (depends on) parameters	Value type
0	2592000	-	Min Saved Records (ID=1593) GPRS Week Time (ID=1595)	U32

8.5.6.8 GPRS Week Time (ID=1595)

Read chapter 8.5.1.4.

8.6 Features Parameters

8.6.1 Green Driving scenario (ID=1600)

Green driving scenario can be enabled to work with 3 different ways: Dout not control scenario (value 1), Dout1 controls scenario (value 2), Dout2 controls scenario (value 3). To disable green driving scenario value 0 is used.

Minimum value	Maximum value	Default value	Goes with (depends on) parameters	Value type
0	3	0		U8

8.6.2 Max Acceleration Force (ID=1602)

It is max allowed acceleration force which can be reached while accelerating without triggering harsh acceleration event.

Minimum value	Maximum value	Recommended value	Goes with (depends on) parameters	Value type
0.25	0.85	0.25	Green Driving scenario (ID=1600)	Float

8.6.3 Max Braking Force (ID=1603)

It is max allowed braking force which can be reached while braking without triggering harsh braking event.

Minimum value	Maximum value	Recommended value	Goes with (depends on) parameters	Value type
0.25	0.85	0.35	Green Driving scenario (ID=1600)	Float

8.6.4 Max Cornering Force (ID=1604)

It is max allowed cornering angle which can be reached while cornering without triggering harsh cornering event.

Minimum value	Maximum value	Recommended value	Goes with (depends on) parameters	Value type
0.1	1.0	-	Green Driving scenario (ID=1600)	U16

8.6.5 Max allowed Speed (ID=1605)

It is max allowed speed which can be reached. If this value exceeded Over speeding event will occur.

Minimum value	Maximum value	Recommended value	Goes with (depends on) parameters	Value type
0	260	-	Green Driving scenario (ID=1600)	U16

8.6.6 OverSpeeding scenario (ID=1601)

OverSpeeding scenario can be enabled to work with 3 different ways: Dout not control scenario (value 1), Dout1 controls scenario (value 2), Dout2 controls scenario (value 3). To disable OverSpeeding scenario value 0 is used.

Minimum value	Maximum value	Default value	Goes with (depends on) parameters	Value type
0	3	0		U8

8.6.7 Jamming detection scenario (ID=1606)

Jamming detection scenario can be enabled to work with 3 different ways: Dout not control scenario (value 1), Dout1 controls scenario (value 2), Dout2 controls scenario (value 3). To disable Jamming detection scenario value 0 is used.

Minimum value	Maximum value	Default value	Goes with (depends on) parameters	Value type
0	3	0		U8

8.6.8 Immobilizer scenario (ID=1607)

Immobilizer detection scenario can be enabled to work with 3 different ways: Dout not control scenario (value 1), Dout1 controls scenario (value 2), Dout2 controls scenario (value 3). To disable Immobilizer detection scenario value 0 is used.

Minimum value	Maximum value	Default value	Goes with (depends on) parameters	Value type
0	3	0		U8

8.6.9 iButton list checking scenario (ID=1608)

iButton list checking detection scenario can be enabled (value 1) or disabled (value 2).

Minimum value	Maximum value	Default value	Goes with (depends on) parameters	Value type
0	3	0		U8

8.6.10 Trip (ID=1280)

This parameter enables ability to detect START and STOP of the trip.

Minimum value	Maximum value	Recommended value	Goes with (depends on) parameters	Value type
0	1	-		U8

8.6.11 Start Speed (ID=1281)

This parameter represents speed, which is detected as minimum speed to indicate TRIP START and generate event.

Minimum value	Maximum value	Recommended value	Goes with (depends on) parameters	Value type
0	255	-	Trip(ID=1280)	U8

8.6.12 Ignition Off Timeout (ID=1282)

This parameter represents timeout to wait if ignition is off in order to detect TRIP STOP and generate event.

Minimum value	Maximum value	Recommended value	Goes with (depends on) parameters	Value type
0	65535	-	Trip(ID=1280)	U16

8.6.13 Trip Continuous distance counting (ID=1283)

For this feature I/O#10 ODOMETER must be enabled. If I/O ODOMETER is enabled, and Continuous distance counting variable is set to Continuous (value 1), TRIP distance is going to be counted continuously (from TRIP start to TRIP stop) and shown as I/O ODOMETER value.

Minimum value	Maximum value	Recommended value	Goes with (depends on) parameters	Value type
0	1	-	Trip(ID=1280) I/O#10- Odometer (ID=2100 - 2104)	U8

8.6.14 Geofencing

In this chapter it is explained how to get all parameters for the first Geofence zone (all ID numbers are for the 1st zone). And at the end of the chapter (part 8.6.10) is presented a table with the IDs of all the rest Geofence zones.

8.6.14.1 Frame border (ID=1020)

Geofence border thickness, measured in meters.

Minimum value	Maximum value	Recommended value	Goes with (depends on) parameters	Value type
0	1000000	1000	All Geofencing parameters	U32

8.6.14.2 Geofence Zone #1 Shape (ID=1030)

Geofence shape parameter can be: circle – value 0; rectangle – value 1.

Minimum value	Maximum value	Recommended value	Goes with (depends on) parameters	Value type
0	1	-	All Geofencing parameters	U8

8.6.14.3 Geofence Zone #1 Priority (ID=1031)

Parameter defines Geofence priority: 0 is Disabled 1 – low, 2 – high, 3 – panic;

Minimum value	Maximum value	Recommended value	Goes with (depends on) parameters	Value type
0	3	-	All Geofencing parameters	U8

8.6.14.4 Geofence Zone #1 Generate Event (ID=1032)

Generate event on:

- a) On exiting zone – value 0;
- b) On entering zone – value 1;
- c) On both – value 2;

Minimum value	Maximum value	Recommended value	Goes with (depends on) parameters	Value type
0	3	-	All Geofencing parameters	U8

8.6.14.5 Geofence Zone #1 Longitude (X1) (ID=1033)

Parameter has two meanings dependent on zone shape. If shape is a rectangle, then ID=1033 is left down corner X coordinate. If shape is a circle, then ID=1033 is center of that circle X coordinate.

Sample value: 25.30528

Minimum value	Maximum value	Recommended value	Goes with (depends on) parameters	Value type
-180	180	-	All Geofencing parameters	Float

8.6.14.6 Geofence Zone #1 Latitude (Y1) (ID=1034)

Parameter has two meanings dependent on zone shape. If shape is a rectangle, then ID=1034 is left down corner Y coordinate. If shape is a circle, then ID=1034 is center of that circle Y coordinate.

Minimum value	Maximum value	Recommended value	Goes with (depends on) parameters	Value type
-90	90	-	All Geofencing parameters	Float

8.6.14.7 Geofence Zone #1 Longitude (X2) (ID=1035)

Parameter has two meanings depending on zone shape. If shape is a rectangle, then ID=1035 is right upper corner X coordinate. If shape is a circle, then ID=1035 is radius of circle with center of ID=1033 and ID=1034.

For rectangle:

Minimum value	Maximum value	Recommended value	Goes with (depends on) parameters	Value type
-180	180	-	All Geofencing parameters	Float

For circle:

Minimum value	Maximum value	Recommended value	Goes with (depends on) parameters	Value type
0	1000000	1000	All Geofencing parameters	Float

8.6.14.8 Geofence Zone #1 Latitude (Y2) (ID=1036)

If shape is rectangular, then ID=1036 is right upper corner Y coordinate. If shape circle, ID=1036 is not used.

Minimum value	Maximum value	Recommended value	Goes with (depends on) parameters	Value type
-90	90	-	All Geofencing parameters	Float

Other 4 GeoFence zone's parameters have the same logic as shown in GeoFence Zone #1.

GeoFence Zone Number	Geofence Zone's parameters
1	1030-1036
2	1040-1046
3	1050-1056
4	1060-1066
5	1070-1076

8.6.15 AutoGeofencing

8.6.15.1 Activation Timeout (ID=1102)

Parameter represents AutoGeofencing activation timeout in seconds.

Minimum value	Maximum value	Recommended value	Goes with (depends on) parameters	Value type
0	65535	60	Priority (ID=1103)	U16

8.6.15.2 Deactivate by (ID=1100)

Parameter defines Autogeofence deactivation source. Value 1 is dedicated for attached iButton, value 0 – for Ignition.

Minimum value	Maximum value	Recommended value	Goes with (depends on) parameters	Value type
0	1	-	Priority (ID=1103) iButton List (ID=7000-7499)	U8

8.6.15.3 AutoGeofence event Priority (ID=1103)

Parameter defines AutoGeofence event priority: 0 is Disabled, 1 – low, 2 – high;

Minimum value	Maximum value	Recommended value	Goes with (depends on) parameters	Value type
0	2	1	AutoGeofence event generating (ID=1104)	U8

8.6.15.4 AutoGeofence event generating (ID=1104)

Generate event: 0 – on exiting zone; 1 – on entering zone; 2 – on both;

Minimum value	Maximum value	Recommended value	Goes with (depends on) parameters	Value type
0	2	0	Priority (ID=1103) AutoGeofence event Priority (ID=1103)	U8

8.6.15.5 Radius (ID=1105)

Parameter represents radius of circle with center device coordinates after activating AutoGeofence feature.

Minimum value	Maximum value	Recommended value	Goes with (depends on) parameters	Value type
0	1000000	100	Priority (ID=1103) Deactivate by (ID=1100)	U32

8.6.16 iButton List (ID=7000-7499)

Read 5.4.4.

Minimum value	Maximum value	Recommended value	Goes with (depends on) parameters	Value type
0	FFFFFFFF FFFFFFFF	-	iButtons list checking (ID 1608) Deactivate by (ID=1100)	U64

8.7 I/O parameters

I/O properties are additional data sources which are recorded along with usual GPS data.

8.7.1 I/O#1 Priority (ID=2000)

Parameter defines I/O property type of priority: 0 is Disabled, 1 – low, 2 – high, 3 – panic.

Minimum value	Maximum value	Recommended value	Goes with (depends on) parameters	Value type
0	3	1	I/O#1 event generation type (ID=2001) I/O#1 Low level (ID=2002) I/O#1 High level (ID=2003) I/O#1 averaging length (ID=2004)	S8

8.7.2 I/O#1 event generation type (ID=2001)

Parameter defines when event is sent: 0 – on range exit, 1 – on range entrance, 2 – both, 3 – monitoring, 4 – hysteresis, 5 – on changes.

Minimal value	Maximum value	Recommended value	Goes with (depends on) parameters	Value type
0	4	3	I/O#1 Priority (ID=2000) I/O#1 Low level (ID=2002) I/O#1 High level (ID=2003) I/O#1 averaging length (ID=2004)	S8

8.7.3 I/O#1 Low level (ID=2002)

Parameter defines low value of triggered I/O property. This parameter is used to set thresholds for I/O properties to generate events.

Minimum value	Maximum value	Recommended value	Goes with (depends on) parameters	Value type
-2147483647	2147483647	0	I/O#1 Priority (ID=2000) I/O#1 event generation type (ID=2001) I/O#1 High level (ID=2003) I/O#1 averaging length (ID=2004)	S32

8.7.4 I/O#1 High level (ID=2003)

Parameter defines high value of triggered I/O property. This parameter is used to set thresholds for I/O properties to generate events.

Minimum value	Maximum value	Recommended value	Goes with (depends on) parameters	Value type
-2147483647	2147483647	1	I/O#1 Priority (ID=2000) I/O#1 Low level (ID=2002) I/O#1 event generation type (ID=2001) I/O#1 averaging length (ID=2004)	S32

8.7.5 I/O#1 averaging length (ID=2004)

Parameter defines I/O property sample length to average. If no averaging needed default value is 1.

Minimum value	Maximum value	Recommended value	Goes with (depends on) parameters	Value type
0	2592000	1	I/O#1 High level (ID=2003) I/O#1 Low level (ID=2002) I/O#1 High level (ID=2003) I/O#1 event generation type (ID=2001)	S32

Other I/O property elements can be configured in same logic. All I/O element parameters are listed in the next table.

I/O Element Number	I/O element parameters
I/O#0 – Digital Input 1	2000 – 2004
I/O#1 – Digital Input 2	2010 – 2014
I/O#2 – Analog Input 1	2020 – 2024
I/O#3 – Digital Output 1	2030 – 2034
I/O#4 – Digital Output 2	2040 – 2044
I/O#5 – GNSS PDOP	2050 – 2054
I/O#6 – GNSS HDOP	2060 – 2064
I/O#7 – External Voltage	2070 – 2074
I/O#8 – GNSS Power	2080 – 2084
I/O#9 – Movement Sensor	2090 – 2094
I/O#10 – Odometer Value	2100 – 2104
I/O#11 – GSM Operator	2110 – 2114
I/O#12 – Speed (Km/h)	2120 – 2124
I/O#13 – iButton ID	2130 – 2134
I/O#14 – Mode	2140 – 2144
I/O#15 – GSM Signal	2150 – 2154
I/O#16 – Deep Sleep	2160 – 2164
I/O#17 – Cell ID	2170 – 2174
I/O#18 – Area Code	2180 – 2184
I/O#19 – Dallas Temperature 1	2190 – 2194
I/O#20 – Dallas Temperature 2	2200 – 2204
I/O#21 – Dallas Temperature 3	2210 – 2214
I/O#22 – Battery Voltage	2220 – 2224
I/O#23 – Battery Charging Current	2230 – 2234
I/O#24 – Ignition	2240 – 2244
I/O#25 – Network Type	2250 – 2254
I/O#26 – Reserved IO1	2260 – 2264
I/O#27 – Reserved IO2	2270 – 2274
I/O#28 – Reserved IO3	2280 – 2284

8.8 SMS event configuration

8.8.1 I/O#1 element SMS event configuration (ID=5100)

Command sets SMS warning on I/O#1 element.

SMS Format: setparam X Y,W,Z

X – ID

Y – Enable/Disable (1/0)

W – Telephone number INDEX (See **8.4.18 SMS Event Predefined Numbers** paragraph, ID 150 – INDEX 0; ID151 – INDEX 1, ...)

Z – SMS Text

Example: “setparam 5100 1,5,Digital Input 1 Event!”

Other I/O element SMS events can be configured in same logic. All I/O element SMS event IDs are listed in the next table.

Element name (default SMS Event Text)	ID
Digital input 1	5100
Digital input 2	5101
Analog Input 1	5102
Digital Output 1	5103
Digital Output 2	5104
GNSS PDOP	5105
GNSS HDOP	5106
External Voltage	5107
GNSS Power	5108
Movement Sensor	5109
Odometer Value	5110
GSM Operator	5111
Speed	5112
iButton ID	5113
Data Mode	5114
GSM Signal	5115
Deep Sleep	5116
Cell ID	5117
Area Code	5118
Dallas Temperature 1	5119
Dallas Temperature 2	5120
Dallas Temperature 3	5121
Battery Voltage	5122
Battery Current	5123
Ignition	5124
Network Type	5125
LVC Vehicle Speed	5129
LVC Accelerator Pedal Position	5130
LVC Fuel Consumed	5131

LVC Fuel Level (liters)	5132
LVC Engine RPM	5133
LVC Total Mileage	5134
LVC Fuel Level (percent)	5135
LVC Program Number	5136
LVC ModuleID	5137
LVC Engine Work Time	5138
LVC Engine Work Time (counted)	5139
LVC Total Mileage (counted)	5140
LVC Fuel Consumed (counted)	5141
LVC Fuel Rate	5142
LVC AdBlue Level (percent)	5143
LVC AdBlue Level (liters)	5144
LVC Engine Load	5145
LVC Engine Temperature	5146
LVC Axle 1 Load	5147
LVC Axle 2 Load	5148
LVC Axle 3 Load	5149
LVC Axle 4 Load	5150
LVC Axle 5 Load	5151
LVC Control State Flags	5152
LVC Agricultural Machinery Flags	5153
LVC Harvesting Time	5154
LVC Area of Harvest	5155
LVC Mowing Efficiency	5156
LVC Grain Mown Volume	5157
LVC Grain Moisture	5158
LVC Harvesting Drum RPM	5159
LVC Gap Under Harvesting Drum	5160
LVC Security State Flags	5161
LVC Tacho Total Vehicle Distance	5162
LVC Trip Distance	5163
LVC Tacho Vehicle Speed	5164
LVC Tacho Driver Card Presence	5165
LVC Driver1 States	5166
LVC Driver2 States	5167
LVC Driver1 Continuous Driving Time	5168
LVC Driver2 Continuous Driving Time	5169
LVC Driver1 Cumulative Break Time	5170
LVC Driver2 Cumulative Break Time	5171
LVC Driver1 Duration Of Selected Acti	5172
LVC Driver2 Duration Of Selected Acti	5173
LVC Driver1 Cumulative Driving Time	5174
LVC Driver2 Cumulative Driving Time	5175
Green Driving	5176

OverSpeeding	5178
Authorized Driving	5179
Immobilizer	5180
Trip	5181
Geofence Zone 1	5182
Geofence Zone 2	5183
Geofence Zone 3	5184
Geofence Zone 4	5185
Geofence Zone 5	5186
AutoGeofence	5187
Jamming Detection	5188

9 FM3600 with Light Vehicles Can adapter LV-CAN200

9.1 Purpose of Light Vehicles Can Adapter LV-CAN200

LV-CAN200 is used to listening data from light vehicles. With this adapter FM3600 device is able to collect and send vehicle data.

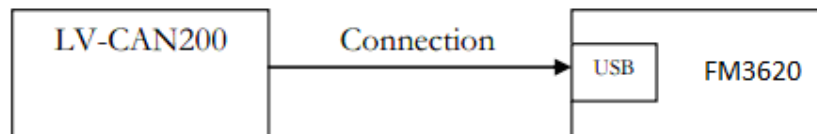

Figure 4 Connect adapter LV-CAN100 to FM3620

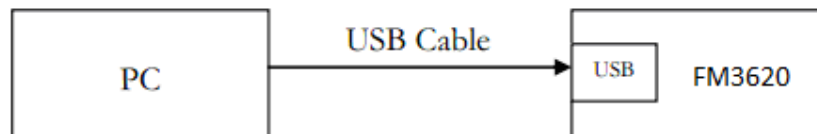

Figure 53 connection block diagram

FM3600 shares the same USB port for connecting adapter and configuring device with PC.

LV-CAN200 Technical characteristics:

PARAMETER	VALUE
Supply voltage	9 to 50V
Power supply current	Average 10mA Max (peak) 100mA
Working temperature	-40..85 °C
Max working humidity	60 % (non condensate)

9.2 LV-CAN200 program number selection

LV-CAN200 must be set to program number which depends on vehicle model. **Needed program number is always written on LV-CAN200 mounting scheme.** Please contact Your Teltonika sales manager to get latest supported vehicle list and mounting scheme for your vehicle, please provide CAR manufacturer, model and year information.

9.2.1 LV-CAN200 program number configuration via SMS command

LV-CAN200 program number can be set remotely, using SMS command:

lvcansetprog X

X is new program number value.

9.2.2 Selecting LV-CAN200 program number manually

Steps to set program number:

- Hold SWITCH down till LED starts blinking
- Release the SWITCH
- Then LED starts blinking and counting first digit of program number, (one blink means digit 1, two blink digit 2 etc.)
- To stop counter push SWITCH
- Release the SWITCH, then LED starts blinking and counting second digit of program number
- To stop counter push SWITCH
- Release the SWITCH, then LED starts blinking and counting third digit on program number
- To stop counter push SWITCH
- Release SWITCH, if programming is succeeded LED will blink 10 times



Figure 55 Adapter signaling led

9.2.3 Program number logic change

Due to the growing number of supported cars, program numbers have exceeded 999. In order to maintain one number format, we are moving from 3 digits, to 4 digits program numbers.

In new LV-CAN200/ALL-CAN300 firmware (from 2017-09-01) all program numbers that were up to 999 are changed to start from 1000. So that further program numbers would continue the counting with 4 digit numbers.

However, all existing program numbers stays the same, it is just "1" appeared in front of them. Device still understands entered 3 digit program number (via SMS/GPRS), it will automatically add "1" before it. If you enter "247" - device will turn it into the "1247". In Bootloader it is only 4 digit format available, just add "1" in front of the needed program number.

Example:

If use oldest connection schemes where program number displayed as 3 digit program number:

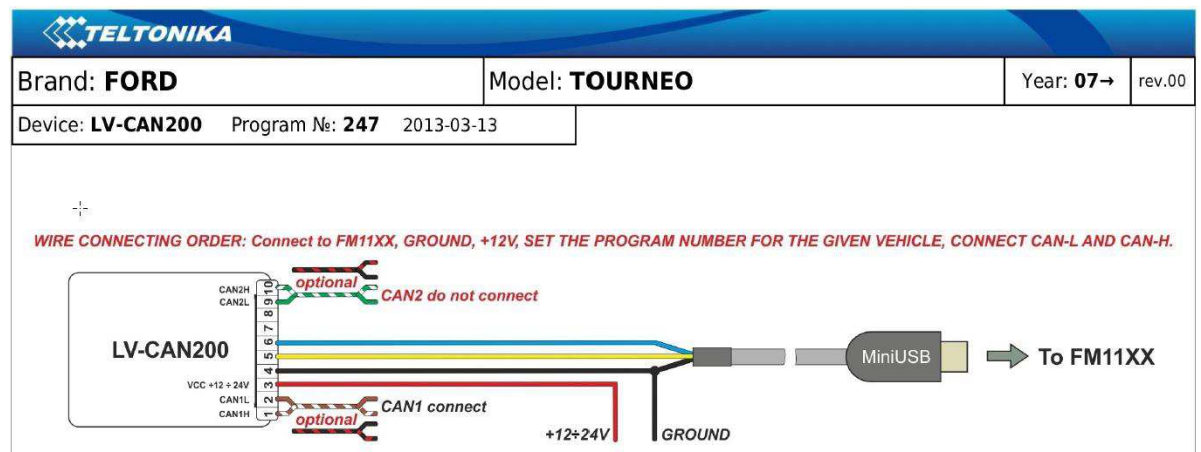

Using LV-CAN200/ALL-CAN300 Bootloader from soft version 2017-09-27 need add "1" before it:

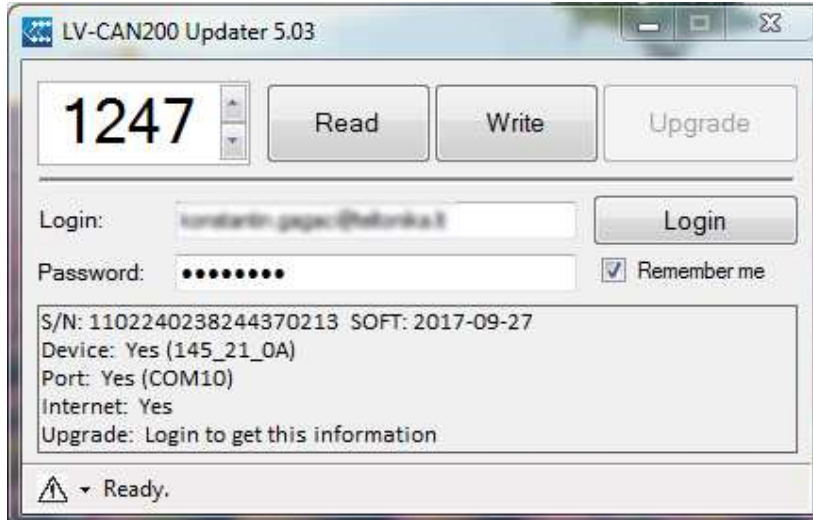

9.3 Connecting FM3600 with Light Vehicles Can adapter

Connect USB Plug to FM3600 device, connect Light Vehicles Can adapter to other end of the cable.

Connect Light Vehicles Can adapter Pin 1 and Pin 2 to cars CAN bus. CAN interface location of the supported light vehicle is described on mounting scheme.

Connect car power supply lines to Pin 3 positive, Pin 4 Negative.

Pins 9,10 connection is optional it depends on exact car model.

For exact pinout see sticker on Light Vehicles Can adapter.

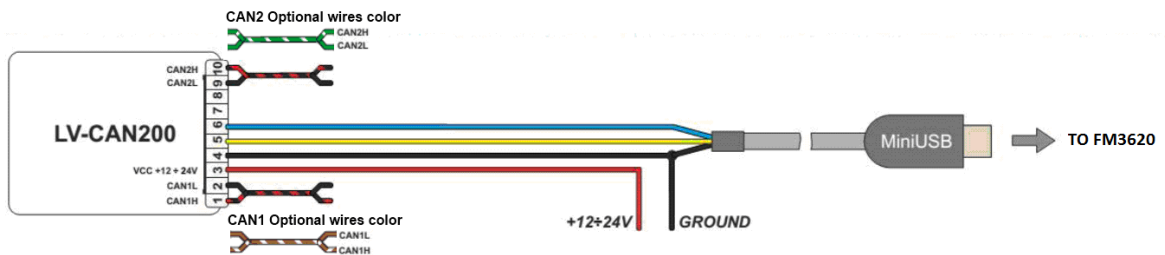

Figure 56 LV-CAN200 Adapter connection cable pinout

Attention! For detailed connection diagram of adapter to light vehicle please contact Teltonika, LTD sales representative and provide CAR manufacturer, model and year information.



Attention! Do not swap CAN L and CAN H lines.
Do not swap power supply lines. Make sure that voltage do not exceeds 30V.
Power supply lines should be connected at the end of installation work.

9.4 FM11 Configuration

FM3600 shares the same USB port for connecting LV-CAN200 adapter and configuring device with PC.

FM3600 can be configured using “SCAN” function or “Offline Configuration” (Figure 58)

SCAN function – is in use when FM3600 is connected to CAN adapter (Figure 57), then wait 10s (Note, that car engine must be started), disconnect adapter from FM3600, and connect PC USB cable to FM3600 Device (Figure 58). It is very important not to disconnect FM3600 from power source during this operation, because if FM3600 is reconnected all received CAN bus data will be lost. FM3600 remembers received data from LV-CAN200 and at the end of the procedure when “SCAN” button is pressed, user will see all CAN data which is sent by adapter. Enable CAN data which needs send to server and save configuration pressing “Save” button.

To configure CAN data:

1. In car, connect LV-CAN200 to CAN bus and to the FM3600 device (Figure 57), wait 10 seconds. Note, that car engine must be started.
2. Disconnect LV-CAN200 from FM3600, and connect PC USB cable to FM3600 Device (Figure 58). It is very important not to disconnect FM3600 from power source, because then all CAN data will be lost.

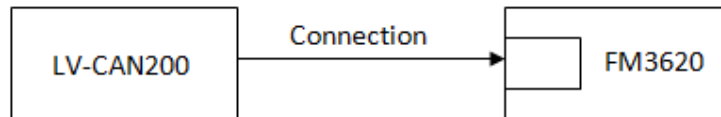

Figure 57 Connect adapter LV-CAN100 to FM3600

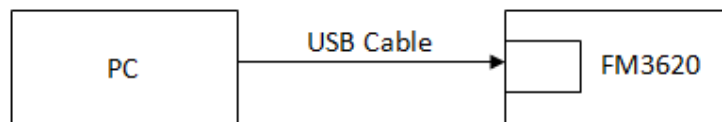

Figure 58 Connect FM3600 to PC and configure

CAN bus data which can be read from your car is shown in “Light Vehicles Can adapter supported cars” document.

Offline configuration – user can select which CAN data can be read from LV-CAN200 need to be sent to server without connection to adapter. Please note that parameters depend on vehicle manufacturer and vehicle model. Please for further information check “Light Vehicles Can adapter supported cars” document.

There are two types of operations with CAN data elements:

- Monitoring of CAN bus data

- CAN bus data event capturing

Monitoring method is used when user wants to receive CAN data on regular basis, for example every 20 seconds.

Event functionality is used to store additional AVL packet when state of CAN element is changing. For example Speed changes, low fuel level, engine temperate, etc.

Send data to server field – allows enabling CAN element so it is added to the AVL data packet and sent to the server. By default, all CAN elements are disabled and FM3600 records only GPS data.

It is possible to set CAN message priority: On Low Priority, On High Priority, and On Panic. Regular packets are sent as Low priority records. When low priority event is triggered, FM3600 makes additional record with indication what was the reason for that was CAN element change. When High priority is selected, module makes additional record with high priority flag and sends event packet immediately to the server by GPRS. Panic priority triggers same actions as high priority, but if GPRS fails, it sends AVL packet to server using SMS mode if SMS is enabled in SMS settings.

Data Acquisition Type – defines when to generate event – when value enters defined range, exits it or both, also is possible to select event which you want to generate then you change values, like crossing both values in high and low levels (Hysteresis).

High and Low levels – defines CAN value range. If CAN value enter or exits this range, FM3600 generates event by “Data Acquisition Type” settings. Figure 59 show example of FM3600 CAN configuration.

System	I/O	Property Input	Enabled	Priority	Low Level	High Level	Generate Event	Averaging Constant
Records		Vehicle speed	<input checked="" type="checkbox"/>	Low	0	0	Monitoring	10
GSM		Accelerator pedal position	<input type="checkbox"/>	Disabl	0	0	Monitoring	2
DataAcquisitionModes		Fuel Consumed	<input type="checkbox"/>	Disabl	0	0	Monitoring	
Features		Fuel level (liters)	<input type="checkbox"/>	Disabl	0	0	Monitoring	10
		Engine RPM	<input type="checkbox"/>	Disabl	0	0	Monitoring	10
IO		Total mileage	<input type="checkbox"/>	Disabl	0	0	Monitoring	
		Fuel level (%)	<input type="checkbox"/>	Disabl	0	0	Monitoring	10
LVCAN		Program number	<input type="checkbox"/>	Disabl	0	0	Monitoring	
		Module ID	<input type="checkbox"/>	Disabl	0	0	Monitoring	
		Engine worktime	<input checked="" type="checkbox"/>	Low	0	0	Monitoring	
		Engine worktime (counted)	<input type="checkbox"/>	Disabl	0	0	Monitoring	
		Total mileaoe (counted)	<input type="checkbox"/>	Disabl	0	0	Monitoring	

Figure 59 Configurator example

Available CAN Bus IO parameters and configuration can be found in Configurators CAN tab (Figure 58) and in next chapter “Parameters ID”.

9.5 Parameters ID

When no I/O element is enabled, AVL packet comes with GPS information only. After enabling I/O element(s) AVL packet along with GPS information contains current value(s) of enabled I/O element. AVL packet decoding is described in “FMXXX Protocols” document. List of available CAN bus data, parameter size, ID and value range you can find in table 9.1

Table 9.1 ACQUIRED PARAMETERS IO ID

Category name	(signal) name	Size (Bytes)	Param IO ID	Value range
65265 – Cruise Control/Vehicle Speed	Vehicle Speed	1	2290	0-250 km/h*
61443 – Electronic Engine Controller #2	Accelerator Pedal Position	1	2300	0-100 %*
65257 – Fuel Consumption	Total Fuel Used	4	2310	0-99999999liters*
65276 – Dash Display	Fuel Level [liters]	2	2320	0-100 liters*
61444 – Electronic Engine Controller #1	Engine RPM	2	2330	0-8200 rpm*
65217 – High Resolution Vehicle Distance	Vehicle Distance	4	2340	0-2145000000 meters*
65276 – Dash Display	Fuel Level [%]	1	2350	0-100 %*
Program number	LV-CAN200 Program number	4	2360	0-999

NOTE:

„Total Fuel Used“ is sent to server multiplied by 10.

Example: if value was 150.5 liters, „1505“ will be sent to server.

9.6 SMS Configuration

All LV-CAN200 IO elements can be configured remotely via SMS command. ID number refers to specific LV-CAN200 IO element (table 9.2). The last ID number refers to sections – Property; Generation Type; Low and High levels (Table 9.3).

Here’s example:

ID 2013 – configures Accelerator Pedal position parameter “High Level”.

Table 9.2 LV-CAN200 IO elements SMS configuration Ids range

LV-CAN200 IO Element	Parameter Ids range
Speed	2290-2294
Accelerator pedal position	2300-2304
Total fuel used	2310-2313
Fuel level (liters)	2320-2324
Engine RPM	2330-2334
Vehicle distance	2340-2343

Fuel level (proc.)	2350-2354
Program number	2360-2363

Table 9.3 LV-CAN200 IO parameters configuration

Parameter ID	Parameter name	Available values
2xx0	Priority	0 – IO element disabled 1 – Low priority 1 – High priority 3 – Panic priority
2xx1	Generation type	0 – Event on exit 1 – Event on entrance 2 – Event on both 3 – Monitoring 4 – Hysteresis 5 – On change
2xx2	Low level	See table 9.4 – Allowed Values
2xx3	High Level	

Table 9.4 LV-CAN200 IO parameters allowed values

LV-CAN200 IO Element	Minimum value	Maximum value
Speed	0	250
Accelerator pedal position	0	100
Total fuel used	0	99999999
Fuel level (liters)	0	100
Engine RPM	0	8200
Vehicle distance	0	2145000000
Fuel level (proc.)	0	100
Program number	0	999

9.7 CAN Program Number request by SMS

CAN program number can be obtained via SMS:

SMS Text: "lvcagetprog"

Response: "CAN Program Nr: XXX"

9.8 Get LV-CAN info by SMS

Full LV-CAN information via SMS:

SMS Text: "lvcagetinfo"

Response:

"Prog: 139

SWRevison: 6

KernVer: 10

KernVar: 49

MdIID: 8884443332221110"

9.9 References

1. Light Vehicles Can adapter LV-CAN200 Supported cars
2. Cars mounting scheme

MOUNTING RECOMMENDATIONS

9.10 Connecting Wires

- Wires should be connected while module is not plugged in.
- Wires should be fastened to the other wires or non-moving parts. Try to avoid heat emitting and moving objects near the wires.
- The connections should not be seen very clearly. If factory isolation was removed while connecting wires, it should be applied again.
- If the wires are placed in the exterior or in places where they can be damaged or exposed to heat, humidity, dirt, etc., additional isolation should be applied.
- Wires cannot be connected to the board computers or control units.

9.11 Connecting Power Source

- Be sure that after the car computer falls asleep, power is still available on chosen wire. Depending on car, this may happen in 5 to 30 minutes period.
- When module is connected, be sure to measure voltage again if it did not decrease.
- It is recommended to connect to the main power cable in the fuse box.

9.12 Connecting Ignition Wire

- Be sure to check if it is a real ignition wire – power does not disappear while starting the engine.
- Check if this is not an ACC wire (when key is in the first position, most electronics of the vehicle are available).
- Check if power is still available when you turn off any of vehicles devices.
- Ignition is connected to the ignition relay output. As alternative, any other relay, which has power output, when ignition is on, may be chosen.

9.13 Connecting Ground Wire

- Ground wire is connected to the vehicle frame or metal parts that are fixed to the frame.
- If the wire is fixed with the bolt, the loop must be connected to the end of the wire.
- For better contact scrub paint from the place where loop is connected.



PAY ATTENTION! Connecting the power supply must be carried out in a very low impedance point on-board vehicle network. These points in the car are the battery terminals. Therefore, we recommend connecting the power of FM3600 (wire GND and POWER) directly to the battery terminals. Another valid option is to connect the wires to the main POWER cable inside the fuse box (if there is none, then to the power supply where the fuses of vehicle's computer are), wire GND must be connected in a special point, designed to connect GND vehicle computer. Connecting the GND at an arbitrary point to the mass of the car is unacceptable, as static and dynamic potentials on the line GND will be unpredictable, which can lead to unstable FM3600 and even its failure.

9.14 Connecting Antennas

- When placing antennas avoid easily reached places.
- Avoid GNSS antenna placement under metal surfaces.
- Avoid placing FM3600 device near car radio, speakers or alarm systems.
- GNSS antenna must be placed so its state is as horizontal as possible (if antenna is leant more than 30 degrees, it is considered incorrect mounting).
- GNSS antenna cable cannot be bent more than 80 degrees.
- GNSS antenna must be placed sticker facing down



Figure 60 Correct GNSS antenna mounting

It is recommended to place GNSS antenna behind dashboard as close to the window as possible. A good example of GNSS antenna placement is displayed in a picture below (area colored green).

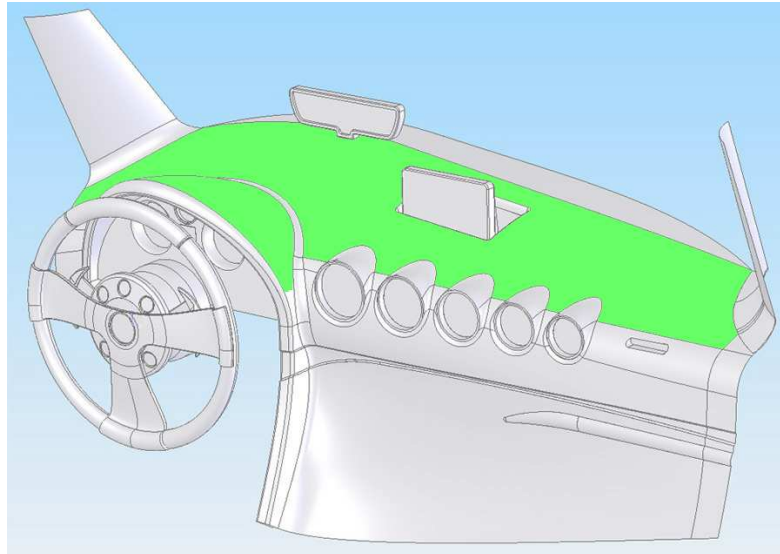

Figure 61 Correct placement of FM3600

9.15 Module Installation

- Module should not be seen or easily reached.
- Module should be firmly fixed to the surface or cables.
- Module cannot be fixed to heat emitting or moving parts.
- SIM card should be inserted in the module while the connector is plugged off (while module has no power).

10 CHANGE LOG

Nr.	Date	Version	Comments
1	2016-10-13	1.0	Document created
2	2017-02-08	1.1	Updated "setdigout" sms command
3	2017-10-31	1.2	Added LV -CAN200/ALLAN300 migration to 4 digit program nr. information