



FMB001 User Manual

V0.12

Table of contents

1	INTRODUCTION	7
1.1	ATTENTION	7
1.2	INSTRUCTIONS OF SAFETY	7
1.3	LEGAL NOTICE	8
1.4	ABOUT DOCUMENT	8
2	BASIC DESCRIPTION	8
2.1	BASIC CHARACTERISTICS	9
2.2	TECHNICAL FEATURES.....	10
2.3	TECHNICAL INFORMATION ABOUT INTERNAL BATTERY.....	11
2.4	ELECTRICAL CHARACTERISTICS.....	12
2.5	ABSOLUTE MAXIMUM RATINGS.....	12
3	CONNECTION, PINOUT, ACCESSORIES.....	13
3.1	HOW TO INSERT MICRO SIM CARD INTO FMB001 DEVICE:.....	13
3.2	INSTALLING FMB001 DRIVERS	15
3.3	OBD II	17
3.4	NAVIGATE LED.....	18
3.5	STATUS LED	18
4	OPERATIONAL BASICS.....	18
4.1	OPERATIONAL PRINCIPALS.....	18
4.2	SLEEP MODE	18
4.2.1	<i>Sleep mode</i>	18
4.2.2	<i>Deep Sleep mode</i>	19
4.2.3	<i>Online Sleep mode</i>	19
4.3	VIRTUAL ODOMETER.....	19
4.4	FEATURES.....	20
4.4.1	<i>Green Driving/Eco Driving Scenario</i>	20
4.4.2	<i>Over Speeding Scenario</i>	21
4.4.3	<i>Excessive Idling</i>	21
4.4.4	<i>Jamming detection</i>	21
4.4.5	<i>Trip</i>	21
4.5	ACCELEROMETER SCENARIOS.....	21
4.5.1	<i>Towing Detection</i>	21
4.5.2	<i>Unplug Detection</i>	21
4.5.3	<i>Crash Detection</i>	22
4.5.3.1	Crash Trace operation	22
4.5.3.2	Bluetooth	22
5	CONFIGURATION	22
5.1	CONFIGURATOR.....	22
5.1.1	<i>System settings</i>	24
5.1.2	<i>Records settings</i>	27
5.1.3	<i>GSM settings, GPRS part</i>	27
5.1.4	<i>GSM settings, SMS part</i>	28
5.1.5	<i>GSM settings, Operator list</i>	32
5.2	FEATURES SETTINGS.....	33
5.2.1	<i>Trip settings</i>	36
5.2.2	<i>AutoGeofencing settings</i>	37
5.2.3	<i>GPS Fuel Counter</i>	39
5.2.4	<i>Scenarios Accelerometer</i>	39
5.2.5	<i>OBD II</i>	42
5.2.6	<i>Bluetooth</i>	43
5.2.6.1	Connecting to device via Bluetooth.....	44
5.2.6.2	How to connect Bluetooth Hands Free adapter to FMB device	44

5.2.6.3	Device's log using your mobile phone.....	46
5.2.6.4	How to connect OBD II Bluetooth Dongle to FMB device.....	49
5.2.7	Data Acquisition Mode settings.....	51
5.3	OBD FUNCTIONALITY DESCRIPTION.....	55
5.3.1	Supported OBD protocols.....	55
5.3.2	General info.....	55
5.3.3	Initialization.....	55
5.3.4	Data.....	55
5.4	I/O SETTINGS.....	55
6	SMS COMMAND LIST.....	57
6.1	SMS COMMAND LIST.....	57
6.1.1	<i>getinfo</i>	59
6.1.2	<i>getver</i>	59
6.1.3	<i>getstatus</i>	59
6.1.4	<i>getgps</i>	59
6.1.5	<i>ggps</i>	60
6.1.6	<i>radio #</i>	60
6.1.7	<i>getparam</i>	60
6.1.8	<i>setparam</i>	60
6.1.9	<i>flush #,#,#,#,#,#</i>	60
6.1.10	<i>setdigout</i>	61
6.1.11	<i>countrecs</i>	61
6.1.12	<i>towingreact</i>	61
6.1.13	<i>faultcodes</i>	61
6.1.14	<i>obdinfo</i>	62
6.1.15	<i>btgetlist</i>	62
6.1.16	<i>cleardtc</i>	62
6.2	SYSTEM PARAMETERS.....	62
6.2.1	<i>Sleep Mode (ID=102)</i>	62
6.2.2	<i>Sleep timeout (ID=103)</i>	62
6.2.3	<i>Movement Source (ID=100)</i>	63
6.2.4	<i>Static Navigation (ID=106)</i>	63
6.2.5	<i>Static Navigation Settings (ID=112)</i>	63
6.2.6	<i>Saving/Sending without time synchronization (ID=107)</i>	63
6.2.7	<i>GNSS Source (ID=109)</i>	63
6.2.8	<i>Ignition settings (ID=101)</i>	64
6.2.9	<i>High voltage level (ID=104)</i>	64
6.2.10	<i>Low voltage level (ID=105)</i>	64
6.2.11	<i>Led indication (ID=108)</i>	64
6.2.12	<i>Battery charge mode (ID=110)</i>	64
6.3	RECORDS PARAMETERS.....	65
6.3.1	<i>Sorting (ID=1002)</i>	65
6.3.2	<i>Open Link Timeout (ID=1000)</i>	65
6.3.3	<i>Server Response Timeout (ID=1001)</i>	65
6.4	GSM PARAMETERS.....	65
6.4.1	<i>GPRS content activation (ID=2000)</i>	65
6.4.2	<i>APN Name (ID=2001)</i>	66
6.4.3	<i>APN username (ID=2002)</i>	66
6.4.4	<i>APN Password (ID=2003)</i>	66
6.4.5	<i>Domain (ID=2004)</i>	66
6.4.6	<i>Target Server Port (ID=2005)</i>	66
6.4.7	<i>Protocol (ID=2006)</i>	67
6.5	SMS/CALL SETTINGS.....	67
6.5.1	<i>SMS data sending settings (ID=3000)</i>	67
6.5.2	<i>Data send number (ID=3001)</i>	67
6.5.3	<i>Authorized phone numbers (ID=4000-4009)</i>	67
6.5.4	<i>SMS Event Predefined Numbers (ID=6000-6009)</i>	67

6.5.5	SMS Login (ID=3003)	68
6.5.6	SMS Password (ID=3004).....	68
6.5.7	Incoming call action (ID=3005).....	68
6.5.8	Outgoing Call Trigger (ID=3007).....	68
6.5.9	GSM number index (ID=3008)	68
6.5.10	Operator List (ID=5000-5049).....	68
6.6	DATA ACQUISITION MODES PARAMETERS.....	69
6.6.1	Home Network GSM operator code "Vehicle on STOP" parameters.....	69
6.6.1.1	Min Period (ID=10000).....	69
6.6.1.2	Min Saved Records (ID=10004).....	69
6.6.1.3	Send Period (ID=10005).....	69
6.6.2	Home Network GSM operator code "Vehicle MOVING" parameters.....	69
6.6.2.1	Min Period (ID=10050).....	69
6.6.2.2	Min Distance (ID=10051)	69
6.6.2.3	Min Angle (ID=10052).....	70
6.6.2.4	Min Speed delta (ID=10053)	70
6.6.2.5	Min Saved Records (ID=10054).....	70
6.6.2.6	Send Period (ID=10055).....	70
6.6.3	Roaming Network GSM operator code "Vehicle on STOP" parameters	70
6.6.3.1	Min Period (ID=10100).....	70
6.6.3.2	Min Saved Records (ID=10104).....	71
6.6.3.3	Send Period (ID=10105).....	71
6.6.4	Roaming Network GSM operator code "Vehicle MOVING" parameters	71
6.6.4.1	Min Period (ID=10150).....	71
6.6.4.2	Min Distance (ID=10151)	71
6.6.4.3	Min Angle (ID=10152).....	71
6.6.4.4	Min Speed (ID=10153)	72
6.6.4.5	Min Angle (ID=10152).....	72
6.6.4.6	Min Saved Records (ID=10154).....	72
6.6.4.7	Send Period (ID=10155).....	72
6.6.5	Unknown Network GSM operator code "Vehicle on STOP" parameters	72
6.6.5.1	Min Period (ID=10200).....	72
6.6.5.2	Min Saved Records (ID=10204).....	72
6.6.5.3	Send Period (ID=10205).....	72
6.6.6	Unknown Network GSM operator code "Vehicle MOVING" parameters	73
6.6.6.1	Min Period (ID=10250).....	73
6.6.6.2	Min Distance (ID=10151)	73
6.6.6.3	Min Distance (ID=10251)	73
6.6.6.4	Min Angle (ID=10152).....	73
6.6.6.5	Min Period (ID=10150)	73
6.6.6.6	Min Angle (ID=10252).....	73
6.6.6.7	Min Speed (ID=10253)	74
6.6.6.8	Min Distance (ID=10151)	74
6.6.6.9	Min Saved Records (ID=10254).....	74
6.6.6.10	Send Period (ID=10255).....	74
6.7	FEATURES PARAMETERS.....	74
6.7.1	Green driving priority (ID=11000).....	74
6.7.2	Max Acceleration Force (ID=11004)	74
6.7.3	Max Braking Force (ID=11005).....	75
6.7.4	Max Cornering (ID=11006)	75
6.7.5	Green/Eco driving (ID=11007)	75
6.7.6	Green driving digital output control settings (ID=11003).....	75
6.7.7	Green driving Digital output on duration (ID=11001)	75
6.7.8	Green driving Digital output off duration (ID=11002)	75
6.7.9	Overspeeding priority (ID=11100)	76
6.7.10	Max allowed Speed (ID=11104).....	76
6.7.11	Overspeeding output control (ID=11103)	76
6.7.12	Overspeeding Digital output on duration (ID=11101)	76
6.7.13	Overspeeding Digital output off duration (ID=11102).....	76
6.7.14	Excessive idling priority (ID=11200).....	76

6.7.15	Eventual records (ID=11203)	77
6.7.16	Excessive idling minimum stop duration (ID=11205).....	77
6.7.17	Excessive idling minimum move duration (ID=11206).....	77
6.7.18	Excessive idling output control (ID=11204)	77
6.7.19	Excessive idling output on duration (ID=11201)	77
6.7.20	Excessive idling output off duration (ID=11202).....	77
6.7.21	Jamming (ID=11300)	78
6.7.22	Jamming Eventual records (ID=11303).....	78
6.7.23	Jamming Output Control (ID=11304)	78
6.7.24	Jamming DOUT on duration [ms] (ID=11301)	78
6.7.25	Jamming DOUT off duration [ms] (ID=11302).....	78
6.7.26	DOUT control via call (ID=12000)	78
6.7.27	DOUT deactivation settings (ID=12001)	79
6.7.28	DOUT duration timeout [s] (ID=12002)	79
6.7.29	Trip priority priority (ID=11800)	79
6.7.30	Start Speed (ID=11803).....	79
6.7.31	Ignition Off Timeout (ID=11804).....	79
6.7.32	Trip mode (ID=11802).....	79
6.8	AUTOGEOFENCING.....	80
6.8.1.1	AutoGeofencing priority (ID=20000)	80
6.8.1.2	Activation Timeout (ID=20003)	80
6.8.1.3	Deactivate by (ID=20005)	80
6.8.1.4	AutoGeofence event generating (ID=20001)	80
6.8.1.5	Radius (ID=20004).....	80
6.9	GPS FUEL COUNTER	80
6.9.1.1	City Consumption L/100km (ID=11900)	80
6.9.1.2	Highway Consumption L/100km (ID=11901).....	81
6.9.1.3	Average Consumption L/100km (ID=11902)	81
6.9.1.4	City Speed [km/h] (ID=11903)	81
6.9.1.5	Highway Speed [km/h] (ID=11904)	81
6.9.1.6	Average Speed [km/h] (ID=11905)	81
6.9.1.7	Correction coefficient (ID=11906)	81
6.9.1.8	Fuel Consumption on Idling [L/h] (ID=11907)	81
6.9.1.9	Higher Speeds Add [%] (ID=11908).....	82
6.9.1.10	Highway Consumption every km/h (ID=11909)	82
6.10	SCENARIOS ACCELEROMETER.....	82
6.10.1	Unplug Detection.....	82
6.10.1.1	Scenario settings (ID=11500)	82
6.10.1.2	Eventual records (ID=11501)	82
6.10.1.3	Unplug detection mode (ID=11502)	82
6.10.1.4	Send sms to (ID=7067).....	82
6.10.1.5	SMS Text (ID=8067)	82
6.10.2	Crash Detection	83
6.10.2.1	Scenario settings (ID=11400)	83
6.10.2.2	Duration [ms] (ID=11401)	83
6.10.2.3	Threshold [mG] (ID=11402)	83
6.10.2.4	Crash trace (ID=11406)	83
6.11	BLUETOOTH	83
6.11.1.1	BT Radio (ID=800)	83
6.11.1.2	Local name (ID 801).....	83
6.11.1.3	Local PIN (ID=802).....	83
6.11.1.4	Security mode (ID=803)	84
6.11.1.5	External MAC (ID=804)	84
6.11.1.6	External name (ID=805)	84
6.11.1.7	External PIN (ID=806).....	84
6.11.1.8	Connection mode (ID=807).....	84
6.11.1.9	Authorized devices MAC list (ID=830 - 834)	84
6.12	I/O PARAMETERS.....	85
6.12.1	I/O#1 property parameter Ignition (ID=50000)	85
6.12.2	I/O#1 Logic operand (ID=50001)	85
6.12.3	I/O#1 High level (ID=50002)	85

6.12.4	I/O#1 Low level (ID=50003)	85
6.12.5	I/O#1 Event only (ID=50004)	86
6.12.6	I/O#1 averaging length (ID=50005).....	86
6.13	I\O ELEMENTS PARAMETERS AND TYPES.	87
6.14	OBD ELEMENTS PARAMETERS AND TYPES	91
CHANGE LOG		96

1 INTRODUCTION

1.1 Attention



Do not disassemble the device. If the device is damaged, before unplugging the power supply, do not touch the device.



All wireless data transferring devices produce interference that may affect other devices which are placed nearby.



Please consult representatives of your vehicle model regarding OBD II location on your vehicle. In case you are not sure of proper connection, please consult qualified personnel.



The programming must be performed using a second class PC (with autonomic power supply).



The device is susceptible to water and humidity.



Any installation and/or handling during a lightning storm are prohibited.



FMB001 has USB interface;
Teltonika is not responsible for any harm caused by using wrong cables for PC <-> FMB001 connection.



Warning! Do not use FMB001 device if it distracts driver or causes inconvenience due to OBD II placement. Device must not interfere with driver.

1.2 Instructions of safety

This chapter contains information on how to operate FMB001 safely. By following these requirements and recommendations, you will avoid dangerous situations. You must read these instructions carefully and follow them strictly before operating the device!

The device uses a 10 V...16 V DC power supply. The nominal voltage is 12 V DC. The allowed range of voltage is 10 V...16 V DC.

To avoid mechanical damage, it is advised to transport the FMB001 device in an impact-proof package.

Before dismounting the device from the vehicle, ignition must be off.

1.3 Legal Notice

Copyright © 2017 Teltonika. All rights reserved. Reproduction, transfer, distribution or storage of part or all of the contents in this document in any form without the prior written permission of Teltonika is prohibited.

Other products and company names mentioned here may be trademarks or trade names of their respective owners.

The manufacturer reserves the right to make changes and/or improvements at any time in design, functionality, parameters and electrical characteristics without any prior notice and without incurring obligations.

1.4 About document

This document contains information about the architecture, possibilities, mechanical characteristics, and configuration of the FMB001 device.

Acronyms and terms used in document:

PC – Personal Computer;

GPS – Global Positioning System;

GPRS – General Packet Radio Service;

GNSS – Global Navigation Satellite System;

GSM – Global System for Mobile Communications;

SMS – Short Message Service;

AC/DC – Alternating Current/Direct Current;

I/O – Input/Output;

Record – AVL data stored in FMB001 memory. AVL data contains GNSS and I/O information;

AVL packet - data packet which is being sent to the server during data transmission.

2 BASIC DESCRIPTION

FMB001 is tracking terminal with GNSS and GSM connectivity, which is able to collect device coordinates and transfer them via GSM network to server. This device is perfectly suitable for applications, which need location acquirement of remote objects. . It is important to mention that FMB001 has standard OBD-II interface which lets you to monitor basic vehicle parameters. FMB001 also has a USB port for device status log output and entering configurations.



Note: Monitorable basic vehicle parameters depend on vehicle mark and model.

Package contents¹

The FMB001 device is supplied to the customer in a cardboard box containing all the equipment that is necessary for operation. The package contains:

Already implemented FMB001 device into case;

Top and bottom device cover parts;

128MB Micro SD card;

OBD II power supply adapter.

¹ Package content depends on Order Code, and can be customized by customer needs.

2.1 Basic characteristics

GSM / GPRS / GNSS features:

- Teltonika TM2500 quad band module (GSM 850 / 900 / 1800 / 1900 MHz);
- GPRS class 12;
- SMS (text, data).
- Integrated GNSS receiver
- Up to -162 dBm GNSS receiver sensitivity.

Hardware features:

- Built-in movement sensor;
- Built-in Bluetooth 3.0;
- Internal High Gain GNSS antenna;
- Internal High Gain GSM antenna;
- microSD card reader;
- 170 mAh Li-ion rechargeable 3.7 V battery;
- OBD II interface.

Interface features:

- Power supply: 10 ÷ 16V;
- 1 digital input;
- CAN;
- K-LINE;
- USB port
- OBD II;
- 2 LEDs indicating device status.

Special features:

- Fast position fix;
- High Quality track even in high density urban canyon;
- Small case;
- High gain internal GNSS and GSM antennas;
- 2 LED status indication;
- Real-Time tracking;
- Smart data acquisition based on:
 - Time;
 - Angle;
 - Distance;
 - Ignition or any other I/O event;
- Sending acquired data via GPRS;
- GPRS and SMS I/O events;

- Virtual odometer;
- Jamming detection;
- Configurable using Secured SMS Commands;
- Spy call;
- Overvoltage protection.

2.2 Technical features

Part name	Physical specification	Technical details
Navigation LED	LED	Technical details Power supply 10...16 V DC 2 W Max Energy consumption ¹ : GPRS: --- 50 mA r.m.s Max., Nominal: --- average 35 mA r.m.s, GPS Sleep: --- average 12 mA, Deep Sleep: --- average 4.5 mA ² Battery charge current: --- average 120 mA, Rated current: --- 250 mA, Operation temperature: -25 °C ... +55 °C Storage temperature: -40 °C ... +70 °C Storage relative humidity 5 ... 95 % (no condensation) Internal fuse: 3A, 125V
Modem LED	LED	
OBD-II connector	Standard OBD-II connector	
USB	Mini USB socket	

Table 1. FMB001 specifications

¹ Energy consumption has been tested at 12V voltage with no battery charging.

² When in Deep Sleep mode no data storing and sending is activated.

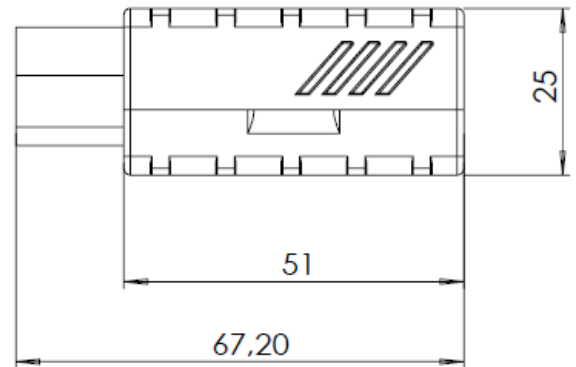
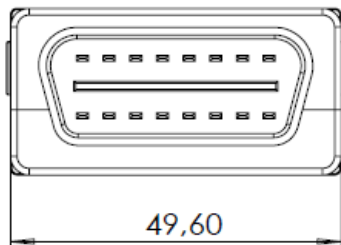
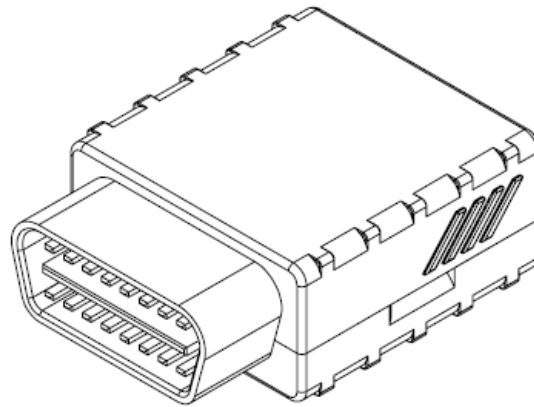

Figure 1 FMB001 view & dimensions (tolerance $\pm 2\text{mm}$)

2.3 Technical Information about internal battery

Li-Polymer rechargeable battery, 3.7 V, 170 mAh.

Internal back-up battery	Battery voltage V	Nominal capacity (mAh)	Power(Wh)	Charging temperature °C
Li-Polymer rechargeable battery	3.75 ~ 3.90	≥ 170	0.64 - 0.66	0 - 45

Table 2 Battery specifications

FMB001 internal battery is used for detecting external voltage disconnection.



CAUTION: RISK OF EXPLOSION IF BATTERY IS REPLACED BY AN INCORRECT TYPE. DISPOSE OF USED BATTERIES ACCORDING TO THE INSTRUCTIONS.

2.4 Electrical characteristics

CHARACTERISTIC DESCRIPTION	VALUE	Min.	Typ.	Max.	Unit
Supply Voltage:					
Supply Voltage (Recommended Operating Conditions)		10		16	V
Digital Input:					
Input resistance (DIN1)		15			kΩ
Input Voltage (Recommended Operating Conditions)		0		Supply voltage	V
Input Voltage threshold (DIN1)			5		V

2.5 Absolute Maximum Ratings

CHARACTERISTIC DESCRIPTION	VALUE	Min.	Typ.	Max.	Unit
Supply Voltage (Absolute Maximum Ratings)		-16		16	V
Digital Input Voltage (Absolute Maximum Ratings)		-32		32	V

3 CONNECTION, PINOUT, ACCESSORIES

3.1 How to insert micro SIM card into FMB001 device:

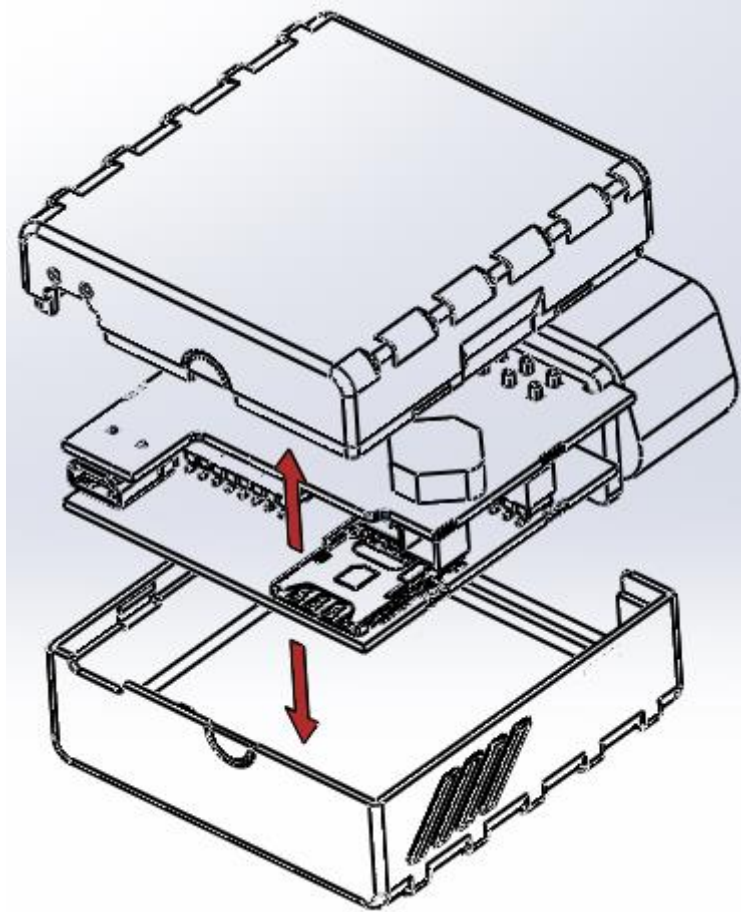

① Remove FMB001 cover

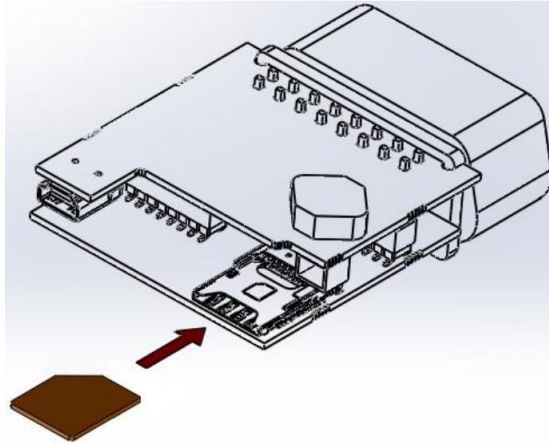

② Insert micro SIM card as shown (bottom slot)

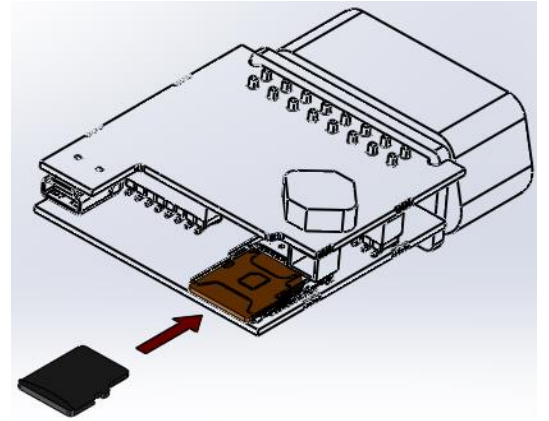

③ Insert SD card as shown (top slot)

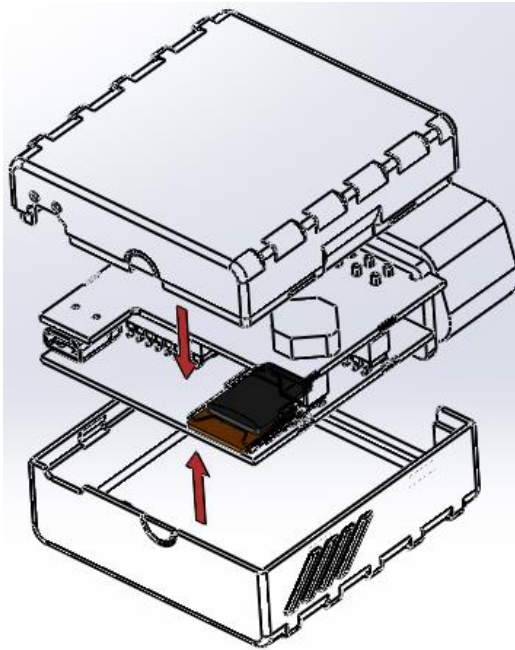

③ Attach cover

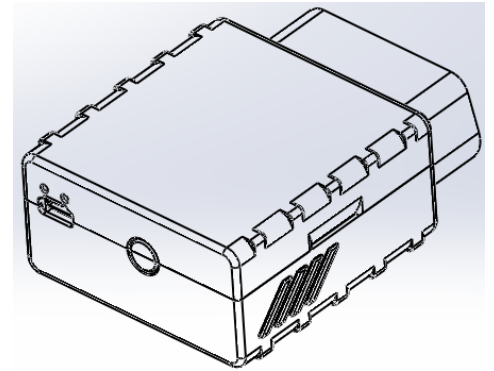

④ Device is ready

3.2 Installing FMB001 drivers

Software requirements:

- Operating system 32-bit and 64-bit: Windows XP with SP3 or later, Windows Vista, Windows 7.
- MS .NET Framework V3.5 or later (<http://www.microsoft.com> or <http://av11.teltonika.lt/downloads/tav/Framework/dotnetfx35setupSP1.zip>).

Drivers:

Please download MediaTek inbox COM Port drivers from Teltonika website: http://av11.teltonika.lt/downloads/FMB0/MS_USB_ComPort_Driver_exe_v1.1032.3.zip

Installing drivers:

Extract and run FP_INBOX_InstallDriver_v1.1032.3.exe. This driver is used to detect FMB001 device connected to the computer. Click 'Next' in driver installation window (figures below):

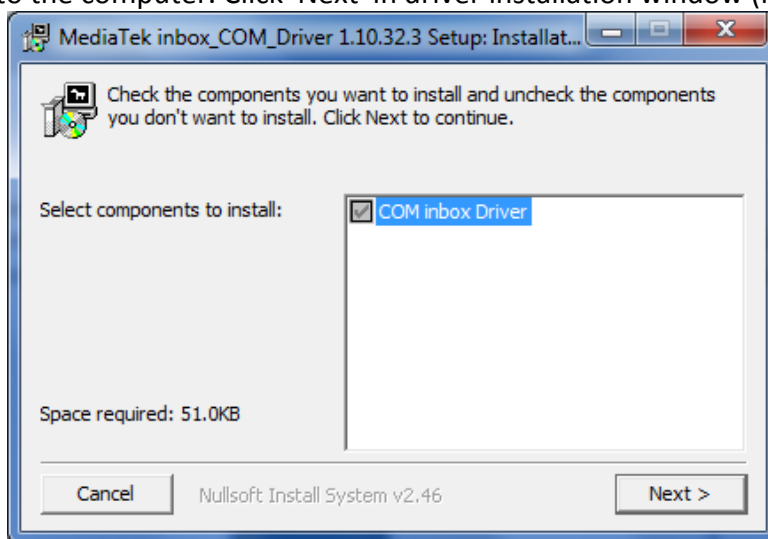

Figure 2 Driver installation window

This will launch device driver installation wizard. In the following window click 'Install' button:

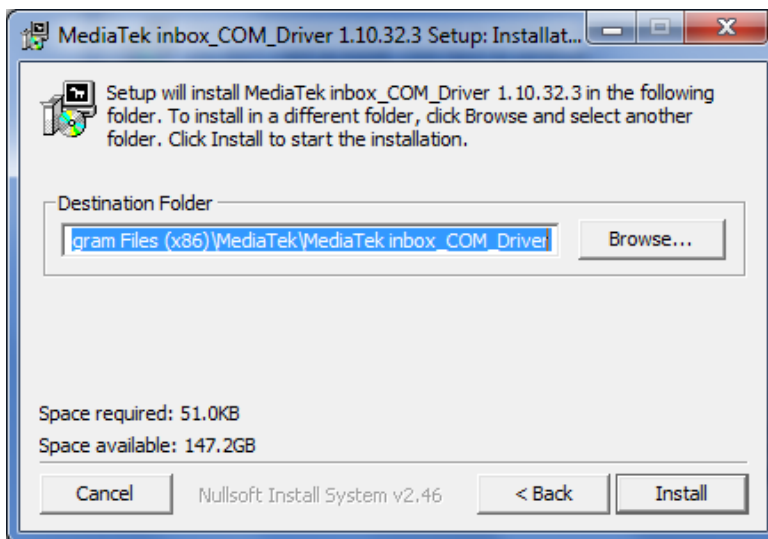

Figure 3 Driver installation window

Setup will continue installing drivers and will display a window about successful process at the end. Click 'Finish' to complete setup:

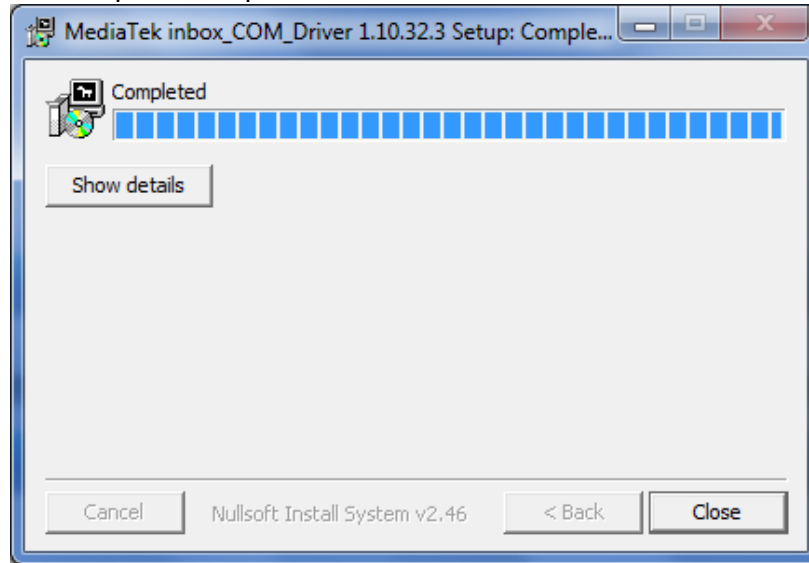

Figure 4 Driver installation window

You have now installed drivers for FMB001 device successfully.

3.3 OBD II

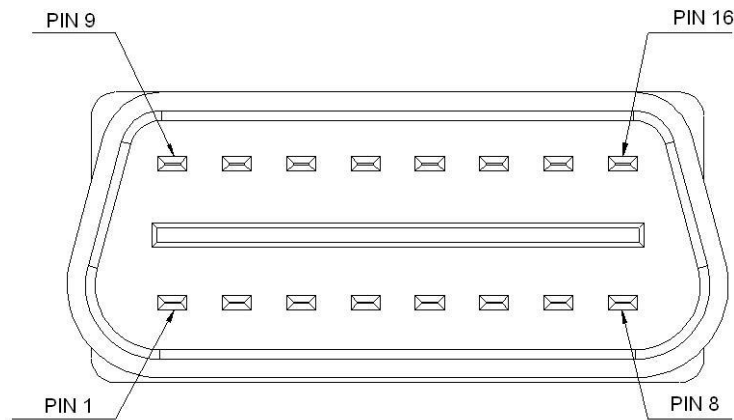

Figure 5 OBD II pinout

Pin Nr.	Pin Name	Description
1	Ignition input	
2	PWM_BUS+/VPW	
3	-	
4	GND (-)	Ground pin.
5	GND (-)	Ground pin.
6	CAN_H	
7	K-Line	
8	-	
9	-	
10	PWM_BUS-	
11	-	
12	-	
13	-	
14	CAN_L	
15	L-Line	
16	Power +(10÷16) V DC	Power range +(10...16) V DC to ground

Table 3 FMB001 pinout description

3.4 Navigate LED

Behavior	Meaning
Permanently switched on	GNSS signal is not received
Blinking every second	Normal mode, GNSS is working
Off	GNSS is turned off because: <ul style="list-style-type: none"> • Deep sleep mode Or <ul style="list-style-type: none"> • GNSS antenna short circuited

3.5 Status LED

Behavior	Meaning
Blinking every second	Normal mode
Blinking every 2 seconds	Deep sleep mode
Blinking fast for a short time	Modem activity
Blinking fast constantly	Boot mode
Off	<ul style="list-style-type: none"> • Device is not working Or <ul style="list-style-type: none"> • Device firmware being flashed

4 OPERATIONAL BASICS

4.1 Operational principals

FMB001 module is designed to acquire records and send them to the server. Records contain GNSS data and I/O information. Module uses GNSS receiver to acquire GNSS data and is powered with three data acquiring methods: time-based, distance-based and angle-based. Note, that if FMB001 loses connection to GNSS satellites, it continues to make records, however coordinate in these records remains the same (last known coordinate). All data is stored in flash memory and later can be sent via GPRS.

GPRS and SMS settings are described in later sections. FMB001 communicates with server using special data protocol.

FMB001 can be managed by SMS commands. SMS Command list is described in SMS COMMAND LIST section. Module configuration can be performed only via SMS.

4.2 Sleep mode

4.2.1 Sleep mode

FMB001 is able to go to sleep mode if such mode is enabled.

This timeout (defined period) starts counting when device is in STOP mode. After timeout is reached and all conditions for sleep mode are met, device goes to sleep mode. While in sleep mode, FMB001 turns GPS module off and it is still making new periodic records. As a result power usage decreases, in turn saving vehicle battery.

FMB001 can enter sleep mode if **ALL** of these conditions are met:

- FMB001 has to be configured to work in Sleep mode and start sleep timeout is reached;

- Device must have synchronized time with GNSS satellites;
- No movement by movement sensor is detected;
- Ignition (configured Ignition Source) is off.

FMB001 exits sleep mode when if **ONE** of following conditions are true:

- Movement by movement sensor is detected;
- Ignition (configured Ignition Source) is turned on.

4.2.2 Deep Sleep mode

While in deep sleep mode, FMB001 sets GNSS receiver to sleep mode and turns off GSM/GPRS module (it is not possible to wake up device via SMS). Despite records with last known coordinate are being saved and send to AVL server (GSM/GPRS module is turned on to send data and after that it is turned off again), power usage is decreased to save vehicle's battery. Note, that power saving depends on two configurable parameters: send period and min. record saving period in "X on Stop Mode".

FMB001 can enter deep sleep mode if **ALL** of these conditions are met:

- FMB001 has to be configured to work in Deep Sleep mode;
- Device must be synchronized time with GNSS satellites;
- FMB001 has to be in „X on Stop Mode“ (Configured by Mode switch parameter);
- Movement by accelerometer is not detected;
- Ignition (Configured to be detected by Power Voltage, Ignition or Accelerometer) is off;
- Min. Record Saving Period (Data Acquisition Mode settings) must be bigger than Active Data Link Timeout parameter, that FMB001 could close GPRS link.
 - Send period (Data Acquisition Mode settings) minus Active Data Link Timeout must be more than 90 sec., that FMB001 could close GPRS link for at least 90 sec.
 - Sleep timeout is reached.

FMB001 exits deep sleep mode when if **ONE** of following conditions are true:

- Movement by accelerometer is detected;
- Ignition (Configured to be detected by Power Voltage, Ignition or Accelerometer) is turned on.

4.2.3 Online Sleep mode

In this mode device works as in Deep Sleep mode, but without turning off GSM network. GSM part stays powered, so this increases power consumption. In this mode, device should received/send SMS and make/receive calls. Also not closes GPRS context, if previously opened.

4.3 Virtual odometer

Virtual odometer is used to calculate traveled distance in FMB001 as a separate I/O element. When FMB001 detects movement, it starts counting distance using GNSS signal: every second it checks current location and calculates distance between current and previous point. It keeps adding these intervals until it is time to make a record, then FMB001 records its location

and adds odometer value, which is equal to the sum of all distances, measured every second. User can choose Odometer mode: 0 – Normal mode, or 1 – Continuous.

At Normal mode, when record is made, odometer resets to zero and distance calculation starts all over again.

Continuous odometer mode requires ignition (configured Ignition source) to be turned on. Odometer counts all distance calculations from records and sums them to one distance. Continuous odometer stops counting, when vehicle is at stop and ignition is turned off.

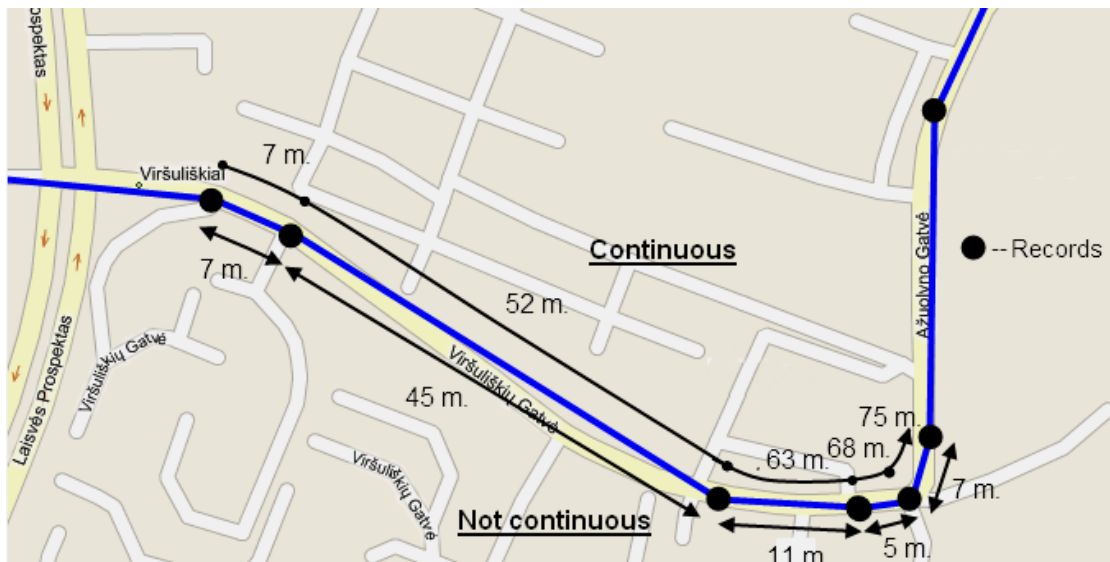

Figure 6 Odometer continuous and Not continuous distance counting parameter example

4.4 Features

Using available features can greatly increase FMB001 usability options.

4.4.1 Green Driving/Eco Driving Scenario.

Helps to prevent and inspect driver about harsh driving. Scenario continuously monitors: accelerating force, braking force and cornering angles.

To prevent generating false events, harsh acceleration and harsh braking is monitored only when following conditions are fulfilled:

- Ignition is ON (DIN1 = 1)
- Vehicle speed is equal or higher than 10km/h

Harsh cornering is monitored only when following conditions are fulfilled:

- Ignition is ON (DIN1 = 1)
- Vehicle speed is equal or higher than 30km/h

Eco Driving or Green Driving? Eco driving works depending on accelerometer data and Green driving uses GPS data.



Note: Green Driving and Eco Driving Scenarios are a factor on various cars and various drivers testing phase and can be subject to changes. Teltonika is constantly working on improvement of the functionality of the devices, and strongly recommends using the latest version of the firmware.

4.4.2 Over Speeding Scenario.

Helps to prevent from exceeding fixed speed and inspects driver if needed.

4.4.3 Excessive Idling

Informs you if your vehicle is stationary but engine is on for selected period of time to help you to save fuel

4.4.4 Jamming detection

Jamming detection shows when GSM signal jamming occurs.

4.4.5 Trip

Trip customizable feature enables user extended monitoring of performed trips (from engine start at present location to engine stop at arrived location), log their start and stop points, view driven total distance³. Event will be **generated (included into send records) only** when trip starts and finishes.



Note: Scenarios and Trip feature are activated only if DIN1=1 (ignition is on).

4.5 Accelerometer scenarios

4.5.1 Towing Detection

Towing detection scenario helps to inform driver about car departing. FMB001 generates event when car is being towed or raised, for example in case of vehicle evacuation.

FMB001 activates towing function when these conditions are met:

- Ignition (configured Ignition Source) is OFF
- Activation Timeout (set in Towing detection features) is reached

When Activation Timeout is reached and Ignition is still in OFF state, FMB001 monitors accelerometer data. If Acceleration or Angle value reaches configured threshold for configured Duration (in ms), check Ignition state. If Ignition is still OFF during configured "Ignition check after Event Timeout" time, then event is generated. If configured - sends sms event or makes a call.

Function will be reactivated after FMB001 again detects change of Ignition state from ON to OFF.

4.5.2 Unplug Detection

Unplug detection Scenario generates event when FMB001 is unplugged from OBD socket.

³ Continuous odometer – total driven distance, works only in TRIP mode. Continues distance is counted only for ONE trip. If trip is finished (stop point is detected), odometer resets to 0 (zero). Next trip will start counting from the beginning.

4.5.3 Crash Detection

If Crash detection is enabled, it monitors acceleration on each axis, if acceleration exceeds configured value for longer then configured duration, event with value "1" is generated.

4.5.3.1 Crash Trace operation

If trace is enabled FMB will collect acceleration data every 40 msec.

4.5.3.2 Bluetooth

Bluetooth can work in two modes - *slave* or *master*.

While working as *master* mode - Bluetooth can connect to defined "*hand free*" or "*OBDII*" system.

While working as *slave* mode - Bluetooth can accept incoming connection from external device.

5 CONFIGURATION

5.1 Configurator

New FMB001 module has default factory settings. Settings should be changed according to your application and your GSM operator information.

FMB001 configuration may be performed via SMS commands or configurator.

FMB001 has one user editable profile.

It can be configured to acquire and send data to server. If device is not able to send data to server, GSM is not available FMB001 will start storing records to flash memory. It is possible to store up to 122880 data records with 64mb SD memory card. It will send data later when GPRS is available again. Note that FMB001 can have memory full of records. In such case it will start deleting oldest records in order to save new ones. Sending all data records to server may take some time.

FMB001 configuration is performed via FMB001 Configurator program. Contact sales manager to get the latest FMB001 Configurator version. FMB001 configurator operates on Microsoft Windows OS and uses MS .Net Framework 3.5 or higher. Please ensure that MS .Net Framework 3.5 or later is installed on your PC before starting configurator. Latest MS .Net Framework version can be downloaded from official Microsoft web page.

Module configuration is performed over USB cable or BlueTooth connection. Configuration process starts from starting FMB001 Configurator program and then connecting to FMB001 device via Connect button located in Online menu part. FMB001 has one user editable profile, which can be loaded from device, and saved. User can also revert to default settings, by pressing Reset to defaults button. After any modification of configuration settings it has to be saved to FMB001 device, otherwise it will not be written to device.



Note: It is not recommended to downgrade firmware. We can't guarantee that all functions will be working correctly - it is possible that in old firmware versions there won't be some functions.

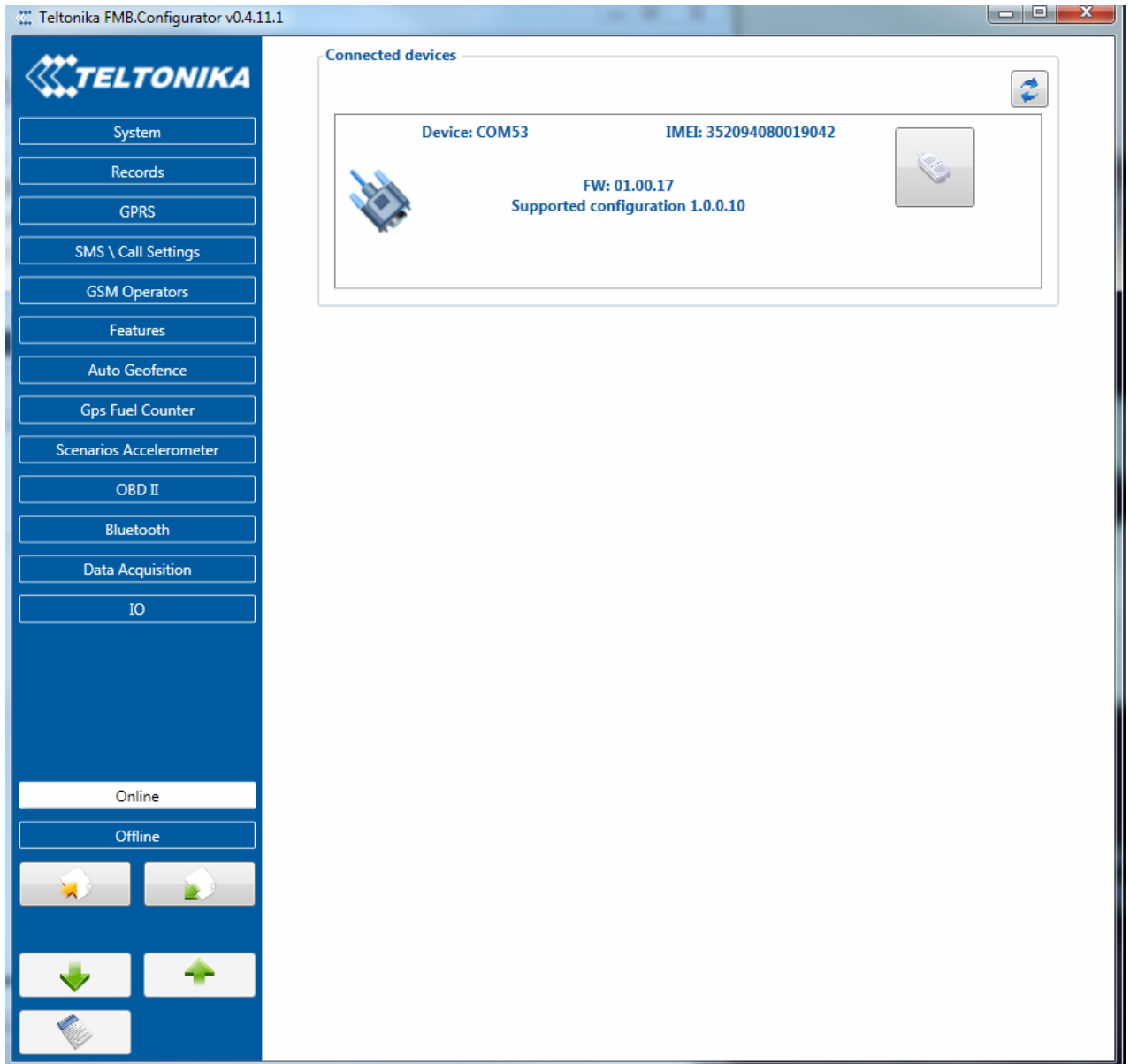

Figure 8 Configurator main window

Main Buttons description:

'Scan' – scans for available devices.

'Connect to device' – connects device.

'Store configuration to file' – saves configuration.

'Read configuration from file' – loads saved configuration.

'Read configuration' – loads configuration from device.

'Store configuration' – saves configuration to device.

Keyword SMS (GPRS) commands:

"setkey <oldkeyword> <newkeyword>" - Set new or change the keyword. Configuration should be not locked. Example:

New keyword (set):

<name>{space}<pass>{space}setkey{space}{space}{space}<newkeyword>

Change keyword (change):

<name>{space}<pass>{space}setkey{space}<oldkeyword>{space}<newkeyword>

"delkey <keyword>" - Deletes current keyword. Configuration keyword should be configured and not locked.

Example:

<name>{space}<pass>{space}setkey{space}<keyword>

Keyword configuration with TCP

Param ID 10 used for keyword configuration. Configuration should not be locked. Send empty if want delete the keyword, or not empty if want change/set

Param ID 10 config reading from SMS/GPRS forbidden.

5.1.1 System settings

System settings 9 configurable parameters:

1. Sleep settings, where user can choose sleep mode;
2. Ignition source, where user can choose between power voltage, digital input 1 and accelerometer ignition sources
3. Object Motion Detection Settings, where user can configure 3 ways how FMB001 will detect stopped movement, and change its working mode (for working modes, read section 5.2);
4. Static navigation settings, where user can turn static navigation on or off;
5. Records Settings, where user can enable or disable records when GPS is not available (no time synchronization);
6. GNSS source Settings, where user can choose satellite system.
7. LED indication, where user can turn on or off indication LEDs.
8. Battery charge mode, where user can choose when battery charger is turned on.



Functional purpose

Battery charge mode "On Need" - Enable battery charger any time when needed.
 "After Ignition ON" - Charger can be enabled after ignition is turned on, except if battery is fully charged or 10 minute timeout has not passed since device was turned on for faster FIX receiving.

9. Time synchronization mode, where you can choose how time synchronization is done. Possible values:
 - a) Disable (GPS only) – time is synchronized only from GNSS satellites
 - b) NITZ – time is synchronized from GNSS satellites or GSM operator (not all GSM operators support this functionality)
 - c) NTP – time is synchronized from GNSS satellites or NTP servers.
 - d) NITZ+NTP – time can be synchronized from GNSS satellites, GSM operator or NTP server

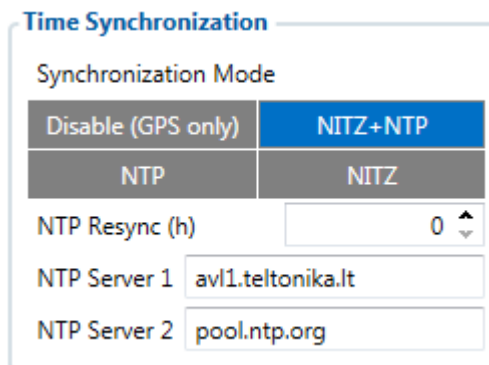

Figure 6

If necessary, you can configure your NTP servers and how often device should resynchronize time from NTP (NTP Resync parameter).

Table 5 Configuration parameters

Movement Source	Vehicle on Stop mode	Vehicle Moving mode
Ignition (recommended)	If ignition (DIN1) is logic low	If ignition (DIN1) is logic high
Movement (movement sensor)	Internal movement sensor does not detect movement	Internal movement sensor detects movement
GPS	GPS fix is available and vehicle speed is lower than 5 km/h	GPS fix is available and vehicle speed is higher than 5 km/h
	While GPS fix is unavailable, Object Motion Detection Settings are working like in Msensor mode	

Static Navigation Mode is a filter, which filters out track jumps when the object is stationary. If Static navigation filter is disabled, it will apply no changes on GPS data. If Static navigation filter is enabled, it will filter changes in GPS position if no movement is detected (depends on Object Motion Detection Settings). It allows filtering GPS jumps when object is parked (is not moving) and GPS position is still traced.

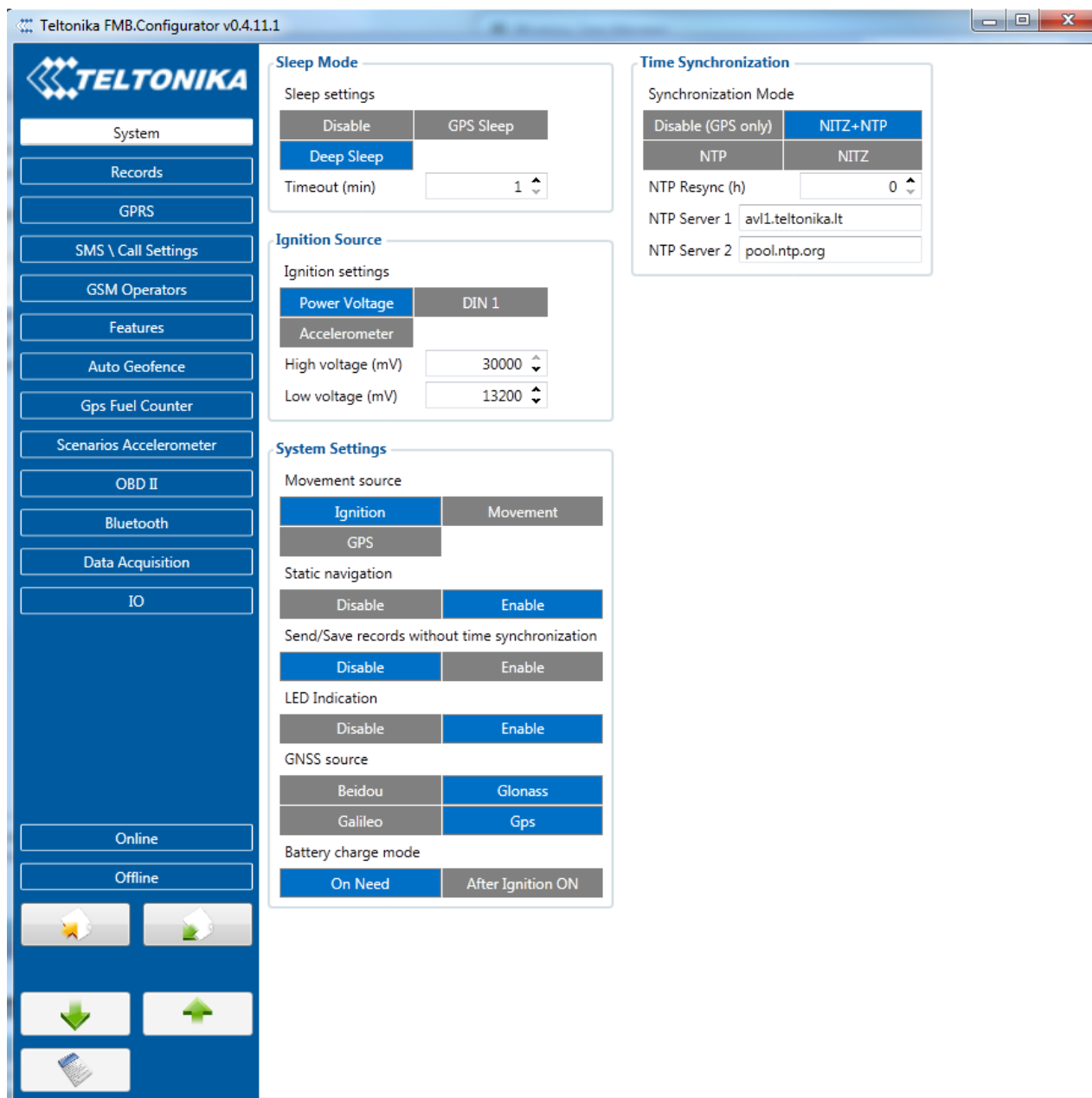

Figure 9 System settings configuration

In GNSS source Settings user can configure which GNSS system or systems to use.

User has choice to use only one system of GPS, Glonass, Galileo or Beidou. Also it is able to choose two or three systems together. One exception is that you can not combine Beidou and Glonass systems together.

List of configurable GNSS sources:

Beidou only	ID:01
Glonass only	ID:02
Galileo only	ID:04
Galileo+Beidou	ID:05
Galileo+Glonass	ID:06
Gps only	ID:08

GNSS source

Beidou	Glonass
Galileo	Gps

Example of a good configuration

Gps+Beidou	ID:09
Gos+Glonass	ID:10
Gps+Galileo	ID:12
Gps+Galileo+Beidou	ID:13
Gps+Galileo+Glonass	ID:14

List of **NON**–configurable GNSS sources:

- Glonass+Beidou
- Galileo+Glonass+Beidou
- Gps+Glonass+Beidou
- GPS+Galileo+Glonass+Beidou

GNSS source

Beidou	Glonass
Galileo	Gps

Example of a bad configuration

5.1.2 Records settings

Here user can modify if FMB001 device will send newest records first, meaning, that the most important thing is to know recent position of car, older records are being sent right after newest records arrive to AVL application.

Activate Data Link Timeout is used to set timeout of link between FMB001 and AVL application termination. If FMB001 has already sent all records it waits for new records before closing link. If new records are generated in the period of this timeout, and minimum count to send is reached, they are sent to AVL application. This option is useful when GSM operator charge for link activation.

Server Response Timeout is used to set time period waiting for response from server side.

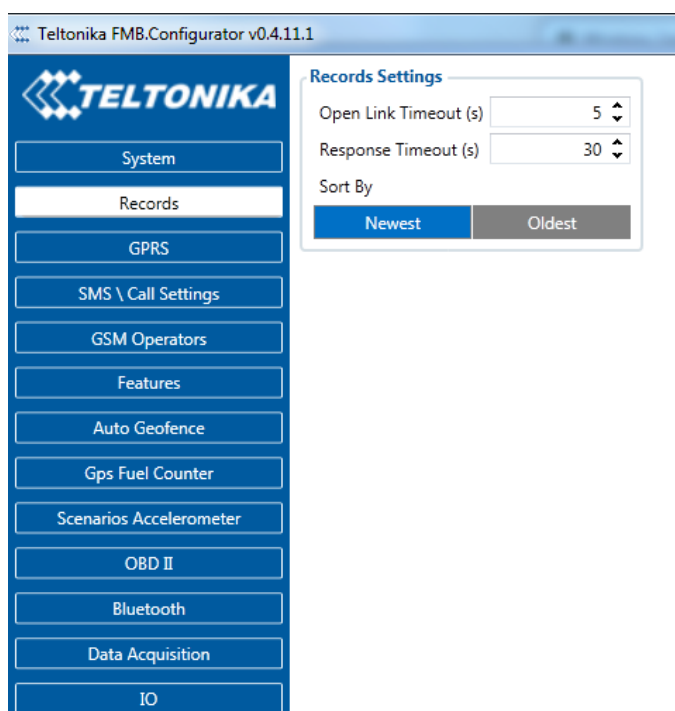

Figure 10 Records settings configuration

5.1.3 GSM settings, GPRS part

'GPRS' defines main parameters for FMB001: GSM operator APN and GPRS username and password (optional – depending on operator), destination server IP and port, and allows to set protocol used for data transfers – TCP or UDP.

Some operators use specific authentication for GPRS session – CHAP or PAP. If any of these is used, APN should be entered as ‘chap:<APN>’ or ‘pap:<APN>’. I.e. if operator is using APN ‘internet’ with CHAP authentication, it should be entered as ‘chap:internet’. Information about APN and authentication type should be provided by your GSM operator.

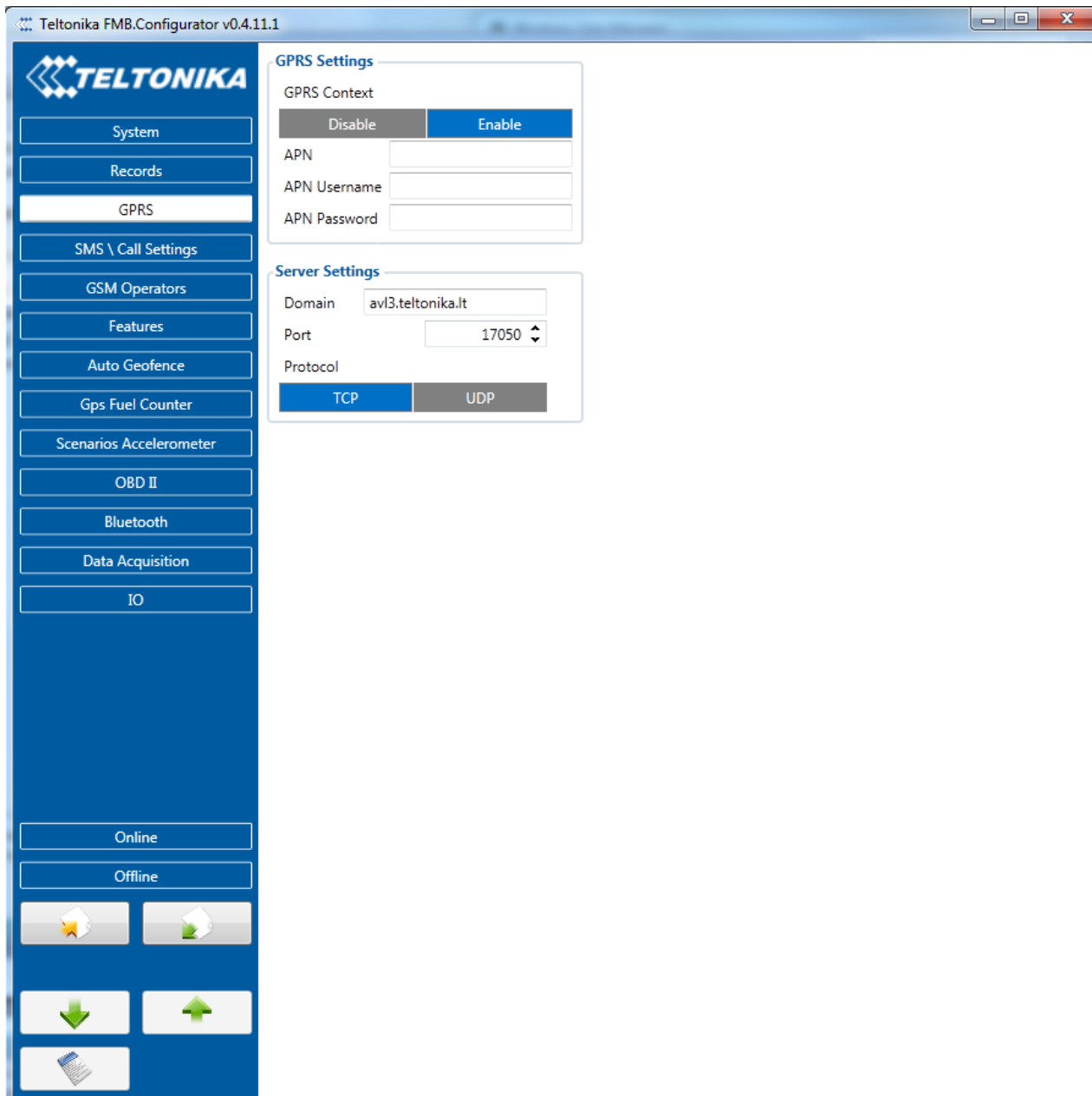

Figure 11 GPRS configuration

5.1.4 GSM settings, SMS part

Essential fields in ‘SMS’ part are ‘Login’ and ‘Password’. The login and password are used with every SMS sent to FMB001. If login and password are not set, in every SMS sent to FMB001 device two spaces before command have to be used (<space><space><command>).

Command structure with set login and password:

<login><space><password><space><command>, example: “asd 123 getgps”

Phone numbers have to be written in international standard, without using “+” or “00” signs in prefix. If no numbers are entered, configuration and sending commands over SMS are allowed from all GSM numbers.

SMS data sending settings – enable or disable **periodic** data and event SMS usage. This setting does not affect replies to SMS request messages – answers are always sent back to sender telephone number.

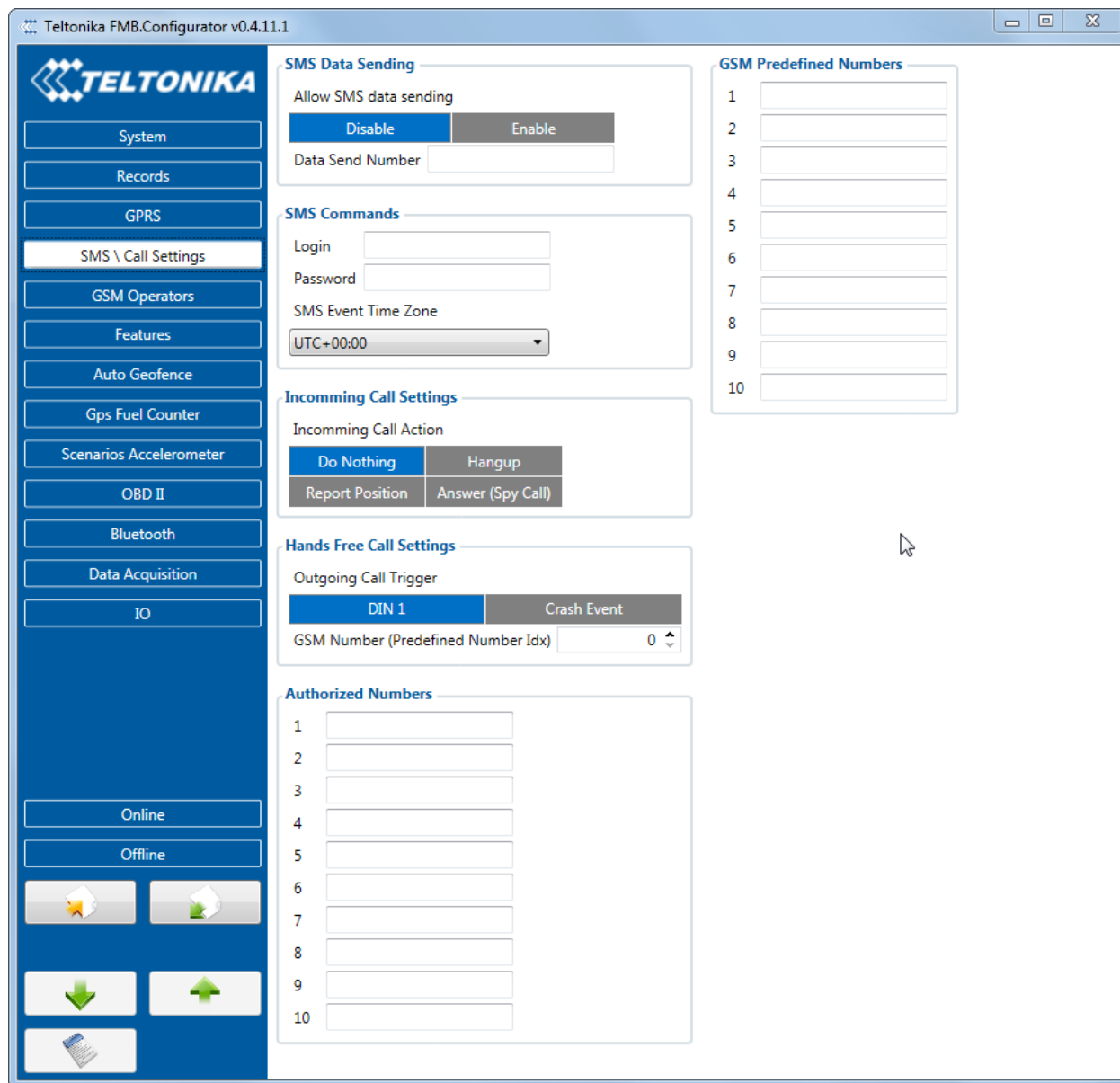

Figure 12 SMS configuration

Hands free call functionality

When FMBXX is connected to hands free headset it can call to user defined GSM numbers.

Hands Free Call Settings

Outgoing Call Trigger

DIN 1	Crash Event
-------	-------------

GSM Number (Predefined Number Idx)

Outgoing Call Trigger parameter determines which event will triggers call. FMBXX supports four different call triggers:

- None selected – disables call trigger functionality.
- DIN1 – first digital input event triggers call to user selected GSM number.
- Crash Event – crash event triggers call to user selected GSM number.
- DIN1 and Crash Event – both events triggers call to user selected GSM number.

SMS Event Time Zones

FMB001 works with synchronized GPS time which is UTC+0, with this option customer can configure his time zone and get SMS with correct time.



Note: Please do not set Data Send Number to some cell phone number, because it will not understand binary SMS. When sending a binary SMS to a phone number, which is a server phone number, the server can interpret and understand binary code, so the data can be read and you can view it on the server.



SMS login and password and authorized number list are used to protect FMB001 module from unauthorized access. Module accepts messages only from a list of authorized numbers and with proper module login and password. Numbers must be without “+” or “00” prefix. If no authorized numbers are entered, module accepts messages from all numbers.

SMS events

SMS events functionality allows FMB001 to send a configured SMS when an event is triggered. This event can be triggered by ever I/O element.

Then any of the I/O elements is triggered, FMB001 sends a configured SMS message to a defined phone number. If SMS events is activated, but there are no numbers defined in SMS events PreDefined Numbers list (figure 20), then the device will not send any messages.

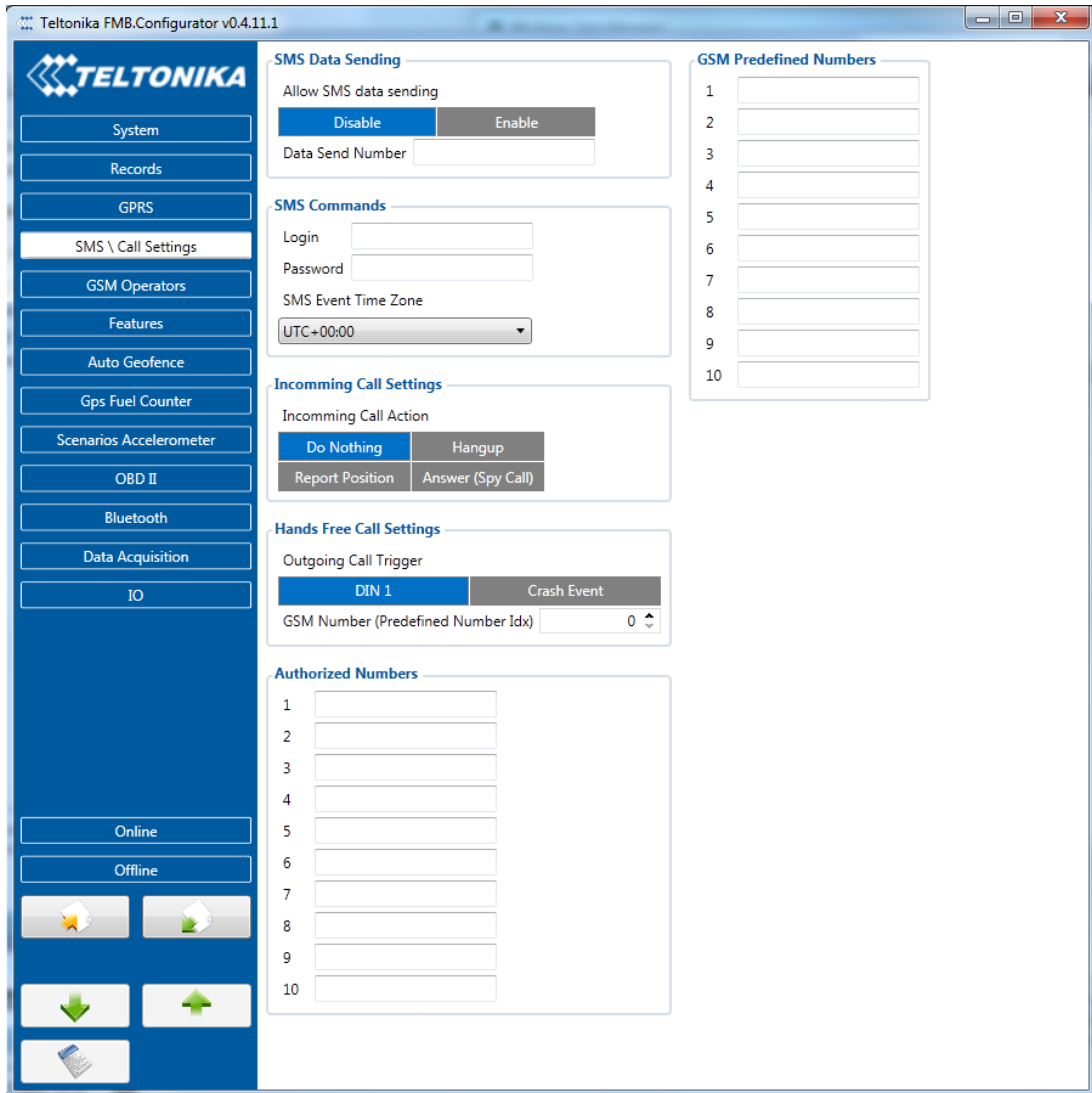

Figure 20 SMS Events PreDefined Numbers list

The sent SMS messages format is according to:

“Date Time EventText”

For example, if FMB001 is configured to send an SMS, when Ignition reaches High level, with priority High and configured to generate event on both, range enter and exit (figure 21), then the sent SMS is:

“2012/6/7 12:00:00 Ignition 1”

Input name	Priority				Low level	High level	Event only		Operand	Avg const	Send SMS to	SMS Text
Ignition	None	Low	High	Panic	0	1	Yes	No	On Both	10	12345678	Ignition 1
Movement	None	Low	High	Panic	0	0	Yes	No	On Change	1		
Data Mode	None	Low	High	Panic	0	0	Yes	No	On Change			
GSM Signal	None	Low	High	Panic	0	0	Yes	No	On Change	1		
Sleep Mode	None	Low	High	Panic	0	0	Yes	No	Monitoring			
GNSS Status	None	Low	High	Panic	0	0	Yes	No	On Exit			
GNSS PDOP	None	Low	High	Panic	0	0	Yes	No	Monitoring	10		
GNSS HDOP	None	Low	High	Panic	0	0	Yes	No	Monitoring	10		
External Voltage	None	Low	High	Panic	0	1000	Yes	No	On Delta Change	10		
Speed	None	Low	High	Panic	0	0	Yes	No	Monitoring	1		
GSM CellID	None	Low	High	Panic	0	0	Yes	No	Monitoring			
GSM Area Code	None	Low	High	Panic	0	0	Yes	No	Monitoring			
Battery Voltage	None	Low	High	Panic	0	0	Yes	No	Monitoring	10		
Battery Current	None	Low	High	Panic	0	0	Yes	No	Monitoring	10		
Active GSM Operator	None	Low	High	Panic	0	0	Yes	No	On Change			
Trip Odometer	None	Low	High	Panic	0	0	Yes	No	Monitoring			
Total Odometer	None	Low	High	Panic	0	0	Yes	No	Monitoring			
Digital Input 1	None	Low	High	Panic	0	0	Yes	No	On Exit	1		
Fuel Used GPS	None	Low	High	Panic	0	0	Yes	No	Monitoring	1		
Fuel Rate GPS	None	Low	High	Panic	0	0	Yes	No	Monitoring	1		
Axis X	None	Low	High	Panic	0	0	Yes	No	Monitoring	1		
Axis Y	None	Low	High	Panic	0	0	Yes	No	Monitoring	1		
Axis Z	None	Low	High	Panic	0	0	Yes	No	Monitoring	1		
Number Of DTC	None	Low	High	Panic	0	0	Yes	No	Monitoring			
Engine Load	None	Low	High	Panic	0	0	Yes	No	Monitoring			
Coolant Temperature	None	Low	High	Panic	0	0	Yes	No	Monitoring			
Short Fuel Trim	None	Low	High	Panic	0	0	Yes	No	Monitoring			
Fuel Pressure	None	Low	High	Panic	0	0	Yes	No	Monitoring			
Intake MAP	None	Low	High	Panic	0	0	Yes	No	Monitoring			
Engine RPM	None	Low	High	Panic	0	0	Yes	No	Monitoring			

Figure 21 Configured Ignition SMS event

The SMS Text field can be altered and any text can be entered. Maximum message length is 90 symbols (numbers, letters and symbols in ASCII, except for comma “,”).

ATTENTION!



If FMB001 is in Deep Sleep mode and SMS event occurs with LOW priority (which does not wake up FMB001), then the device does not send the message. It is saved in device memory until it wakes up from Deep Sleep mode and GSM modem starts working normally. After it wakes up, all the messages that are saved in memory will be sent, but keep in mind that only 10 messages can be saved in memory – all other messages will not be saved, until there is room in device memory.

5.1.5 GSM settings, Operator list

Operators list – FMB001 can work in different modes (use different settings) according to the operator list defined. Operator list is used for Data Acquisition Mode switching (see chapter 5.2 Data Acquisition Mode settings for more details). Modes are changed based on GSM operator FMB001 is connected to.

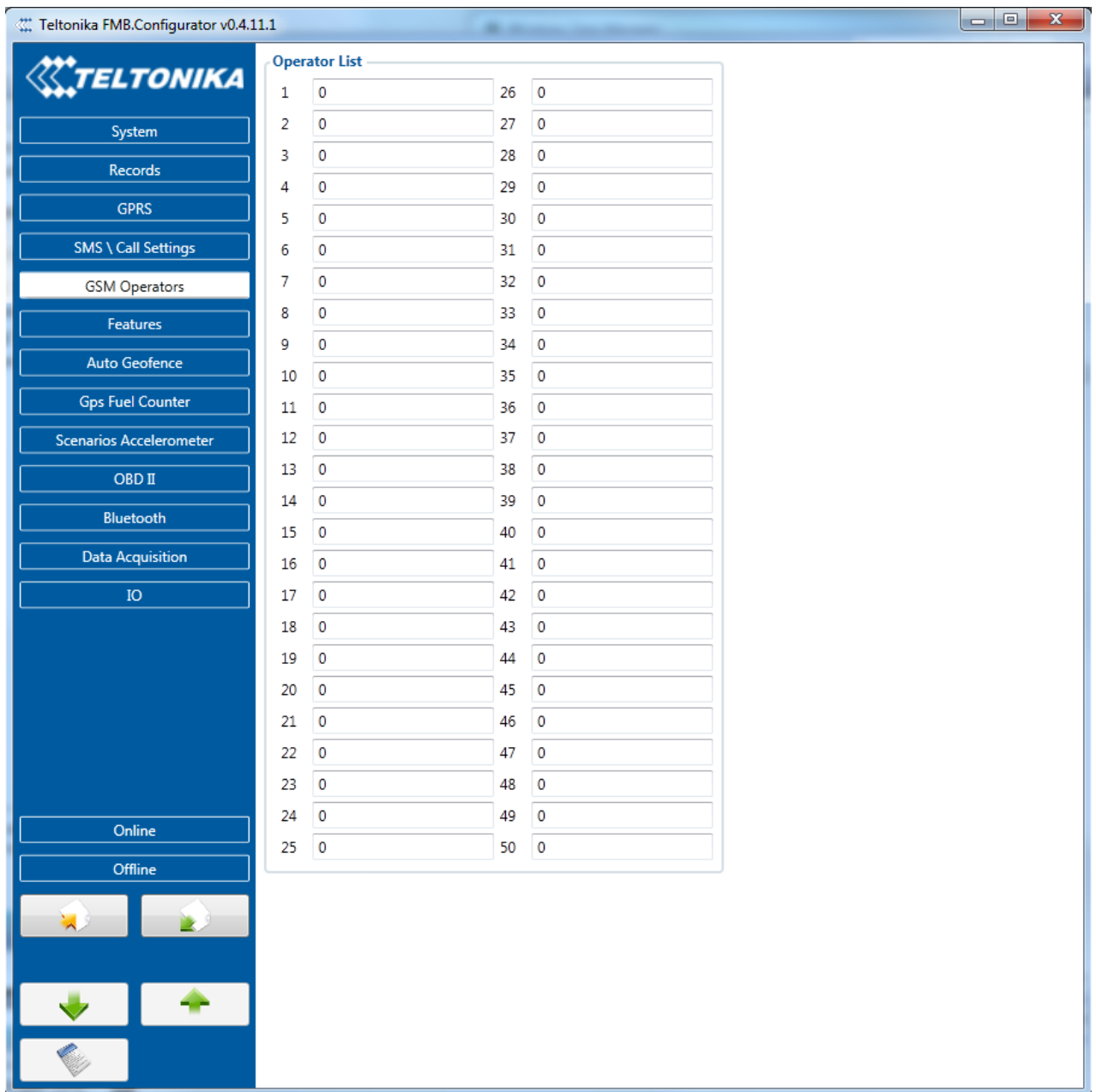

Figure 13 Operator list configuration

If operator list is left empty, it will allow using GPRS to any GSM operator. Please note that FMB001 will work in **Unknown mode only** (make sure it is configured to allow data sending – GPRS context is enabled).

5.2 Features settings

In Features window five different scenarios are available.

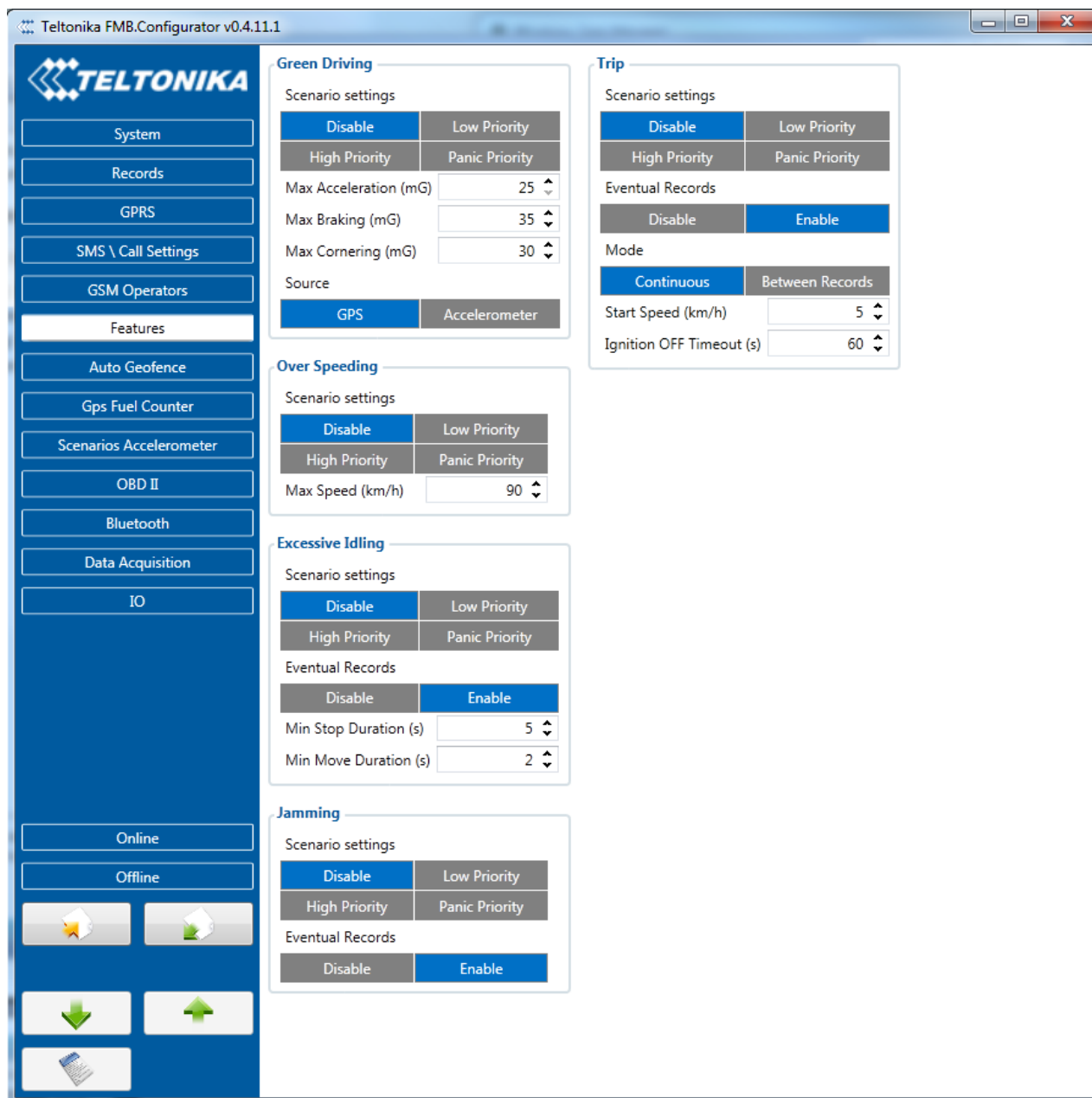

Figure 16 Scenarios configuration

1. Eco/Green Driving

Scenario is activated, when vehicle exceeds on of Max. Acceleration, Max Braking or Max Cornering parameters value. You can configure Max. Acceleration and Max. Braking parameters in mG (miliG) units and Max. Cornering parameter in rad/s units and the source of data. Scenario is activated until current Acceleration, Braking or Cornering value decreases below parameter value.

Parameters used with ECO driving/Green driving functionality.

Green Driving

Scenario settings

Disable	Low Priority
High Priority	Panic Priority

Max Acceleration (mG)

Max Braking (mG)

Max Cornering (mG)

Source

GPS	Accelerometer
-----	---------------

ECO driving/Green driving configuration parameters

ECO driving/Green driving configuration parameter name	Description
ECO driving/Green driving	Enable/Disable ECO driving/Green driving functionality
Max Acceleration Force	Value which can be reached while accelerating without triggering harsh acceleration event.
Max Braking Force	Value which can be reached while braking without triggering harsh braking event.
Max Cornering Force	Value which can be reached while cornering without triggering harsh cornering event.

Data Output.

ECO driving/Green driving functionality generates events on three cases. If vehicles:

- Acceleration exceeds defined parameter value
- Deceleration (braking) exceeds defined value
- Cornering force exceeds defined value

Program continuously monitors and process data from accelerometer than decides whether harsh event is detected or not. If any of three cases are satisfied event is generated. Record is saved and sent to server (FMB001 must be configured properly). Event value is multiplied by 10 before sending/saving record to get more precision when displaying **data***.

Digital output No.1 is activated for a period of time to warn driver. Output on-time should/can be configured separately for each case.

***Example.** If acceleration harsh event of 3.55 m/s² detected. Record with value 3.55*10 = 35.5 ≈ 36 will be saved ant sent to server.

Auto Calibaration

1. Vehicle stopped
2. Road is straight
3. Send SMS "auto_calibrate"
4. Acceleraate to > 30 km/h for 5 sec.

5. FMB will send response when calibration is success.

Calibration is saved to Internal Flash, after restart should be the same

To check autocalibration status send: position_info

To zero out accelerometer axis SMS: "calibrate", can be used, vehicle speed must be 0 km/h.

2. Over Speeding

Scenario is activated, when vehicle speed exceeds parameter value. Scenario is activated until current speed decreases below parameter value.

3. Excessive Idling

Scenario is activated, when vehicle stops for specific amount of time. You can configure time it takes to turn on this scenario (Time to Stopped). Scenario is activated until vehicle starts moving and keeps moving for amount of time that is configured. You can configure time it takes to turn OFF this scenario (Time to Stopped).

4. Jamming

Scenario is activated(event sent to server), when jamming is detected.

5. Trip

Scenario is activated, when ignition is on and movement is detected. Scenario calculates distance user has moved.

5.2.1 Trip settings

Trip scenario offers user to configure Trip feature.

Start Speed – GPS speed has to be greater than the specified Start Speed in order to detect Trip Start.

Ignition Off Timeout – timeout to wait if ignition was off, to detect Trip stop.

Continuous distance counting – Not or Continuous can be chosen. For this feature I/O Odometer must be enabled.

If I/O Odometer is enabled and Continuous distance counting variable (Mode) is set to Continuous, **Trip distance** is going to be counted continuously (**from Trip start to Trip stop**). This value is written to I/O Odometer value field. When Trip is over and next Trip begins, Odometer value is reset to zero. When the next trip starts counting continuously starts from the beginning again.

If I/O Odometer is enabled and Continuous Distance Counting variable (Mode) is set "Between Records", then the distance is going to be counted only between every record made. This value is written to I/O Odometer value field and reset to zero every new record until Trip stops. If later all Odometer values are summed up manually, the user gets the distance driven during the whole period of the Trip.

Trip

Scenario settings

Disable	Low Priority
High Priority	Panic Priority

Eventual Records

Disable	Enable
---------	--------

Mode

Continuous	Between Records
------------	-----------------

Start Speed (km/h)

Ignition OFF Timeout (s)

Figure 17 Trip configuration

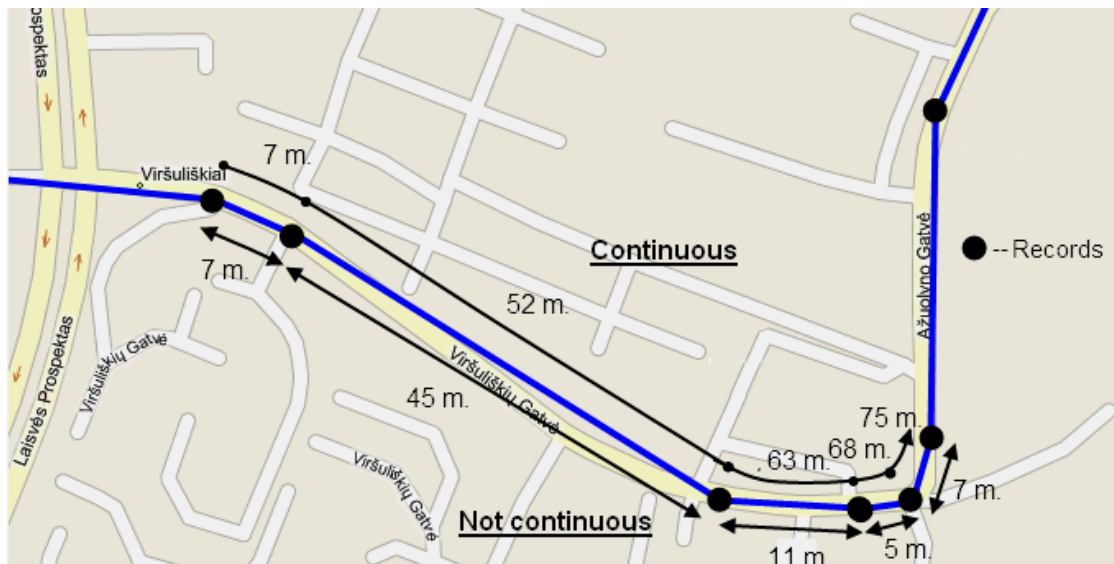

Figure 18 Trip continuous distance counting parameter example

5.2.2 AutoGeofencing settings

AutoGeofence – the last known position after movement = off. If your car's being taken away – you can be notified. The shape and size of the geofence zones are parameters. It is possibility to state whether entering in or out of the geofence triggers an asynchronous message.

AutoGeofencing option can be configured by following parameters visible in figure 19 below.

Activation TMO – Time period before Geofence is activated after vehicle stops.

Deactivate By:

Ignition – If ignition becomes high it will disable AutoGeofence Zone;

Power Voltage – if power voltage enters entered value it will disable AutoGeofence Zone.

Digital input 1 – if digital input is triggered it will disable AutoGeofence Zone.

- Feature – Priority of generated event, which will be applied to saved record.
- Enter Event – Event generation on Geofence entrance.
- Exit Event – Event generation on Geofence exit.
- On Both - Event generation on Geofence entrance Or exit
- Eventual Records – Enable or Disable Eventual Records functionality.

Note that AutoGeofencing does not require entering coordinates, instead it requires GPS visibility. If vehicle stopped and activation timeout has passed, an AutoGeofence will be created around vehicle's last position with set Radius value.

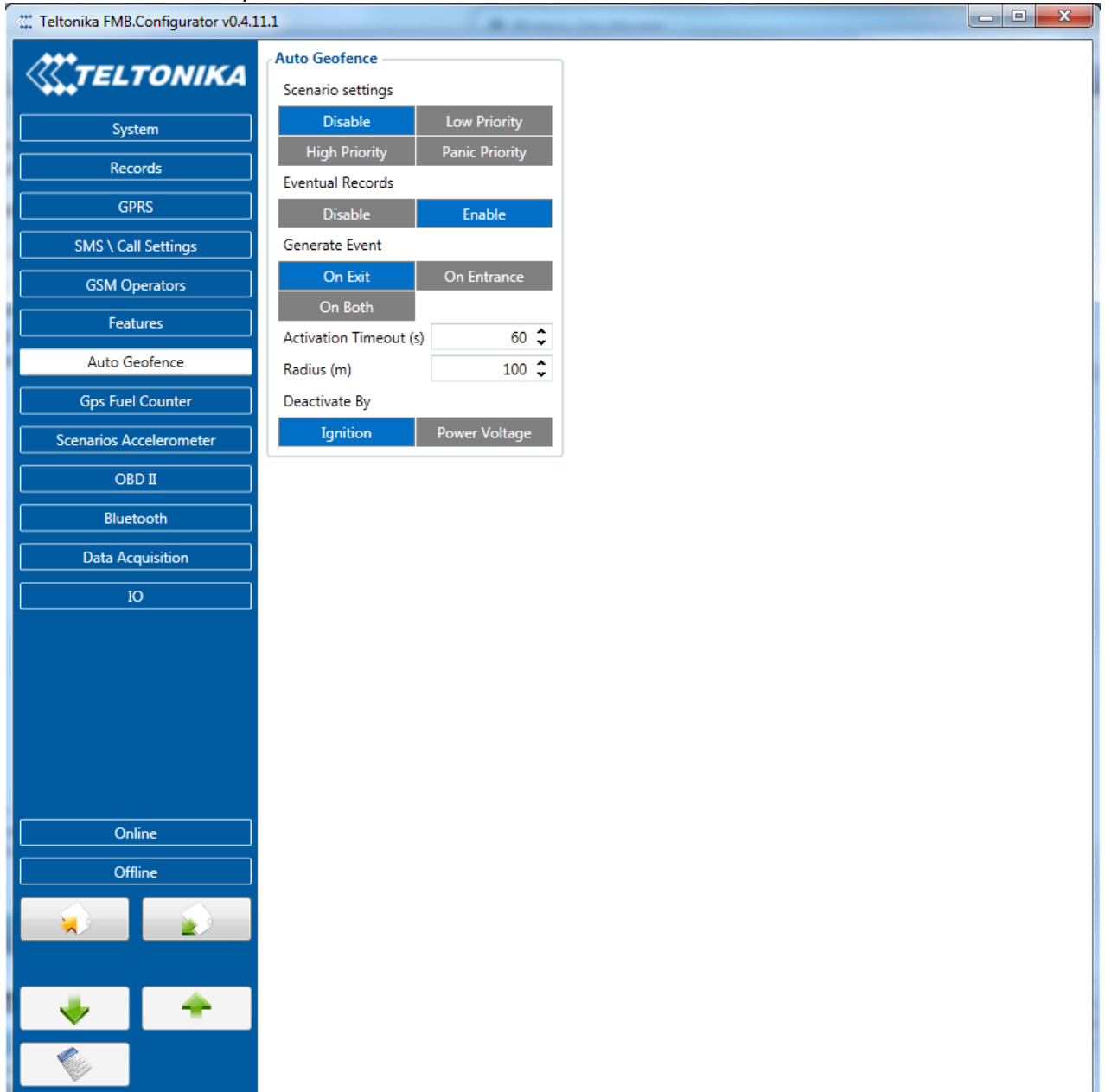

Figure 19 Geofence configuration

5.2.3 GPS Fuel Counter

Configuration of Fuel Consumption (Figure 7)

1. To configure these parameters use fuel consumption data, which is stated in your car technical documentation. By default speeds for this fuel consumption norms are: City – 30 km/h, Average – 60 km/h, Highway - 90 km/h. If you want, you can change it.

2. When speed is higher than highway speed, FMB001 adds highway fuel consumption $x\%$ of highway fuel consumption every y km/h, by default FMB001 adds 20% every 50 km/h. It means that fuel consumption is $(1.2 * \text{Highway Fuel Consumption})$ on 140 km/h speed, $(1.4 * \text{Highway Fuel Consumption})$ on 190 km/h speed.

3. Correction coefficient is used for correction of every fuel consumption value which is sent to server (Used Fuel * Correction coefficient). By default it is 1, min 0.01 and max 2. For example when correction coefficient is 1 and FMB001 calculates that used fuel for 35 m distance is 20 ml, sent value will be 20 ml; if correction coefficient is 1.2, sent value will be $20 * 1.2 = 24$ ml.

4. Fuel consumption on idling is used to calculate fuel consumption when ignition is on, but vehicle speed is 0 km/h. By default it is 1 l/h, min 0 and max 5 l/h. Almost in all diesel cars this parameter is less than 1.0 l/h. In gasoline cars this parameter is about 1.5 – 2.0 l/h.

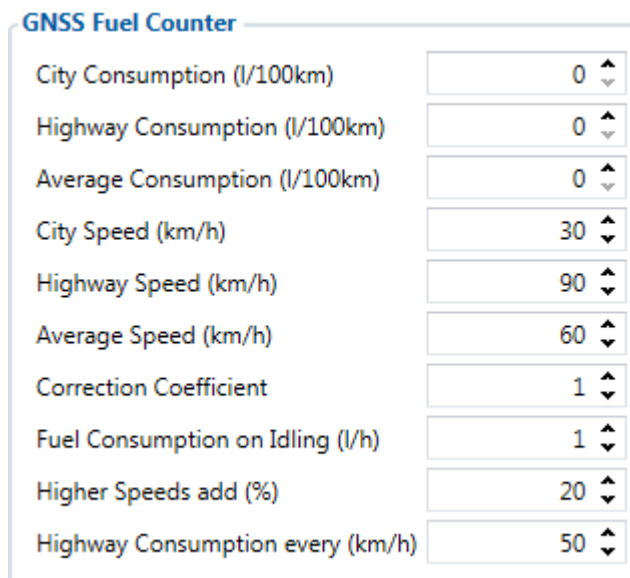

GNSS Fuel Counter	
City Consumption (l/100km)	0
Highway Consumption (l/100km)	0
Average Consumption (l/100km)	0
City Speed (km/h)	30
Highway Speed (km/h)	90
Average Speed (km/h)	60
Correction Coefficient	1
Fuel Consumption on Idling (l/h)	1
Higher Speeds add (%)	20
Highway Consumption every (km/h)	50

Figure 7 GPS fuel counter settings

5.2.4 Scenarios Accelerometer

Towing detection

FMB001 activates towing function when these conditions are met:

- Ignition (configured Ignition Source) is OFF
- Activation Timeout (set in Towing detection features) is reached

When Activation Timeout is reached and Ignition is still in OFF state, FMB001 monitors accelerometer data. If Acceleration or Angle value reaches configured threshold for configured Duration (in ms), check Ignition state. If Ignition is still OFF during configured "Ignition check after Event Timeout" time, then event is generated. If configured - sends sms event or makes a call. Function will be reactivated after FMB001 again detects change of Ignition state from ON to OFF.

Towing Detection

Scenario settings

Disable	Low Priority
High Priority	Panic Priority

Eventual Records

Disable	Enable
---------	---------------

Activation Timeout (min)

Event Timeout (s)

Make Call (Sms Event Number ID)

Treshold (mg)

Angle (deg)

Duration (ms)

Figure 8 Towing detection configuration

Activation timeout – Activation timeout is time after which FMB001 turns ON Towing detection function if other requirement is met (Ignition OFF state detected). It is measured in minutes.

Ignition check after event – defines time period (in seconds) to check ignition state when Acceleration or Angle value reach. If towing event is generated during this time period, it is skipped. It allows to filter out redundant towing events while entering the car.

Make Call to – if function enabled makes call to specified phone number (configured in pre defined numbers)

Acceleration, Angle – values used to detect towing when ignition is OFF

Duration – defines time period to check Acceleration, Angle values.

Unplug Detection

Eventual event will be generated when FMB001 is unplugged from OBD socket.

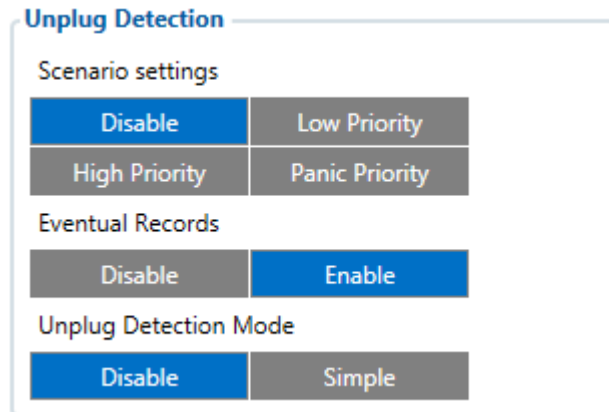

Figure 9 Unplug detection

Crash detection

Crash Detection functionality can be set according to these settings:

- Threshold (mg)
- Duration (ms)

If accident happens and FMB001 detects acceleration value higher than set threshold value during set time period, then device will generate an event. Threshold and duration values are set depending of accident power which you want to detect. FMB001 can detect a slight tapping on the device (Threshold=100mg, Duration=1ms) or can detect severe accident (Threshold=4000mg, Duration=5ms)..

Crash Trace operation

If trace is enabled FMB will collect acceleration data every 40 msec. Buffer is big enough to hold data for 5 seconds and on Crash Event detection, records will be generated from this buffer, following these conditions:

- Every second
- Acceleration changed more then > 50mG

Data will be collected and records generated 5 seconds after the event using the same conditions.

Every generated record will have accelerometer X Y Z values included. Each record will have accurate timestamps in milliseconds (for detailed crash trace record structure refer to FMB001 protocol document).

Usually between 20 to 30 records is generated on crash event detection.

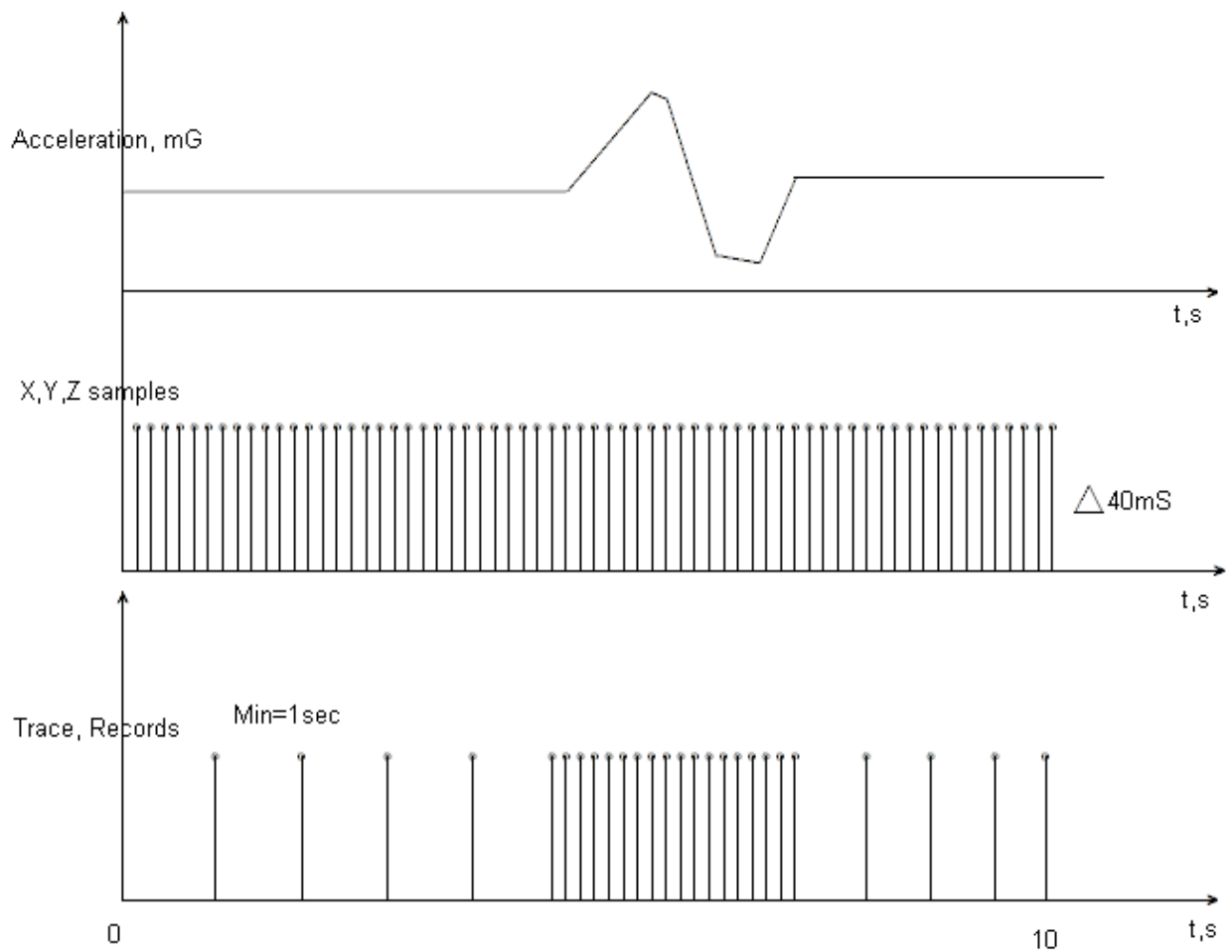
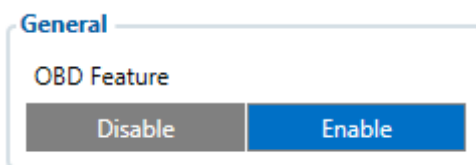

Figure 10 Example of Crash Trace logic

5.2.5 OBD II



Disable/Enable OBD II data reading.

5.2.6 Bluetooth

General

General

BT Radio

Disable	Enable (hidden)
Enable (visible)	

Local Name

Local PIN

Security Mode

PIN only	PIN + MAC list
MAC list only	None

Figure 11 General Bluetooth settings

BT Radio determines state determines Bluetooth status, possible values:

- a) Disable – Bluetooth is off;
- b) Enable (hidden) – Bluetooth is on, device automatically connects to defined MAC, but is invisible for external devices which want to pair with it.
- c) Enable (visible) – Bluetooth is on and visible for external devices.

Local name can be set according to your needs. If this field is empty, name will be automatically generated:

FMBxx_<imei last chars>

Local PIN - PIN code which will be used when external device will try to pair with FMB001.

NOTE: FMBXX supports ONE connection at a time.

Security mode possible options:

- a) PIN only – only pin is used when external device tries to connect to FMB001.
- b) PIN+MAC list – PIN is used, also external device’s MAC address needs to be in Authorized MAC list
- c) MAC list only – connection to FMB001 is possible only if external device MAC is in Authorized MAC list.
- d) None – no security enabled.

Auto Connect to External Device

Auto Connect to External Device

Connection Mode

None	Hands Free
------	------------

External MAC

External Name

External PIN

Figure 12 Auto connection to external devices

Here you can enter details of external Bluetooth headset for hands free communication.

External MAC – MAC of your Bluetooth headset.

External Name – Bluetooth name of you

NOTE: FMBXX supports ONE connection at a time.



Figure 13 MAC list

Figure 13 shows list of Authorized MAC addresses which are allowed to connect to FMB001. If list is empty, any external device can connect to FMB001.

5.2.6.1 Connecting to device via Bluetooth

When FMB device starts, automatically Bluetooth is ON too. Take your mobile phone, go to settings>Bluetooth and turn it on. Scan for near by devices, find you device in list, distinguish device by last IMEI numbers on device module. Press pair, wait until device will ask to enter pairing password, type: 5555. Paired device will show up in paired device list. Now download from play store/app store terminal for Bluetooth. E.g. BlueTerm. Run app, click find>connect to your paired device. Now we need to send command to FMB001 through Bluetooth terminal, type: .log:1

Device will respond Debug enabled and FMB001 log will show up. Do not forget to start save log file to mobile phone.

5.2.6.2 How to connect Bluetooth Hands Free adapter to FMB device

Bluetooth settings configuration

These are instructions how to easily prepare Bluetooth Hands Free device connection to FMB device. First we need to configure FMB device Bluetooth settings for proper connection to this hands-free unit. These are required steps:

1. Connect FMB device to PC using USB cable.
2. Launch **FMB Configurator** and connect to device as shown in **Figure 1** below.



Figure 1. FMB configurator connected devices window

3. After successful connection to device press **“Load from device”** button to load device current configuration visible at **Figure 2.1**

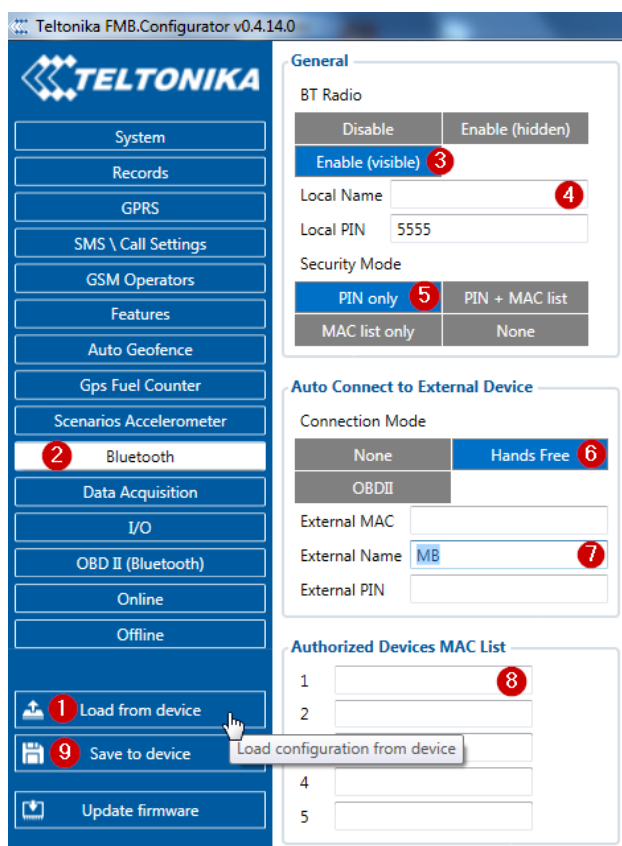

Figure 2.1 Load configuration from device; **2.2** Bluetooth settings; **2.3** Enable Bluetooth; **2.4** Bluetooth local name; **2.5** Bluetooth security mode **2.6** Hands Free connection mode; **2.7** External Bluetooth device name; **2.8** Authorized Devices MAC List; **2.9** Save device configuration

4. When device configuration is loaded press **„Bluetooth“** settings (**Figure 2.2**).
5. Turn on BT Radio by pressing **„Enable (visible)“** (**Figure 2.3**). You could leave **“Local name”** (**Figure 2.4**) box empty (then device name will automatically be **“FMBxx_last 7 imei digits”**) or type your own name.
6. Set Security Mode (**Figure 2.5**) to **“PIN only”** or **“None”** (you could select **“PIN + MAC list”** or **“MAC list only”** security mode but in this case you need to type external device MAC address in **“Authorized Devices MAC List”** (**Figure 2.8**).
7. Set connection mode to **“Hands Free”** (**Figure 2.6**).

8. Set „**External Name**“ as your Hands Free device name for proper device identification and connection to it. In this example Hands Free headset name is „MBH10“ but at least 2 characters are needed to recognize it and connect to it. For better and faster adapter identification in network you could enter a full device name. You could check your Hands Free adapter Bluetooth name by scanning nearby Bluetooth devices using mobile phone or computer with Bluetooth adapter.
9. Go to “**SMS \ Call Settings**” in left menu and set “**Incomming Call Action**” to “**Do Nothing**” visible at **Figure 3**.

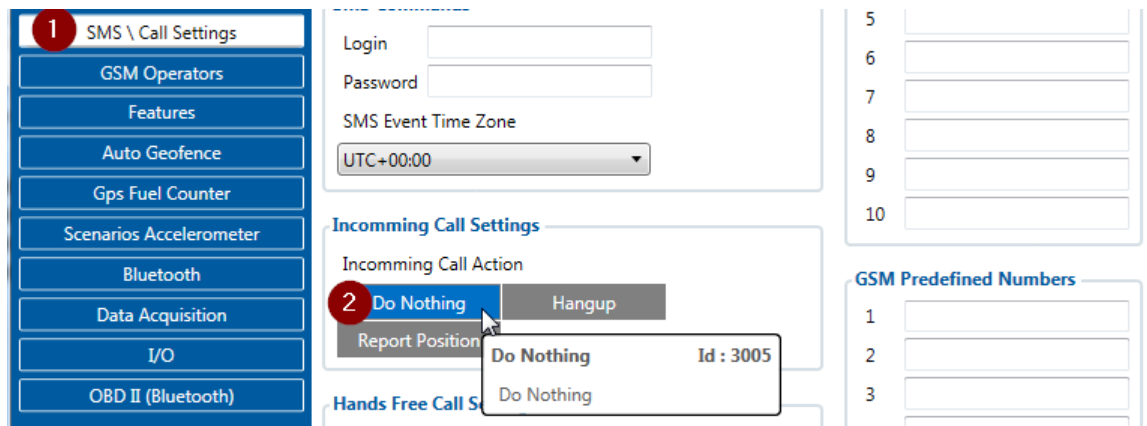

Figure 3. Incomming Call Action settings.

10. After all these steps press „**Save to device**“ to save configuration (**Figure 2.9**).
11. Now you can disconnect FMB device from a PC or stay connected if you want to make further changes to configuration.

Connecting Bluetooth Hands Free adapter

After this configuration you could connect your Hands Free device to FMB device. Turn on Hands Free device then turn on its Bluetooth connection for pairing following your model instructions⁴. Hands Free adapter should make a special sound in ear from speaker or its led identification should change to inform about successful connection⁵. To check if adapter is successfully connected, call to FMB device, Hands Free device should start ringing. If you later restart FMB device it will automatically connect to this adapter.

5.2.6.3 Device’s log using your mobile phone.

When FMB device starts, automatically Bluetooth is ON too. Take your mobile phone, go to settings>Bluetooth and turn it on. Scan for near a by devices, find you device in list, distinguish device by last IMEI numbers on device module. Press pair, wait until device will ask to enter pairing password, type: 5555. Paired device will show up in paired device list. Now download from play store/app store terminal for Bluetooth. E.g BlueTerm. Run app, click find>connect to your paired device. Now we need to send command to FMB0XX through Bluetooth terminal, type: .log:1

⁴ Hands Free device Bluetooth connection pairing instructions depends on specific model.

⁵ Hands Free device notification about paired Bluetooth connection depends on specific model.

Device will respond Debug enabled and FMB0XX log will show up. Do not forget to start save log file to mobile phone.

Device debug over Android smartphone

1. Scan for visible BT devices using your Android smartphone and connect to your FMB device.

Default FMB BT name: ***FMBxx_last_7_imei_digits***

Default PIN code: **5555**

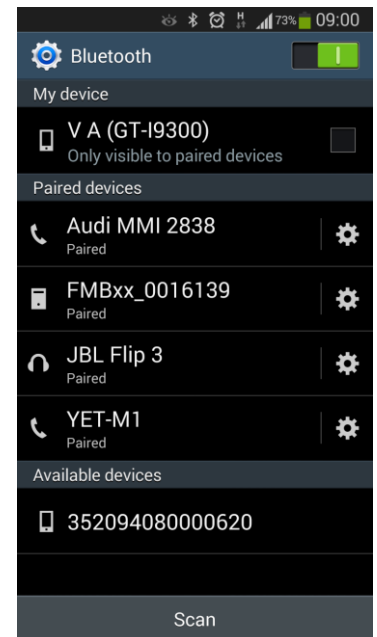

2. Download "Bluetooth Terminal" application. You can use link or QR code shown here:

<https://play.google.com/store/apps/details?id=com.hatf1abs.bt>



- Run Bluetooth Terminal. In menu press “Connect” button and select paired FMB device. To start log check CR and enter the command in terminal: **.log:1**

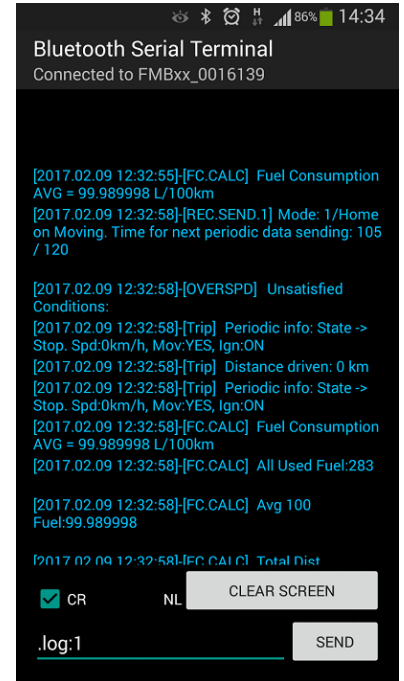

- Wait ~10 minutes and press “Save” button in menu. You will find saved log file in device folder (My Files/BluetoothTerminal), select log files and press button Share via Email and send them to the Teltonika support.

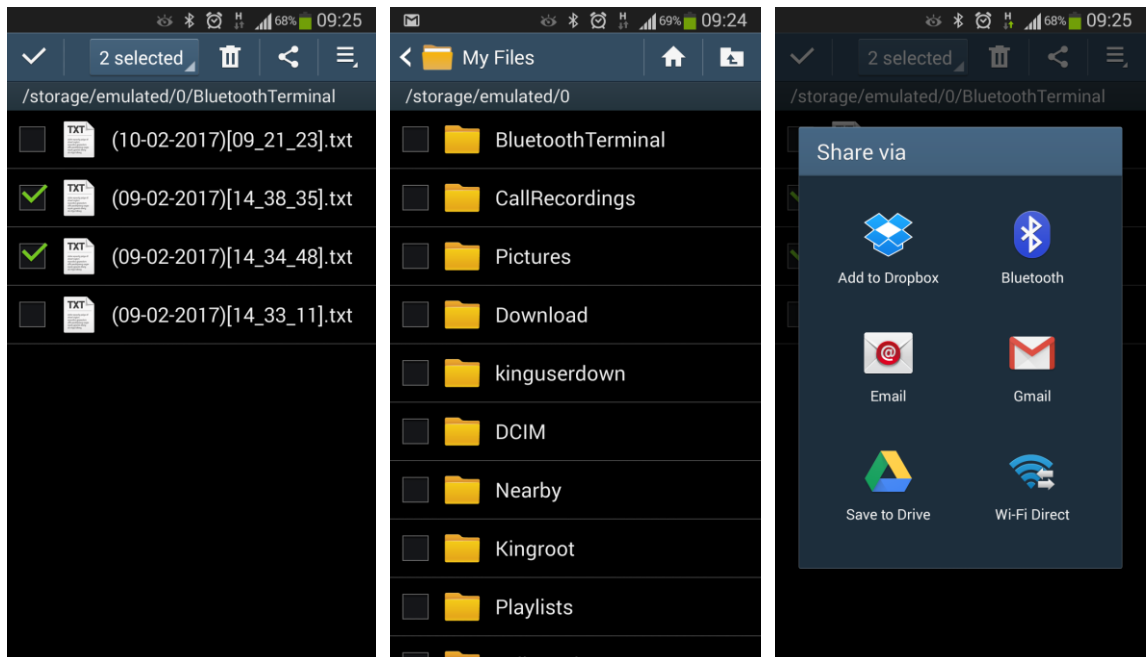

In order to pair FMB device with Android smartphone, make sure that BT radio is enabled (visible) in device configuration. It can be checked via SMS command too:

getparam 800

The answer has to be 2, which means “Enabled and visible”.

General	
BT Radio	
Disable	Enable (hidden)
Enable (visible)	
Local Name	FMB9_441
Local PIN	5555
Security Mode	
PIN only	PIN + MAC list
MAC list only	None

5.2.6.4 How to connect OBD II Bluetooth Dongle to FMB device



Note: Unfortunately it is not possible to do the same on iPhone, because there is no native SPP Bluetooth profile support in iPhone.

Bluetooth settings configuration

These are instructions how to easily prepare Bluetooth Dongle connection to FMB device. First we need to configure FMB device Bluetooth settings for proper connection to this unit. These are required steps:

1. Connect FMB device to PC using USB cable.
2. Launch **FMB Configurator** and connect to device as shown in **Figure 1** below.



Figure 1. FMB configurator connected devices window

3. After successful connection to device press “**Load from device**” button to load device current configuration visible at **Figure 2.1**

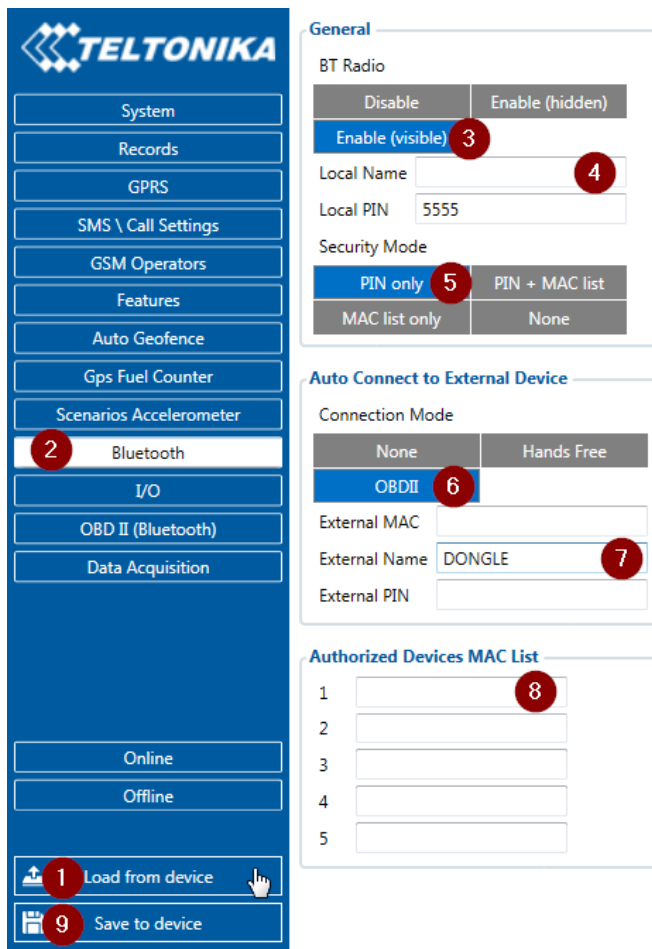

Figure 2.1 Load configuration from device; **2.2** Bluetooth settings; **2.3** Enable Bluetooth; **2.4** Bluetooth local name; **2.5** Bluetooth security mode **2.6** OBD II connection mode; **2.7** External OBD II Bluetooth device name; **2.8** Authorized Devices MAC List; **2.9** Save device configuration

4. When device configuration is loaded press „**Bluetooth**“ settings (**Figure 2.2**).
5. Turn on BT Radio by pressing „**Enable (visible)**“ (**Figure 2.3**). You could leave “**Local name**” (**Figure 2.4**) box empty (then device name will automatically be “FMBxx_last 7 IMEI digits”) or type your own name.
6. Set Security Mode (**Figure 2.5**) to “**PIN only**” or “**None**” (you could select “**PIN + MAC list**” or “**MAC list only**” security mode but in this case you need to type external device MAC address in “**Authorized Devices MAC List**” (**Figure 2.8**).
7. Set connection mode to “**OBDII**” (**Figure 2.6**).
8. Set „**External Name**“ as your Bluetooth OBD II device name for proper device identification and connection to it. In this example OBD II device name is „DONGLE“ but at least 2 characters are needed to recognize it and connect to it. For better and faster adapter identification in network you could enter a full device name. You could check your OBD II adapter Bluetooth name by scanning nearby Bluetooth devices using mobile phone or computer with Bluetooth adapter.
9. Go to “**OBD II (Bluetooth)**” in left menu and select priority and others parameters visible at **Figure 3**.

TELTONIKA		OBD II (Bluetooth)											
Input name	Units	Priority	Low level				High level		Event only		Operand	Send SMS to	SMS Text
Number Of DTC		None	Low	High	Panic	0	0	Yes	No	Monitoring			
Engine Load	%	None	Low	High	Panic	0	0	Yes	No	Monitoring			
Coolant Temperature	°C	None	Low	High	Panic	0	0	Yes	No	Monitoring			
Short Fuel Trim	%	None	Low	High	Panic	0	0	Yes	No	Monitoring			
Fuel Pressure	kPa	None	Low	High	Panic	0	0	Yes	No	Monitoring			
Intake MAP	kPa	None	Low	High	Panic	0	0	Yes	No	Monitoring			
Engine RPM	rpm	None	Low	High	Panic	0	0	Yes	No	Monitoring			
Vehicle speed	km/h	None	Low	High	Panic	0	0	Yes	No	Monitoring			
Timing advance	°	None	Low	High	Panic	0	0	Yes	No	Monitoring			
Intake air temperature	°C	None	Low	High	Panic	0	0	Yes	No	Monitoring			
MAF	g/sec	None	Low	High	Panic	0	0	Yes	No	Monitoring			
Throttle position	%	None	Low	High	Panic	0	0	Yes	No	Monitoring			
Run time since engine start	s	None	Low	High	Panic	0	0	Yes	No	Monitoring			
Distance traveled MIL on	km	None	Low	High	Panic	0	0	Yes	No	Monitoring			
Relative fuel rail pressure	kPa	None	Low	High	Panic	0	0	Yes	No	Monitoring			
Direct fuel rail pressure	kPa	None	Low	High	Panic	0	0	Yes	No	Monitoring			
Commanded EGR	%	None	Low	High	Panic	0	0	Yes	No	Monitoring			
EGR error	%	None	Low	High	Panic	0	0	Yes	No	Monitoring			
Fuel level	%	None	Low	High	Panic	0	0	Yes	No	Monitoring			
Distance traveled since codes clear	km	None	Low	High	Panic	0	0	Yes	No	Monitoring			
Barometric pressure	kPa	None	Low	High	Panic	0	0	Yes	No	Monitoring			
Control module voltage	V	None	Low	High	Panic	0	0	Yes	No	Monitoring			
Absolute load value	%	None	Low	High	Panic	0	0	Yes	No	Monitoring			
Ambient air temperature	°C	None	Low	High	Panic	0	0	Yes	No	Monitoring			
Time run with MIL on	min	None	Low	High	Panic	0	0	Yes	No	Monitoring			
Time since trouble codes cleared	min	None	Low	High	Panic	0	0	Yes	No	Monitoring			
Absolute fuel rail pressure	kPa	None	Low	High	Panic	0	0	Yes	No	Monitoring			
Hybrid battery pack remaining life	%	None	Low	High	Panic	0	0	Yes	No	Monitoring			
Engine oil temperature	°C	None	Low	High	Panic	0	0	Yes	No	Monitoring			
Fuel injection timing	°	None	Low	High	Panic	0	0	Yes	No	Monitoring			

Figure 3. OBD II Bluetooth settings.

10. After all these steps press „**Save to device**“ to save configuration (Figure 2.9).
11. Now you can disconnect FMB device from a PC or stay connected if you want to make further changes to configuration

5.2.7 Data Acquisition Mode settings

Data Acquisition Modes are an essential part of FMB001 device, it is also highly configurable.

By configuration user defines how records will be saved and sent. There are three different modes: Home, Roaming and Unknown. All these modes with configured data acquisition and send frequencies depend on current GSM Operator defined in Operator list (see section 0) and are switched when GSM operator changes (e.g. vehicle passes through country boarder).

If current GSM operator is defined as Home Operator, device will work in Home Data Acquisition mode, if current operator is defined as Roaming Operator, device will work in Roaming Data Acquisition mode, and if current operator code is not written in Operator list (but there is at least one operator code in the operator list), device will work in Unknown Acquisition mode.

This functionality allows having different AVL records acquire and send parameters values when object is moving or stands still. Vehicle moving or stop state is defined by Stop Detection

Source parameter. There are 3 ways for FMB001 to switch between Vehicle on Stop and Vehicle Moving modes see section 5.7.

FMB001 has 6 different modes. Operational logic is shown in Figure 14.



If there are no operator codes entered into operator list, FMB001 will work in Unknown network mode ONLY.

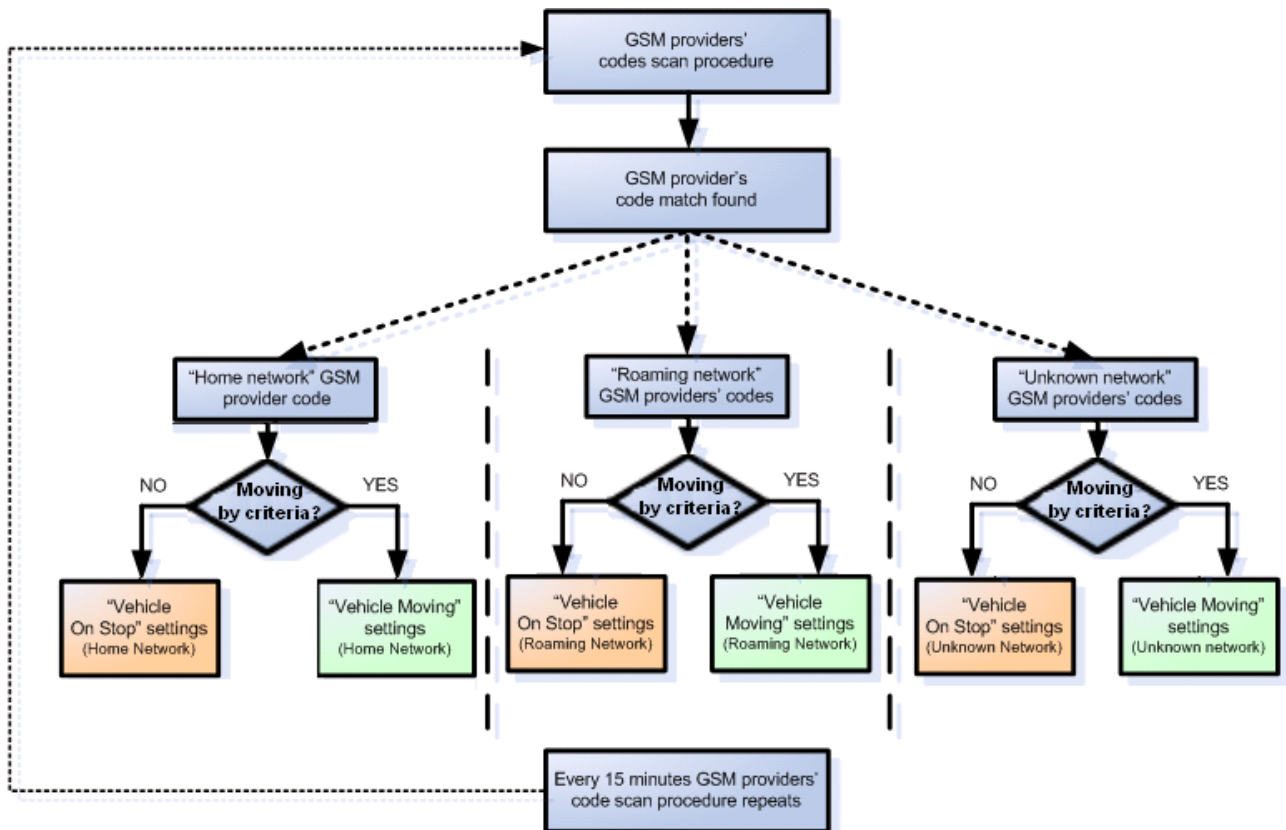

Figure 14 Data Acquisition Mode configuration

Operator search is performed every 15 minutes. Depending on current GSM operator, Home, Roaming or Unknown mode can be changed faster than every 15 minutes. This process is separate from operator search. Movement criteria are checked every second.

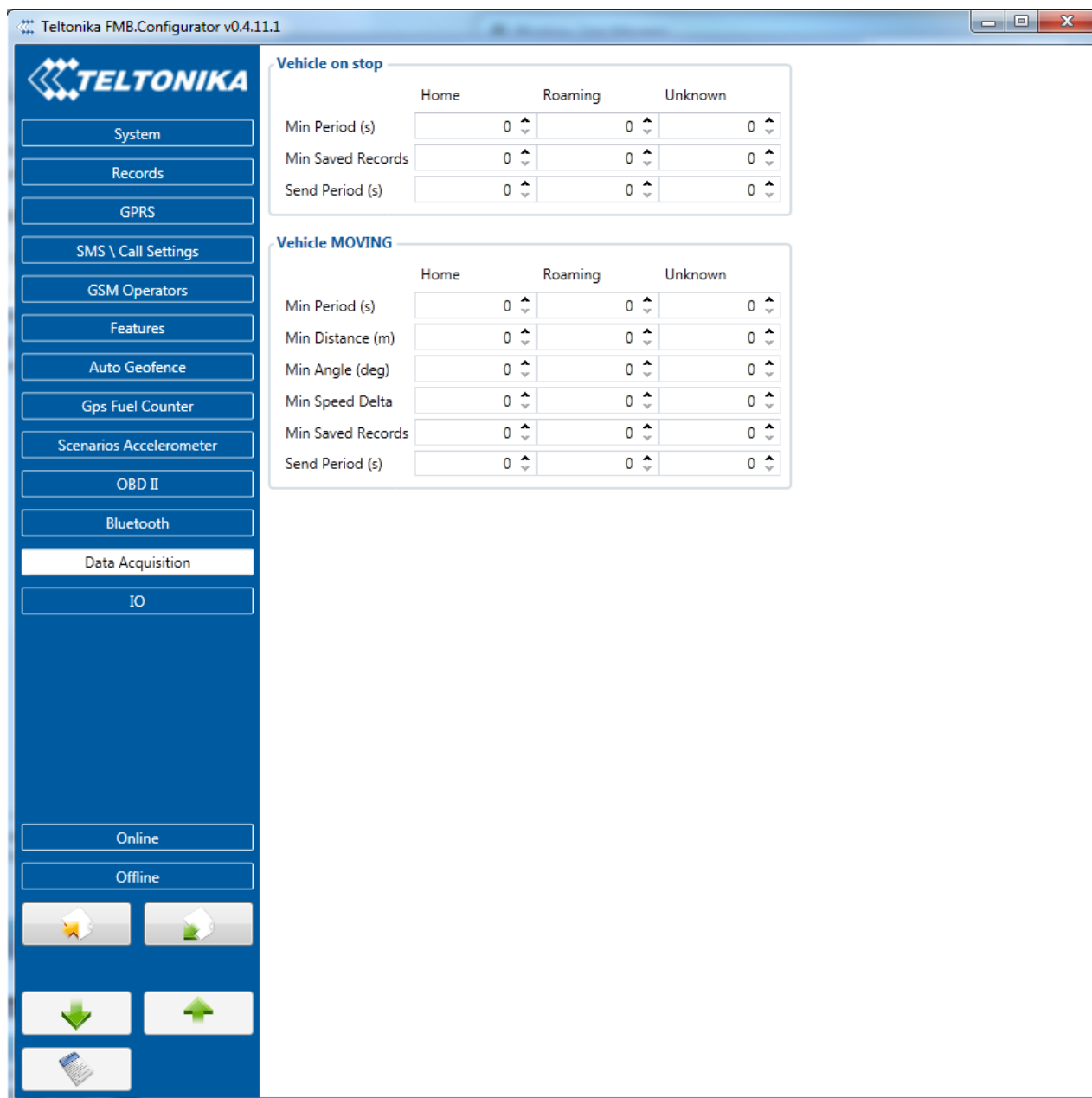

Figure 15 Data Acquisition Mode configuration

'Min Saved Records' defines minimum number of coordinates and I/O data that should be transferred with one connection to server. If FMB001 does not have enough coordinates to send to server, it will check again after time interval defined in 'Sending Period'.

Send period – GPRS data sending to server period. Module makes attempts to send collected data to server every defined period. If it does not have enough records (depends on parameter Min. Saved Records described above), it tries again after defined time interval.



Note: Keep in mind that FMB001 operates in **GMT: 0** time zone, without daylight saving.

FMB001 is able to collect records using four methods at the same time: time, distance, angle and speed based data acquisition:

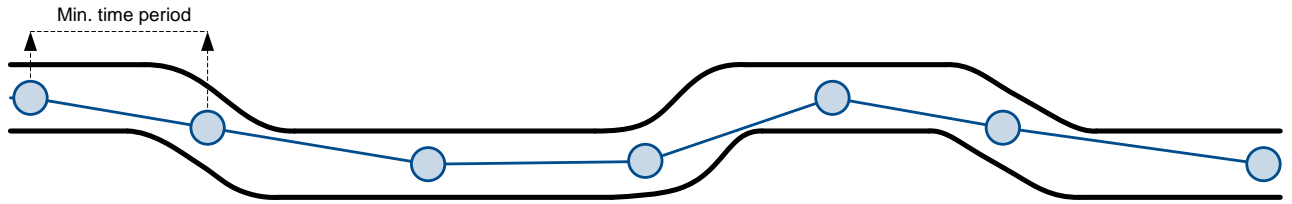

Distance based data acquiring (Min. distance) – records are being acquired when the distance between previous coordinate and current position is greater than defined parameter value. Entering zero disables data acquisition depending on distance.

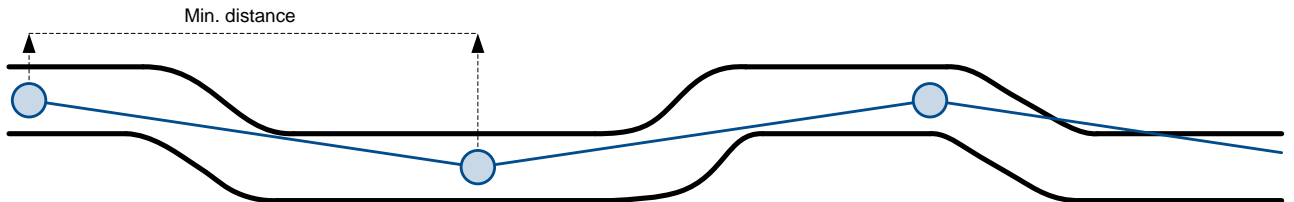

Angle based data acquiring (Min. angle) – records are being acquired when angle difference between last recorded coordinate and current position is greater than defined value. Entering zero disables data acquisition depending on angle.

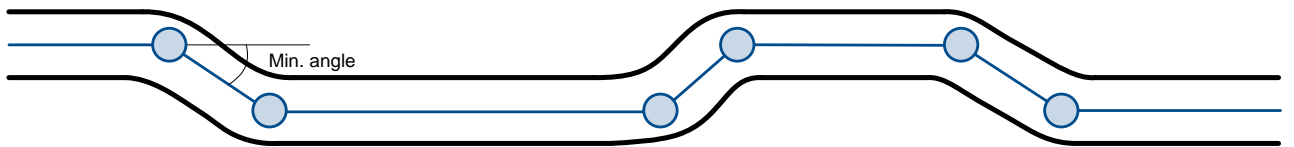

Speed based data acquiring (Min. Speed Delta) – records are being acquired when speed difference between last recorded coordinate and current position is greater than defined value. Entering zero disables data acquisition depending on speed.



5.3 OBD functionality description

5.3.1 Supported OBD protocols

1. SAE J1850 PWM (41.6 kbaud);
2. SAE J1850 VPW (10.4 kbaud);
3. ISO 9141-2 (5 baud init, 10.4 kbaud);
4. ISO 14230-4 KWP (5 baud init, 10.4 kbaud);
5. ISO 14230-4 KWP (fast init, 10.4 kbaud);
6. 15765-4 CAN (11 bit ID, 500 kbaud);
7. ISO 15765-4 CAN (29 bit ID, 500 kbaud);
8. ISO 15765-4 CAN (11 bit ID, 250 kbaud);
9. ISO 15765-4 CAN (29 bit ID, 250 kbaud);
10. SAE J1939 CAN (29 bit ID, 250 kbaud).

5.3.2 General info

Functionality supports (CAN and KLINE FAST) protocol, standard pid readout.

5.3.3 Initialization

Functionality initializes automatically, finds proper protocol and communicates using it.

5.3.4 Data

Data is saved as I/O elements. OBD I/O elements must be enabled by configurator. All OBD elements are configured in same logic as other I/O property elements.

5.4 I/O settings

When none of I/O elements are enabled, AVL packet comes with GNSS information only. After enabling I/O element(s) AVL packet along with GNSS information contains current value(s) of enabled I/O element.

Enabled or disabled field – allows enabling I/O element so it is added to the data packet and is sent to the server. By default all I/O element are disabled and FMB001 records only GNSS coordinates.

Priority (AVL packet priority) all records made by FMB001 are regular. Regular packets are sent as Low priority records. When low priority event is triggered, FMB001 makes additional record with indication that the reason for that was I/O element change.

Table 6 Permanent I/O elements

Permanent I/O elements (are always sent to server if enabled)		
Nr.	Property Name	Description

1	Ignition	Logic: 0 / 1
2	Movement	Logic: 0 / 1
3	Data mode	0 – home on stop, 1 – home on move, 2 – roaming on stop, 3 – roaming on move, 4 – unknown on stop, 5 – unknown on move
4	GSM signal	GSM signal level value in scale 1 – 5
5	Sleep mode	Logic: 0 / 1
6	GNSS Status	States: 0 – short circ., 1 – connected. Parameter defines if GPS antenna is short circuit. All the time value will be sent 1. The only condition to get value 0, then antenna is damaged and short circuit.
7	GNSS PDOP	Probability * 10; 0-500
8	GNSS HDOP	Probability * 10; 0-500
9	External Voltage	Voltage: mV, 0 – 30 V
10	Speed	Value in km/h, 0 – xxx km/h
11	GSM Cell ID	GSM base station ID
12	GSM Area Code	Location Area code (LAC), it depends on GSM operator. It provides unique number which assigned to a set of base GSM stations. Max value: 65536
13	Battery Voltage	Shows battery Voltage in mV
14	Battery Current	Shows battery Current in mA
15	Active GSM operator	Currently used GSM Operator code
16	Trip odometer	Distance between two records: m
17	Total odometer	Total odometer count: m
18	Digital Input 1	Logic: 0 / 1
19	Fuel Used GPS	Fuel used (ml) by GPS
20	Fuel Rate GPS	Fuel Consumption by average speed (l/100km)
21	Axis X	Accelerometer axis x value
22	Axis Y	Accelerometer axis y value
23	Axis Z	Accelerometer axis z value
OBD II Parameters		
24	Number Of DTC	Diagnostic Trouble Codes
25	Engine Load	Engine load percentage
26	Coolant Temperature	Engine coolant temperature, °C
27	Short Fuel Trim	Change in fuel level over short time
28	Fuel Pressure	Fuel pressure in tank
29	Intake MAP	Intake manifold absolute pressure
30	Engine RPM	Engine rotations per minute
31	Vehicle speed	Vehicle speed
32	Timing advance	Ignition timing advance
33	Intake air temperature	Intake air temperature
34	MAF	Mass air-flow meter data
35	Throttle position	Throttle position percentage

36	Run time since engine start	Run time since engine start
37	Distance traveled MIL on	Distance traveled with "Malfunction Indicator Lamp" on.
38	Relative fuel rail pressure	Fuel Rail Pressure (relative to manifold vacuum)
39	Direct fuel rail pressure	Fuel Rail Gauge Pressure (diesel, or gasoline direct injection)
40	Commanded EGR	Commanded Exhaust gas recirculation data
41	EGR error	Exhaust gas recirculation error data
42	Fuel level	Fuel Tank Level Input
43	Distance traveled since codes clear	Distance traveled since error codes clear
44	Barometric pressure	Absolute Barometric Pressure
45	Control module voltage	Control module voltage
46	Absolute load value	Absolute load value data
47	Ambient air temperature	Ambient air temperature data
48	Absolute fuel rail pressure	Absolute fuel rail pressure
49	Hybrid battery pack remaining life	Calculated remaining life of a battery pack in hybrid vehicles
50	Engine oil temperature	Engine oil temperature
51	Fuel injection timing	Fuel injection timing
52	Fuel rate	Engine fuel consumption rate

*- make sure your vehicle supports OBD communication and related OBD codes.



There are two types of operations with Permanent I/O elements: simple monitoring and event generating. Monitoring method is used when current I/O information needed with regular GNSS coordinates. Event generating method is used when additional AVL packet is needed when current value of I/O exceeds predefined High and Low levels. I/O settings allow defining I/O event criteria.

6 SMS COMMAND LIST

All commands are case sensitive. While FMB001 operates in Sleep mode and user tries to send SMS message it will arrive to FMB001 device, because GSM module is enabled. Only GNSS module is disabled in sleep mode.

6.1 SMS command list

Table 4 SMS commands

Command	Description	Response
getinfo	Returns RTC time, GPS status, SAT	Yes
getver	Returns code version, device IMEI, modem app version, RTC time	Yes

getstatus	Returns Data Link:0 GPRS:0 Phone:0 SIM:0 OP:24602 Signal:5 NewSMS:0 Roaming:0 SMSFull:0 LAC:0 Cell ID:0	Yes
getgps	Returns GPS status, Satellite number, Latitude, Longitude, Altitude, Speed, Date, Time	Yes
ggps	Returns location information with Google maps link	Yes
readio	Returns IO status	Yes
cpureset	Resets device	No
getparam	Returns selected parameter value	Yes
setparam	Sets selected parameter value	Yes
flush	Redirects device to other server	Yes
countrecs	Returns record number	Yes
setdigout X,Y	Set digital output X – 0 or 1 (0 - OFF or 1 – ON) Y – timeout value if needed (in seconds)	Yes
fc_reset	Resets fuel consumption parameters	Yes
towingreact	Towing reactivation	Yes
btgetlist	Returns requested Bluetooth list(values:0, 1, 2)	Yes
btgscan	Starts Bluetooth scan(values: none, 1)	Yes
btvisible	Sets Bluetooth to visible with TMO	Yes
btrelease	Disconnects from current device and pauses auto connect functionality for TMO	Yes
btunpair	Unpair Bluetooth device	Yes
faultcodes	Fault codes reading from OBD	Yes
obdinfo	Returns OBD info. Protocol, VIN, AdaptiveTiming value, requested PID counter, OBD application state, available vehicle PIDs, mil status, number of DTCs	Yes
cleardtc	Clears a dtc counter and deletes fault codes	Yes

Setparam and setdigout SMS is used to configure device.

Parameter ID consists of 3 or 5 digits. Detailed list of parameters and IDs can be found in chapter number 5.2 “System parameters”

Example: **‘username password setparam 102:0’** will disable sleep mode.

Multiple value setting in one sms:

Example: **‘username password setparam 2001:wap;2002:user;2003:pass’** will change configured APN name, APN username and APN password. SMS command of limited to 160 characters.

Example: **‘username password setdigout 1 60’** will set digital output ON for 60s.

6.1.1 getinfo

Response details	Description
RTC	RTC Time
GPS	GPS receiver state. 0 – OFF, 1 – restarting, 2 – ON but no fix, 3 –ON and operational, 4 – sleep mode
SAT	Average satellites

Example: RTC:2017/1/9 14:13 GPS:1 SAT:0

6.1.2 getver

Response details	Description
App Ver	Firmware version
Modem Ver	Version of modem application
GPS Ver	Version of GPS module
Hw Ver	Version of hardware
Device IMEI	IMEI

Example: App Ver:01.00.17 Rev:01 Modem Ver:TM25Q_D_01.00.00.00_010 GPS Ver:AXN_3.82_3333_1Hw Ver:FMB0_MOD2_A0:B0:C1:D0 Device IMEI:352094080000950

6.1.3 getstatus

Response details	Description
Data Link	Indicate module connection to server at the moment: 0 – Not connected, 1 – connected
GPRS	Indicate if GPRS is available at the moment
Phone	Voice Call status: 0 – ready, 1 – unavailable, 2 – unknown, 3 –ringing, 4 – call in progress, 5 – asleep
SIM	SIM Status: 0-ready, 1-pin, 2-puk, 3-pin2, 4-puk2
OP	Connected to GSM Operator: numerical id of operator
Signal	GSM Signal Quality [0-5]
NewSMS	Indicate if new message received
Roaming	0 – Home Network, 1 – roaming
SMSFull	SMS storage is full? 0 – ok, 1 – SMS storage full
LAC	GSM Tower Location Area Code
Cell ID	GSM Tower Cell ID Code

Example: Data Link: 0 GPRS: 1 Phone: 0 SIM: 0 OP: 24602 Signal: 5 NewSMS: 0 Roaming: 0 SMSFull: 0 LAC: 1 Cell ID: 3055

6.1.4 getgps

Response details	Description
GPS	Indicates valid (1) or invalid (0) Gps data
Sat	Count of currently available satellites
Lat	Latitude (Last good Latitude)
Long	Longitude (Last good Longitude)

Alt	Altitude
Speed	Ground speed, km/h
Dir	Ground direction, degrees
Date	Current date
Time	Current GMT time

Example: GPS:1 Sat:0 Lat:54.666042 Long:25.225031 Alt:0 Speed:0 Dir:0 Date: 17/1/9 Time: 12:52:30

6.1.5 ggps

Response details	Description
D	Date
T	Time
S	Actual Speed
C	Latitude (Last good Latitude), Longitude (Last good Longitude)
Url	Google Maps Link

Example: D:17/1/9 T:12:52:30 S:0.00 C:54.666042, 25.225032 Url: <http://maps.google.com/?q=54.666042,25.225032&om=1speed:0>

6.1.6 readio

Response details	Description
ID	I/O element ID
Value	I/O Element value

Example: Param ID:3 Value:0

6.1.7 getparam

Read parameter value. ID consists of 3 or 4 digits. Detailed list of parameters and IDs can be found in chapter number 8 "Parameter List"

Example: ,getparam 2001' command will request APN name

Answer: Param ID:2001 Value:wap

6.1.8 setparam

Sets new value for parameter. ID consists of 3 or 4 digits. Detailed list of parameters and IDs can be found in chapter number 8 "Parameter List"

Example: ,setparam 2001:wap2' will change configured APN name

Answer: Param ID:2001 Value:wap2

6.1.9 flush #,#,#,#,#,#

Initiates all data sending by GPRS to specified target server. Comma separated parameters go as numbered:

- 1.# - IMEI
- 2.# - APN
- 3.# - GPRS LOGIN
- 4.# - GPRS PASSWORD
- 5.# - IP
- 6.# - PORT
- 7.# - MODE (0-TCP/1-UDP)

Parameters are separated by comma (no spaces needed). In case you don't need to enter parameter (Login/Pass) – do not put space, simply put comma and write next parameter.

Example: opa opa flush 353976012555151,banga,,,212.47.99.62,12050,0

Response details	Description
FLUSH SMS Accepted	FLUSH SMS Accepted
# records found on FLASH	Number of records found on FLASH
Minimum Records to Send: #	Number of minimum saved records to send
GPRS Enabled: #	State of the GPRS connection, 0 – disabled; 1 – enabled
Time Sync: #	Indicates time synchronization on the device, 0 – not synchronized; 1 – synchronized

Example: FLUSH SMS Accepted. 11 records found on FLASH. Minimum Records to Send: 1. GPRS Enabled: 1. Time Sync: 1.

6.1.10 setdigout

Sets digital output to ON or OFF state (timeout for output is controllable)

Example: 'setdigout 1 60' will set OUT to high level for 60 seconds, 'setdigout 1' will set OUT to high level for infinite time.

6.1.11 countrecs

Returns the number of records save in the Micro SD card.

6.1.12 towingreact

Reactivates Towing Detection to initial state (does not wait for ignition to be OFF). Useful when generated false Towing event and needs reactivation.

6.1.13 faultcodes

Response details	Description
LIST	Returns list of fault codes; response when no faults: "No fault codes detected."

Example: "P0100,P0200,P0300,C0300,B0200,U0100".

6.1.14 obdinfo

Response details	Description
LIST of OBD info	Protocol, VIN, AdaptiveTiming value, requested PID counter, OBD application state, available vehicle PIDs, mil status, number of DTCs

Example:Protocol:5,VIN:N/A,TM:5,CNT:5,ST:OBDDATA
REQUESTING,P1:0x0,P2:0x0,P3:0x0,P4:0x0,MIL:0,DTC:0,IDO

6.1.15 btgetlist

btgetlist command needs argument what list should be printed!

btgetlist 0; device will respond with BT_LIST_Discovered

btgetlist 1; device will respond with all paired devices

btgetlist 2; device will respond with connected bluetooth device

Note: Without argument it is always 0 i.e **BT_LIST_Discovered**
In FW 01.00.23 btgetlist (without args) will not respond (as unknown command)

6.1.16 cleardtc

Clears a dtc counter and deletes all fault codes.

6.2 System parameters

6.2.1 Sleep Mode (ID=102)

Device has three sleep modes: sleep, deep sleep and online sleep mode. While sleep is disabled (value 0) module will never enter sleep mode, in sleep mode (value 1) module reduces level of power usage by turning GPS module to sleep, in deep sleep mode (value 2) module turns GPS module to sleep and device is deregistered from network (note, that FMB001 do not receive SMS while in deep sleep). In online sleep(value 3), device behavior is the same as in deep sleep, but GSM module stays on.

Minimum value	Maximum value	Recommended value	Goes with (depends on) parameters	Value type
0	3	-		U8

6.2.2 Sleep timeout (ID=103)

Sleep timeout is time after which FMB001 goes to sleep or deep sleep if other requirements are met. It is measured in minutes.

Minimum value	Maximum value	Recommended value	Goes with (depends on) parameters	Value type
1	3000	-		U8

6.2.3 Movement Source (ID=100)

Device can operate and change its working mode according to motion detection source: ignition (value 0), movement sensor (value 1), GPS (value 2)

Minimum value	Maximum value	Recommended value	Goes with (depends on) parameters	Value type
0	2	-		U8

6.2.4 Static Navigation (ID=106)

When static navigation is enabled, FMB001 filters out GPS jumps, when it is not moving. When it is disabled, it does not make any changes to collected GPS data.

Minimum value	Maximum value	Recommended value	Goes with (depends on) parameters	Value type
0	1	1		U8

6.2.5 Static Navigation Settings (ID=112)

Defines static navigation deactivation source. Available values: 1 – Movement, 2 – Ignition, 3 – Movement and Ignition

Minimum value	Maximum value	Recommended value	Goes with (depends on) parameters	Value type
1	3	1		U8

6.2.6 Saving/Sending without time synchronization (ID=107)

When this feature is enabled (value = 1), then records can be saved and sent to server without time synchronization.

Minimum value	Maximum value	Recommended value	Goes with (depends on) parameters	Value type
0	1	1		U8

6.2.7 GNSS Source (ID=109)

This parameter sets Satellite System, available values:

Beidou only	value:1
Glonass only	value:2
Galileo only	value:4
Galileo+Beidou	value:5
Galileo+Glonass	value:6
Gps only	value:8
Gps+Beidou	value:9
Gos+Glonass	value:10
Gps+Galileo	value:12
Gps+Galileo+Beidou	value:13
Gps+Galileo+Glonass	value:14

Minimum value	Maximum value	Recommended value	Goes with (depends on) parameters	Value type

0	14	-		U8
---	----	---	--	----

6.2.8 Ignition settings (ID=101)

This parameter sets ignition source available values : 1 – Digital Input, 2– Accelerometer, 3 - DIN1 and Accelerometer, 4 – Power voltage, 5 – DIN1 and Power voltage, 6 – Accelerometer and Power Voltage, 7 – DIN1, Accelerometer and Power Voltage, 8 – Engine RPM, 9 – DIN1 and Engine RPM, 10 – Accelerometer and Engine RPM, 11 – DIN1, Accelerometer and Engine RPM, 12 – Power Voltage and Engine RPM, 13 –DIN1, Power Voltage and Engine RPM, 14 – Accelerometer, Power Voltage and Engine RPM, 15 - DIN1, Accelerometer, Power Voltage and Engine RPM.

Minimum value	Maximum value	Recommended value	Goes with (depends on) parameters	Value type
1	15	4		U8

6.2.9 High voltage level (ID=104)

Sets high level of voltage if ignition settings is set to power voltage.

Minimum value	Maximum value	Recommended value	Goes with (depends on) parameters	Value type
0	30000	30000		U8

6.2.10 Low voltage level (ID=105)

Sets low level of voltage if ignition settings is set to power voltage.

Minimum value	Maximum value	Recommended value	Goes with (depends on) parameters	Value type
0	29999	13000		U8

6.2.11 Led indication (ID=108)

Sets led indication: 0 – disabled, 1 – enabled

Minimum value	Maximum value	Recommended value	Goes with (depends on) parameters	Value type
0	1	1		U8

6.2.12 Battery charge mode (ID=110)

Sets battery charge mode: 0 – on need, 1 – After ignition ON.

Minimum value	Maximum value	Default value	Goes with (depends on) parameters	Value type
0	1	0		U8

6.3 Records parameters

6.3.1 Sorting (ID=1002)

Record sorting parameter is responsible for record sorting order. Value of 0 arranging data starting from newest, while value of 1 arranging data starting from oldest.

Minimum value	Maximum value	Recommended value	Goes with (depends on) parameters	Value type
0	1	-		U8

6.3.2 Open Link Timeout (ID=1000)

Defines for how many seconds device will keep connection to the server after successful data transfer while waiting for a new record.

Minimum value	Maximum value	Recommended value	Goes with (depends on) parameters	Value type
0	259200	-		U32

6.3.3 Server Response Timeout (ID=1001)

Defines time period (in seconds) for server response to sent records.

Minimum value	Maximum value	Recommended value	Goes with (depends on) parameters	Value type
5	300	-		U8



ATTENTION! Some GSM operators may disconnect the device from an active data link if the device doesn't send any data for a very long time, even if active data link timeout is set to maximum value. The amount of time that an operator keeps the link open depends solely on the operator. For example, if active data link timeout is set to maximum, 259200 seconds (72 hours), and the device sends data to server every 86400 seconds (24 hours), the operator might disconnect the link earlier and the device will have to connect to the server anew. This may cost extra, depending on the operator GPRS data charge. It is strongly recommended, when using active data link timeout, that data sending to the server should not be very rare (24 hours or more). If data sending is more frequent, then the operator will not disconnect the device from the server.

6.4 GSM parameters

6.4.1 GPRS content activation (ID=2000)

Parameter allows or does not allow GPRS usage. If GPRS is not allowed value is 0, if GPRS is allowed value is 1.

Minimum value	Maximum value	Recommended value	Goes with (depends on) parameters	Value type
0	1	-	APN Name (ID=2001) APN username (ID=2002)	S8

			APN Password (ID=2003)	
--	--	--	------------------------	--

6.4.2 APN Name (ID=2001)

Parameter defines GPRS Access Point Name.

Minimum value	Maximum value	Recommended value	Goes with (depends on) parameters	Value type
Empty	32 char string	-	GPRS content activation (ID=2000) APN username (ID=2002) APN Password (ID=2003)	S8[32]

6.4.3 APN username (ID=2002)

Parameter defines APN username. In case operator does not use username for login, value should be empty.

Minimum value	Maximum value	Recommended value	Goes with (depends on) parameters	Value type
Empty	30 char string	-	GPRS content activation (ID=2000) APN Name (ID=2001) APN Password (ID=2003)	S8[30]

6.4.4 APN Password (ID=2003)

Parameter defines APN password. In case operator does not use password for login, value should be empty.

Minimum value	Maximum value	Recommended value	Goes with (depends on) parameters	Value type
Empty	30 char string	-	GPRS content activation (ID=2000) APN Name (ID=2001) APN username (ID=2002)	S8[30]

6.4.5 Domain (ID=2004)

Parameter defines AVL data destination server IP address. Example: 212.47.99.62

Minimum value	Maximum value	Recommended value	Goes with (depends on) parameters	Value type
0	54 char string	-	GPRS content activation (ID=2000)	S8[16]

6.4.6 Target Server Port (ID=2005)

Parameter defines AVL data destination server port number. Example: 12050

Minimum	Maximum	Recommended	Goes with (depends on)	Value
---------	---------	-------------	------------------------	-------

value	value	value	parameters	type
Empty	65535	-	GPRS content activation (ID=2000)	U16

6.4.7 Protocol (ID=2006)

Parameter defines GPRS data transport protocol. Module can use TCP or UDP transport protocol to send data to server. For TCP protocol value is 0, for UDP protocol value is 1.

Minimum value	Maximum value	Recommended value	Goes with (depends on) parameters	Value type
0	1	-	GPRS content activation (ID=2000)	U8

6.5 SMS/Call settings

6.5.1 SMS data sending settings (ID=3000)

Parameter allows or does not allow sending AVL data using binary SMS. If SMS use is not allowed value is 0 and 1 if SMS use is allowed.

Minimum value	Maximum value	Recommended value	Goes with (depends on) parameters	Value type
0	1	-		

6.5.2 Data send number (ID=3001)

In this field are written GSM numbers, to which will be sent Data SMS.

Minimum value	Maximum value	Recommended value	Goes with (depends on) parameters	Value type
1 digit	16 digits	-		S8

6.5.3 Authorized phone numbers (ID=4000-4009)

If at least one number is entered then only those number can send messages to device. Number must be entered without "+" or "00".

Example: 37060012346

Minimum value	Maximum value	Recommended value	Goes with (depends on) parameters	Value type
1 digit	16 digits	-		String

6.5.4 SMS Event Predefined Numbers (ID=6000-6009)

In this field GSM numbers are written, to which will be sent "Event SMS" text message. Number must be entered without "+" or "00".

Example: 37060012346

Minimum value	Maximum value	Recommended value	Goes with (depends on) parameters	Value type
1 digit	16 digits	-		String

6.5.5 SMS Login (ID=3003)

User login is used to ensure module security. Used in every SMS that is sent to device.
Example: ba321

Minimum value	Maximum value	Recommended value	Goes with (depends on) parameters	Value type
Empty	5 char	-	SMS Password (ID=3004)	S8[5]

6.5.6 SMS Password (ID=3004)

User password is used to ensure module security. Used in every SMS that is sent to device.
Example: ab123

Minimum value	Maximum value	Recommended value	Goes with (depends on) parameters	Value type
Empty	5 char	-		S8[5]

6.5.7 Incoming call action (ID=3005)

Parameter defines action during call: 0 – do nothing, 1 – hang up, 2 – report position

Minimum value	Maximum value	Recommended value	Goes with (depends on) parameters	Value type
0	2	0		S8[17]

6.5.8 Outgoing Call Trigger (ID=3007)

Parameter defines hands free call trigger: 0 – Disable, 1 – DIN1, 2 – Crash event, 3 – DIN1 and Crash event, 4 – DIN2*, 5 – DIN1 and DIN2*, 6 – Crash event and DIN2*, 7 – DIN1, Crash event and DIN2.

Minimum value	Maximum value	Recommended value	Goes with (depends on) parameters	Value type
0	7	-		UInt8

Hardware dependant: DIN2 input is supported on FMB1YX hardwares only

6.5.9 GSM number index (ID=3008)

Parameter defines gsm number's, in predefined number list, index.

Minimum value	Maximum value	Recommended value	Goes with (depends on) parameters	Value type
0	9	-		UInt8

6.5.10 Operator List (ID=5000-5049)

Parameter defines operator list. According to this list module selects operating profile. First in a list is *Home Operator Code*, then Preferred Roaming Operator Codes are written.

Minimum value	Maximum value	Recommended value	Goes with (depends on) parameters	Value type
Empty	7 digits	-		U32

6.6 Data Acquisition Modes parameters

6.6.1 Home Network GSM operator code “Vehicle on STOP” parameters

6.6.1.1 Min Period (ID=10000)

This parameter indicates time interval in seconds in order to acquire new record. If value is 0 it means no records by min period will be saved.

Minimum value	Maximum value	Recommended value	Goes with (depends on) parameters	Value type
0	2592000	-		U32

6.6.1.2 Min Saved Records (ID=10004)

This parameter defines minimum number of records in one data packet that can be sent to server. It has higher priority than Data Send Period (ID=10005).

Minimum value	Maximum value	Recommended value	Goes with (depends on) parameters	Value type
1	255	1		U8

6.6.1.3 Send Period (ID=10005)

This parameter indicates frequency (time interval in seconds) of sending data to server.

Minimum value	Maximum value	Recommended value	Goes with (depends on) parameters	Value type
0	2592000	-	Min Saved Records (ID=10004)	U32

6.6.2 Home Network GSM operator code “Vehicle MOVING” parameters

6.6.2.1 Min Period (ID=10050)

This parameter indicates time interval in seconds in order to acquire new record. If value is 0 it means no records by min period will be saved.

Minimum value	Maximum value	Recommended value	Goes with (depends on) parameters	Value type
0	2592000	-	Min Distance (ID=10051) Min Angle (ID=10052)	U32

6.6.2.2 Min Distance (ID=10051)

This parameter indicates distance in meters in order to acquire new record. Record is stored when the distance between previous records is greater than parameters value. If value is 0 it means no records by min distance will be saved.

Minimum value	Maximum value	Recommended value	Goes with (depends on) parameters	Value type

0	65535	-	Min Period (ID=10050) Min Angle (ID=10052)	U32
---	-------	---	---	-----

6.6.2.3 Min Angle (ID=10052)

This parameter indicates angle in degrees in order to acquire new record. If angle difference between last recorded coordinate and current position is greater than defined value, new record is stored. This parameter is operational, when speed is higher than 10km/h. If value is 0 it means no records by min angle will be saved.

Minimum value	Maximum value	Recommended value	Goes with (depends on) parameters	Value type
0	180	-	Min Period (ID=10050) Min Distance (ID=10051)	U16

6.6.2.4 Min Speed delta (ID=10053)

This parameter indicates speed difference in order to acquire new record. If speed difference between last recorded coordinate and current position is greater than defined value, new record is stored. If value is 0 it means no records by min distance will be saved.

Minimum value	Maximum value	Recommended value	Goes with (depends on) parameters	Value type
0	255	10	Min Period (ID=10050) Min Distance (ID=10051) Min Angle (ID=10052)	U16

6.6.2.5 Min Saved Records (ID=10054)

This parameter defines minimum number of records in one data packet that can be sent to server. It has higher priority than Data Send Period (ID=10055).

Minimum value	Maximum value	Recommended value	Goes with (depends on) parameters	Value type
1	255	1	Min Period (ID=10050) Min Distance (ID=10051) Min Angle (ID=10052)	U8

6.6.2.6 Send Period (ID=10055)

This parameter indicates frequency (time interval in seconds) of sending data to server.

Minimum value	Maximum value	Recommended value	Goes with (depends on) parameters	Value type
0	2592000	-		U32

6.6.3 Roaming Network GSM operator code "Vehicle on STOP" parameters

6.6.3.1 Min Period (ID=10100)

This parameter indicates time interval in seconds in order to acquire new record. If value is 0 it means no records by min period will be saved.

Minimum	Maximum	Recommended	Goes with (depends on)	Value
---------	---------	-------------	------------------------	-------

value	value	value	parameters	type
0	2592000	-		U32

6.6.3.2 Min Saved Records (ID=10104)

This parameter defines minimum number of records in one data packet that can be sent to server. It has higher priority than Data Send Period (ID=10105).

Minimum value	Maximum value	Recommended value	Goes with (depends on) parameters	Value type
1	255	1		U8

6.6.3.3 Send Period (ID=10105)

This parameter indicates frequency (time interval in seconds) of sending data to server.

Minimum value	Maximum value	Recommended value	Goes with (depends on) parameters	Value type
0	2592000	-	Min Saved Records (ID=10104)	U32

6.6.4 Roaming Network GSM operator code "Vehicle MOVING" parameters

6.6.4.1 Min Period (ID=10150)

This parameter indicates time interval in seconds in order to acquire new record. If value is 0 it means no records by min period will be saved.

Minimum value	Maximum value	Recommended value	Goes with (depends on) parameters	Value type
0	2592000	-	Min Distance (ID=10151) Min Angle (ID=10152)	U32

6.6.4.2 Min Distance (ID=10151)

This parameter indicates distance in meters in order to acquire new record. Record is stored when the distance between previous records is greater than parameter's value. If value is 0 it means no records by min distance will be saved.

Minimum value	Maximum value	Recommended value	Goes with (depends on) parameters	Value type
0	65535	-	Min Period (ID=10150) Min Angle (ID=10152)	U32

6.6.4.3 Min Angle (ID=10152)

This parameter indicates angle in degrees in order to acquire new record. If angle difference between last recorded coordinate and current position is greater than defined value, new record is stored. This parameter is operational, when speed is higher than 10km/h. If value is 0 it means no records by min angle will be saved.

Minimum value	Maximum value	Recommended value	Goes with (depends on) parameters	Value type

0	180	-	Min Period (ID=10150)	U16
---	-----	---	-----------------------	-----

6.6.4.4 Min Speed (ID=10153)

This parameter indicates speed difference in order to acquire new record. If speed difference between last recorded coordinate and current position is greater than defined value, new record is stored. If value is 0 it means no records by min distance will be saved.

Minimum value	Maximum value	Recommended value	Goes with (depends on) parameters	Value type
0	255	10	Min Period (ID=10150) Min Distance (ID=10151) Min Angle (ID=10152)	U16

6.6.4.5 Min Saved Records (ID=10154)

This parameter defines minimum number of records in one data packet that can be sent to server. It has higher priority than Data Send Period (ID=10155).

Minimum value	Maximum value	Recommended value	Goes with (depends on) parameters	Value type
1	255	1		U8

6.6.4.6 Send Period (ID=10155)

This parameter indicates frequency (time interval in seconds) of sending data to server.

Minimum value	Maximum value	Recommended value	Goes with (depends on) parameters	Value type
0	2592000	-	Min Saved Records (ID=10154)	U32

6.6.5 Unknown Network GSM operator code "Vehicle on STOP" parameters

6.6.5.1 Min Period (ID=10200)

This parameter indicates time interval in seconds in order to acquire new record. If value is 0 it means no records by min period will be saved.

Minimum value	Maximum value	Recommended value	Goes with (depends on) parameters	Value type
0	2592000	-		U32

6.6.5.2 Min Saved Records (ID=10204)

This parameter defines minimum number of records in one data packet that can be sent to server. It has higher priority than Data Send Period (ID=10205).

Minimum value	Maximum value	Recommended value	Goes with (depends on) parameters	Value type
1	255	1		U8

6.6.5.3 Send Period (ID=10205)

This parameter indicates frequency (time interval in seconds) of sending data to server.

Minimum value	Maximum value	Recommended value	Goes with (depends on) parameters	Value type
0	2592000	-	Min Saved Records (ID=10204)	U32

6.6.6 Unknown Network GSM operator code “Vehicle MOVING” parameters

6.6.6.1 Min Period (ID=10250)

This parameter indicates time interval in seconds in order to acquire new record. If value is 0 it means no records by min period will be saved.

Minimum value	Maximum value	Recommended value	Goes with (depends on) parameters	Value type
0	2592000	-	Min Distance (ID=10151) Min Angle (ID=10152)	U32

6.6.6.2 Min Distance (ID=10251)

This parameter indicates distance in meters in order to acquire new record. Record is stored when the distance between previous records is greater than parameter’s value. If value is 0 it means no records by min distance will be saved.

Minimum value	Maximum value	Recommended value	Goes with (depends on) parameters	Value type
0	65535	-	Min Angle (ID=10152) Min Period (ID=10150)	U32

6.6.6.3 Min Angle (ID=10252)

This parameter indicates angle in degrees in order to acquire new record. If angle difference between last recorded coordinate and current position is greater than defined value, new record is stored. This parameter is operational, when speed is higher than 10km/h. If value is 0 it means no records by min angle will be saved.

Minimum value	Maximum value	Recommended value	Goes with (depends on) parameters	Value type
0	180	-	Min Period (ID=10150)	U16

6.6.6.4 Min Speed (ID=10253)

This parameter indicates speed difference in order to acquire new record. If speed difference between last recorded coordinate and current position is greater than defined value, new record is stored. If value is 0 it means no records by min distance will be saved.

Minimum value	Maximum value	Recommended value	Goes with (depends on) parameters	Value type
0	255	10	Min Period (ID=10150) Min Distance (ID=10151) Min Angle (ID=10152)	U16

6.6.6.5 Min Saved Records (ID=10254)

This parameter defines minimum number of records in one data packet that can be sent to server. It has higher priority than Data Send Period (ID=10105).

Minimum value	Maximum value	Recommended value	Goes with (depends on) parameters	Value type
1	255	1		U8

6.6.6.6 Send Period (ID=10255)

This parameter indicates frequency (time interval in seconds) of sending data to server.

Minimum value	Maximum value	Recommended value	Goes with (depends on) parameters	Value type
0	2592000	-	Min Saved Records (ID=10254)	U32

6.7 Features Parameters

6.7.1 Green driving priority (ID=11000)

Defines priority of green driving scenario:

0 – disabled, 1 – low, 2 – high, 3 – panic

Minimum value	Maximum value	Recommended value	Goes with (depends on) parameters	Value type
0	3	-		U8

6.7.2 Max Acceleration Force (ID=11004)

It is max allowed acceleration force which can be reached while accelerating without triggering harsh acceleration event.

Minimum value	Maximum value	Default value	Goes with (depends on) parameters	Value type
0.5	10	2.2		Float

6.7.3 Max Braking Force (ID=11005)

It is max allowed braking force which can be reached while braking without triggering harsh braking event.

Minimum value	Maximum value	Default value	Goes with (depends on) parameters	Value type
0.5	10	2.5		Float

6.7.4 Max Cornering (ID=11006)

It is max allowed cornering angle which can be reached while cornering without triggering harsh cornering event.

Minimum value	Maximum value	Default value	Goes with (depends on) parameters	Value type
0.5	10	2.1		Float

6.7.5 Green/Eco driving (ID=11007)

Choose between Eco driving(accelerometer) and Green driving(gps). 0 – GPS, 1 – Accelerometer

Minimum value	Maximum value	Default value	Goes with (depends on) parameters	Value type
0	1	0		U16

6.7.6 Green driving digital output control settings (ID=11003)

Sets digital output off (0) or on (1)

Minimum value	Maximum value	Recommended value	Goes with (depends on) parameters	Value type
0	1	0		Float

6.7.7 Green driving Digital output on duration (ID=11001)

Output ON duration in mili-seconds

Minimum value	Maximum value	default value	Goes with (depends on) parameters	Value type
0	2147483647	200		Float

6.7.8 Green driving Digital output off duration (ID=11002)

Output OFF duration in in mili-seconds

Minimum	Maximum	default value	Goes with (depends on)	Value

value	value		parameters	type
0	21474836 47	200		Float

6.7.9 Overspeeding priority (ID=11100)

Defines priority of overspeeding scenario:

0 – disabled, 1 – low, 2 – high, 3 – panic

Minimum value	Maximum value	Recommended value	Goes with (depends on) parameters	Value type
0	3	-		U8

6.7.10 Max allowed Speed (ID=11104)

It is max allowed speed which can be reached. If this value exceeded Over speeding event will occur.

Minimum value	Maximum value	Recommended value	Goes with (depends on) parameters	Value type
0	260	-		U16

6.7.11 Overspeeding output control (ID=11103)

Enables (1) or disables (0) overspeeding output control

Minimum value	Maximum value	Recommended value	Goes with (depends on) parameters	Value type
0	1	0		Float

6.7.12 Overspeeding Digital output on duration (ID=11101)

Output ON duration in mili-seconds

Minimum value	Maximum value	Default value	Goes with (depends on) parameters	Value type
0	21474836 47	200		U8

6.7.13 Overspeeding Digital output off duration (ID=11102)

Output OFF duration in mili-seconds

Minimum value	Maximum value	Default value	Goes with (depends on) parameters	Value type
0	21474836 47	200		U8

6.7.14 Excessive idling priority (ID=11200)

Defines priority of Excessive idling scenario:

0 – disabled, 1 – low, 2 – high, 3 – panic

Minimum value	Maximum value	Recommended value	Goes with (depends on) parameters	Value type
0	3	-		U8

6.7.15 Eventual records (ID=11203)

Disables (0) or enables (1) eventual records with idling value

Minimum value	Maximum value	Recommended value	Goes with (depends on) parameters	Value type
0	1	-		U16

6.7.16 Excessive idling minimum stop duration (ID=11205)

Defines minimum time in seconds of vehicle idling before scenario enables.

Minimum value	Maximum value	Default value	Goes with (depends on) parameters	Value type
0	255	5		Float

6.7.17 Excessive idling minimum move duration (ID=11206)

Defines minimum time in seconds of vehicle idling before scenario disables.

Minimum value	Maximum value	Default value	Goes with (depends on) parameters	Value type
0	255	2		Float

6.7.18 Excessive idling output control (ID=11204)

Enables (1) or disables (0) Excessive idling output control

Minimum value	Maximum value	Recommended value	Goes with (depends on) parameters	Value type
0	1	0		U16

6.7.19 Excessive idling output on duration (ID=11201)

Output ON duration in seconds

Minimum value	Maximum value	Default value	Goes with (depends on) parameters	Value type
0	21474836 47	0		Float

6.7.20 Excessive idling output off duration (ID=11202)

Output OFF duration in seconds

Minimum value	Maximum value	Default value	Goes with (depends on) parameters	Value type
0	21474836 47	0		Float

6.7.21 Jamming (ID=11300)

Scenario settings: 0 – Disable, 1 – Low, 2 – High, 3 – Panic

Minimum value	Maximum value	Default value	Goes with (depends on) parameters	Value type
0	3	0		U8

6.7.22 Jamming Eventual records (ID=11303)

Disables or enables eventual records. 0 – Disable, 1 – Enable

Minimum value	Maximum value	Default value	Goes with (depends on) parameters	Value type
0	1	1		U8

6.7.23 Jamming Output Control (ID=11304)

Defines rather jamming will control digital output or not. 0 – Disable, 1 – Enable.

Minimum value	Maximum value	Default value	Goes with (depends on) parameters	Value type
0	1	0		U8

6.7.24 Jamming DOUT on duration [ms] (ID=11301)

Sets time period, that Dout will be on.

Minimum value	Maximum value	Default value	Goes with (depends on) parameters	Value type
0	21474836 47	200		U8

6.7.25 Jamming DOUT off duration [ms] (ID=11302)

Sets time period, that Dout will be off.

Minimum value	Maximum value	Default value	Goes with (depends on) parameters	Value type
0	21474836 47	200		U8

6.7.26 DOUT control via call (ID=12000)

Disables or enables dout control via call. 0 – Disable, 1 – Enable.

Minimum value	Maximum value	Default value	Goes with (depends on) parameters	Value type
0	1	0		U8

6.7.27 DOUT deactivation settings (ID=12001)

Enables or disables dout deactivation by Din1. 0 – Disable, 1 – Enable.

Minimum value	Maximum value	Default value	Goes with (depends on) parameters	Value type
0	1	0		U8

6.7.28 DOUT duration timeout [s] (ID=12002)

Defines the time that dout will be activated for.

Minimum value	Maximum value	Default value	Goes with (depends on) parameters	Value type
0	2147483647	5		U8

6.7.29 Trip priority priority (ID=11800)

Defines priority of trip scenario:

0 – disabled, 1 – low, 2 – high, 3 – panic

Minimum value	Maximum value	Default value	Goes with (depends on) parameters	Value type
0	3	0		U8

6.7.30 Start Speed (ID=11803)

This parameter represents speed, which is detected as minimum speed to indicate TRIP START and generate event.

Minimum value	Maximum value	Recommended value	Goes with (depends on) parameters	Value type
0	255	-	Trip priority priority (ID=11800)	U8

6.7.31 Ignition Off Timeout (ID=11804)

This parameter represents timeout to wait if ignition is off in order to detect TRIP STOP and generate event.

Minimum value	Maximum value	Recommended value	Goes with (depends on) parameters	Value type
0	65535	-	Trip priority priority (ID=11800)	U16

6.7.32 Trip mode (ID=11802)

For this feature I/O ODOMETER must be enabled. If I/O ODOMETER is enabled, and mode is set to Continuous (value 0), TRIP distance is going to be counted till the end of trip, if between records mode is set, ODOMETER will count distance only between two records.

Minimum value	Maximum value	Recommended value	Goes with (depends on) parameters	Value type
0	1	-	Trip priority priority (ID=11800)	U8

6.8 AutoGeofencing

6.8.1.1 AutoGeofencing priority (ID=20000)

Defines priority of trip scenario:

0 – disabled, 1 – low, 2 – high, 3 – panic

Minimum value	Maximum value	Recommended value	Goes with (depends on) parameters	Value type
0	3	0		U8

6.8.1.2 Activation Timeout (ID=20003)

Parameter represents AutoGeofencing activation timeout in seconds.

Minimum value	Maximum value	Recommended value	Goes with (depends on) parameters	Value type
0	65535	60	AutoGeofencing priority (ID=20000)	U16

6.8.1.3 Deactivate by (ID=20005)

Parameter defines Autogeofence deactivation source. Value 0 – for Ignition, - Power Voltage, Digital Input 1

Minimum value	Maximum value	Recommended value	Goes with (depends on) parameters	Value type
0	2	-	AutoGeofencing priority (ID=20000)	U8

6.8.1.4 AutoGeofence event generating (ID=20001)

Generate event: 0 – on exiting zone , 1 – on entering zone; 2 – on both;

Minimum value	Maximum value	Recommended value	Goes with (depends on) parameters	Value type
0	2	0	AutoGeofencing priority (ID=20000)	U8

6.8.1.5 Radius (ID=20004)

Parameter represents radius of circle with center device coordinates after activating AutoGeofence feature.

Minimum value	Maximum value	Recommended value	Goes with (depends on) parameters	Value type
0	1000000	100	AutoGeofencing priority (ID=20000) Deactivate by (ID=20005)	U32

6.9 GPS Fuel counter

6.9.1.1 City Consumption L/100km (ID=11900)

Consumption in the city

Minimum	Maximum	Default value	Goes with (depends on)	Value
---------	---------	---------------	------------------------	-------

value	value		parameters	type
0	50	0		Double

6.9.1.2 Highway Consumption L/100km (ID=11901)

Consumption on highway

Minimum value	Maximum value	Default value	Goes with (depends on) parameters	Value type
0	50	0		Double

6.9.1.3 Average Consumption L/100km (ID=11902)

Average fuel consumption of the vehicle

Minimum value	Maximum value	Default value	Goes with (depends on) parameters	Value type
0	50	0		Double

6.9.1.4 City Speed [km/h] (ID=11903)

Speed in the city

Minimum value	Maximum value	Default value	Goes with (depends on) parameters	Value type
0	250	30		Unit64

6.9.1.5 Highway Speed [km/h] (ID=11904)

Speed on highway

Minimum value	Maximum value	Default value	Goes with (depends on) parameters	Value type
0	250	90		Unit64

6.9.1.6 Average Speed [km/h] (ID=11905)

Average speed of the vehicle

Minimum value	Maximum value	Default value	Goes with (depends on) parameters	Value type
0	250	60		Unit64

6.9.1.7 Correction coefficient (ID=11906)

Sets the correction coefficient

Minimum value	Maximum value	Default value	Goes with (depends on) parameters	Value type
0.01	2	1		Double

6.9.1.8 Fuel Consumption on Idling [L/h] (ID=11907)

Sets fuel consumption while vehicle is idling

Minimum value	Maximum value	Default value	Goes with (depends on) parameters	Value type
0	5	1		Double

6.9.1.9 Higher Speeds Add [%] (ID=11908)

Minimum value	Maximum value	Default value	Goes with (depends on) parameters	Value type
0	250	20		Unit64

6.9.1.10 Highway Consumption every km/h (ID=11909)

Minimum value	Maximum value	Default value	Goes with (depends on) parameters	Value type
0	100	50		Unit64

6.10 Scenarios Accelerometer

6.10.1 Unplug Detection

6.10.1.1 Scenario settings (ID=11500)

Sets priority of the scenario: 0 – Disable, 1 – Low Priority, 2 – High Priority, 3 – Panic Priority

Minimum value	Maximum value	default value	Goes with (depends on) parameters	Value type
0	3	0		U64

6.10.1.2 Eventual records (ID=11501)

If enabled, only eventual records of unplug detection will be sent. 0 – Disable, 1 - Enable

Minimum value	Maximum value	default value	Goes with (depends on) parameters	Value type
0	1	1		U64

6.10.1.3 Unplug detection mode (ID=11502)

Sets Unplug detection mode. 0 – simple, 1 – advanced.

Simple – unplug detection according to external voltage only

Advanced – unplug detection according to: external voltage OR accelerometer

Minimum value	Maximum value	default value	Goes with (depends on) parameters	Value type
0	1	0		U64

6.10.1.4 Send sms to (ID=7067)

Enable/disable sms event sending. 0 – Disable, 1-10 – sms will be sent to configured GSM number. (SMS \ Call Settings -> GSM Predefined Numbers list.)

Minimum value	Maximum value	default value	Goes with (depends on) parameters	Value type
0	10	0		U64

6.10.1.5 SMS Text (ID=8067)

Configure uplug sms event text here.

Minimum value	Maximum value	default value	Goes with (depends on) parameters	Value type

0	160	0		U64
---	-----	---	--	-----

Note: „Unplug Detection“ work just in device with battery. FMB001 doesn't have this.

6.10.2 Crash Detection

6.10.2.1 Scenario settings (ID=11400)

Sets priority of the scenario: 0 – Disable, 1 – Low Priority, 2 – High Priority, 3 – Panic Priority

Minimum value	Maximum value	default value	Goes with (depends on) parameters	Value type
0	3	0		U64

6.10.2.2 Duration [ms] (ID=11401)

Minimum value	Maximum value	default value	Goes with (depends on) parameters	Value type
0	2000	5		U64

6.10.2.3 Treshold [mG] (ID=11402)

Minimum value	Maximum value	default value	Goes with (depends on) parameters	Value type
0	7900	1500		U64

6.10.2.4 Crash trace (ID=11406)

Minimum value	Maximum value	default value	Goes with (depends on) parameters	Value type
0	1	0		U64

6.11 Bluetooth

6.11.1.1 BT Radio (ID=800)

Enables or disable Bluetooth feature. 0 – Disabled, 1 – Enable hidden, 2 – Enable visible

Minimum value	Maximum value	default value	Goes with (depends on) parameters	Value type
0	2	0		U64

6.11.1.2 Local name (ID 801)

Parameter defines a visible name of FMBX device.

Minimum value	Maximum value	default value	Goes with (depends on) parameters	Value type
0 Symbols	30 Symbols	-		String

6.11.1.3 Local PIN (ID=802)

Parameter Lets to configure Bluetooth PIN.

Minimum value	Maximum value	default value	Goes with (depends on) parameters	Value type

0 Symbols	4 Symbols	5555		String
-----------	-----------	------	--	--------

6.11.1.4 Security mode (ID=803)

Parameter defines a security mode of FMBX device. 0 – PIN only, 1 – PIN and MAC, 2 – MAC only, 3 – None.

Minimum value	Maximum value	default value	Goes with (depends on) parameters	Value type
0	3	0		U64

6.11.1.5 External MAC (ID=804)

Defines external device's MAC, for FMB001 to auto connect to.

Minimum value	Maximum value	default value	Goes with (depends on) parameters	Value type
0 symbols	12 symbols	0		string

6.11.1.6 External name (ID=805)

Defines external device's name, for FMB001 to auto connect to.

Minimum value	Maximum value	default value	Goes with (depends on) parameters	Value type
0 symbols	30 symbols	0		string

6.11.1.7 External PIN (ID=806)

Defines external device's PIN, for FMB001 to auto connect to.

Minimum value	Maximum value	default value	Goes with (depends on) parameters	Value type
0 symbols	8 symbols	0		string

6.11.1.8 Connection mode (ID=807)

Defines a mode in which FMB001 will connect to external devices. 0 – None, 1 – FMB001 will connect to Hands Free Headset, 2 – FMB001 will connect to OBDII Bluetooth dongle.

Minimum value	Maximum value	default value	Goes with (depends on) parameters	Value type
0	2	0		U64

6.11.1.9 Authorized devices MAC list (ID=830 - 834)

Parameter allows to add an authorized devices MAC for connection to FMB001

Minimum value	Maximum value	default value	Goes with (depends on) parameters	Value type
0 symbols	12 symbols	-		String

6.12 I/O parameters

I/O properties are additional data sources which are recorded along with usual GPS data.

6.12.1 I/O#1 property parameter Ignition (ID=50000)

Parameter defines I/O property value. Possible values: 0-Disabled; 1-Low; 2-High; 3-Panic.

Minimum value	Maximum value	Recommended value	Goes with (depends on) parameters	Value type
0	3	-	I/O#1 priority (ID=50000) I/O#1 logic operand (ID=50001) I/O#1 High level (ID=50002) I/O#1 Low level (ID=50003) I/O#1 Event only (ID=50004) I/O#1 averaging length (ID=50005)	S8

6.12.2 I/O#1 Logic operand (ID=50001)

Parameter defines eventual record is saved. Possible values: 0 – On Exit; 1-On Entrance; 2-Both; 3-Monitoring; 4-Hysteris; 5-On Change; 6-On Delta Change

Minimum value	Maximum value	Recommended value	Goes with (depends on) parameters	Value type
0	6	0	I/O#1 priority (ID=50000) I/O#1 logic operand (ID=50001) I/O#1 High level (ID=50002) I/O#1 Low level (ID=50003) I/O#1 Event only (ID=50004) I/O#1 averaging length (ID=50005)	S8

6.12.3 I/O#1 High level (ID=50002)

Parameter defines high value of triggered I/O property. This parameter is used to set thresholds for I/O properties to generate events.

Minimum value	Maximum value	Recommended value	Goes with (depends on) parameters	Value type
-2147483647	2147483647	1	I/O#1 priority (ID=50000) I/O#1 logic operand (ID=50001) I/O#1 High level (ID=50002) I/O#1 Low level (ID=50003) I/O#1 Event only (ID=50004) I/O#1 averaging length (ID=50005)	S32

6.12.4 I/O#1 Low level (ID=50003)

Parameter defines low value of triggered I/O property. This parameter is used to set thresholds for I/O properties to generate events.

Minimum value	Maximum value	Recommended value	Goes with (depends on) parameters	Value type
-2147483647	2147483647	0	I/O#1 priority (ID=50000) I/O#1 logic operand (ID=50001) I/O#1 High level (ID=50002) I/O#1 Low level (ID=50003) I/O#1 Event only (ID=50004) I/O#1 averaging length (ID=50005)	S32

6.12.5 I/O#1 Event only (ID=50004)

Parameter defines whether element should be sent only when event is generated. Possible values:

- 1 – Yes (parameter ID and value is sent when event is generated);
- 0 – No (parameter ID and value is sent in every record).

Minimal value	Maximum value	Recommended value	Goes with (depends on) parameters	Value type
0	1	0	I/O#1 priority (ID=50000) I/O#1 logic operand (ID=50001) I/O#1 High level (ID=50002) I/O#1 Low level (ID=50003) I/O#1 Event only (ID=50004) I/O#1 averaging length (ID=50005)	S8

6.12.6 I/O#1 averaging length (ID=50005)

Parameter defines I/O property sample length to average. If no averaging needed default value is 1.

Minimum value	Maximum value	Recommended value	Goes with (depends on) parameters	Value type
0	2147483647	1	I/O#1 priority (ID=50000) I/O#1 logic operand (ID=50001) I/O#1 High level (ID=50002) I/O#1 Low level (ID=50003) I/O#1 Event only (ID=50004) I/O#1 averaging length (ID=50005)	S32

Other I/O property elements can be configured in same logic. All I/O element parameters are listed in the next table.

6.13 I\O elements parameters and types.

Parameter ID	Parameter Type	Default value	Value range		Parameter name
			Min	Max	
50000	Uint8	1	0	3	Ignition Priority
50001	Uint8	5	0	6	Ignition Operand
50002	Uint8	0	0	1	Ignition High level
50003	Uint8	0	0	1	Ignition Low level
50004	Uint8	0	0	1	Ignition Event only
50005	Uint16	10	0	65535	Ignition Average
7000	Uint8	0	0	10	Send SMS
8000	String	0	0	160	SMS Text
50010	Uint8	1	0	3	Movement Priority
50011	Uint8	5	0	6	Movement Operand
50012	Uint8	0	0	1	Movement High level
50013	Uint8	0	0	1	Movement Low level
50014	Uint8	0	0	1	Movement Event only
50015	Uint16	1	0	65535	Movement Average
7001	Uint8	0	0	10	Send SMS
8001	String	0	0	160	SMS Text
50020	Uint8	1	0	3	Data Mode Priority
50021	Uint8	5	0	6	Data Mode Operand
50022	Uint8	0	0	5	Data Mode High level
50023	Uint8	0	0	5	Data Mode Low level
50024	Uint8	0	0	1	Data Mode Event only
7002	Uint8	0	0	10	Send SMS
8002	String	0	0	160	SMS Text
50030	Uint8	1	0	3	GSM Signal Priority
50031	Uint8	5	0	6	GSM Signal Operand
50032	Uint8	0	0	5	GSM Signal High level
50033	Uint8	0	0	5	GSM Signal Low level
50034	Uint8	0	0	1	GSM Signal Event only
50035	Uint16	1	0	65535	GSM Signal Average
7003	Uint8	0	0	10	Send SMS
8003	String	0	0	160	SMS Text
50040	Uint8	1	0	3	Deep Sleep Priority
50041	Uint8	3	0	6	Deep Sleep Operand
50042	Uint8	0	0	2	Deep Sleep High level
50043	Uint8	0	0	2	Deep Sleep Low level
50044	Uint8	0	0	1	Deep Sleep Event only
7004	Uint8	0	0	10	Send SMS
8004	String	0	0	160	SMS Text
50050	Uint8	1	0	3	GNSS Status Priority
50051	Uint8	5	0	6	GNSS Status Operand
50052	Uint8	0	0	5	GNSS Status High level
50053	Uint8	0	0	5	GNSS Status Low level
50053	Uint8	0	0	1	GNSS Status Event only
7005	Uint8	0	0	10	Send SMS

8005	String	0	0	160	SMS Text
50060	Uint8	0	0	3	GNSS PDOP Priority
5006	Uint8	3	0	6	GNSS PDOP Operand
5006	Uint16	0	0	1000	GNSS PDOP High level
5006	Uint16	0	0	1000	GNSS PDOP Low level
5006	Uint8	0	0	1	GNSS PDOP Event only
5006	Uint16	10	0	65535	GNSS PDOP Average
7006	Uint8	0	0	10	Send SMS
8006	String	0	0	160	SMS Text
50070	Uint8	1	0	3	GNSS HDOP Priority
50071	Uint8	3	0	6	GNSS HDOP Operand
50072	Uint16	0	0	1000	GNSS HDOP High level
50073	Uint16	0	0	1000	GNSS HDOP Low level
50074	Uint8	0	0	1	GNSS HDOP Event only
50075	Uint16	10	0	65535	GNSS HDOP Average
7007	Uint8	0	0	10	Send SMS
8007	String	0	0	160	SMS Text
50080	Uint8	1	0	3	External Voltage Priority
50081	Uint8	6	0	6	External Voltage
50082	Uint16	1000	0	60000	External Voltage Hight
50083	Uint16	0	0	60000	External Voltage Low
50084	Uint8	0	0	1	External Voltage Event
50085	Uint16	10	0	65535	External Voltage Average
7008	Uint8	0	0	10	Send SMS
8008	String	0	0	160	SMS Text
50090	Uint8	1	0	3	Speed Priority
50091	Uint8	3	0	6	Speed Operand
50092	Uint16	0	0	300	Speed High level
50093	Uint16	0	0	300	Speed Low level
50094	Uint8	0	0	1	Speed Event only
50095	Uint16	1	0	65535	Speed Average
7009	Uint8	0	0	10	Send SMS
8009	String	0	0	160	SMS Text
50100	Uint8	0	0	3	GSM Cell ID Priority
50101	Uint8	3	0	6	GSM Cell ID Operand
50102	Uint32	0	0	999999	GSM Cell ID Hight level
50103	Uint32	0	0	999999	GSM Cell ID Low level
50104	Uint8	0	0	1	GSM Cell ID Event only
7010	Uint8	0	0	10	Send SMS
8010	String	0	0	160	SMS Text
50110	Uint8	0	0	3	GSM Area Code Priority
50111	Uint8	3	0	6	GSM Area Code Operand
50112	Uint32	0	0	999999	GSM Area Code Hight
50113	Uint32	0	0	999999	GSM Area Code Low
50114	Uint8	0	0	1	GSM Area Code Event
7011	Uint8	0	0	10	Send SMS

8011	String	0	0	160	SMS Text
50120	Uint8	1	0	3	Battery Voltage Priority
50121	Uint8	3	0	6	Battery Voltage Operand
50122	Uint16	0	0	5000	Battery Voltage High
50123	Uint16	0	0	5000	Battery Voltage Low
50124	Uint8	0	0	1	Battery Voltage Event
50125	Uint8	0	0	10	Battery Voltage Average
7012	Uint8	0	0	10	Send SMS
8012	String	0	0	160	SMS Text
50130	Uint8	1	0	3	Battery Current Priority
50131	Uint8	3	0	6	Battery Current Operand
50132	Uint16	0	0	5000	Battery Current High
50133	Uint16	0	0	5000	Battery Current Low
50134	Uint8	0	0	1	Battery Current Event
50135	Uint8	0	0	10	Battery Current Average
7013	Uint8	0	0	10	Send SMS
8013	String	0	0	160	SMS Text
50140	Uint8	0	0	3	Active GSM Operator Priority
50141	Uint8	5	0	6	Active GSM Operator
50142	Uint32	0	0	999999	Active GSM Operator
50143	Uint32	0	0	999999	Active GSM Operator
50144	Uint8	0	0	1	Active GSM Operator
7014	Uint8	0	0	10	Send SMS
8014	String	0	0	160	SMS Text
50150	Uint8	0	0	3	Trip Odometer Priority
50151	Uint8	3	0	6	Trip Odometer Operand
50152	Uint32	0	0	1000000	Trip Odometer High
50153	Uint32	0	0	1000000	Trip Odometer Low level
50154	Uint8	0	0	1	Trip Odometer Event
7015	Uint8	0	0	10	Send SMS
8015	String	0	0	160	SMS Text
50160	Uint8	0	0	3	Total Odometer Priority
50161	Uint8	3	0	6	Total Odometer
50162	Uint32	0	0	10000000	Total Odometer High
50163	Uint32	0	0	10000000	Total Odometer Low
50164	Uint8	0	0	1	Total Odometer Event
7016	Uint8	0	0	10	Send SMS
8016	String	0	0	160	SMS Text
50170	Uint8	0	0	3	Digital Input 1 Priority
50171	Uint8	0	0	6	Digital Input 1 Operand
50172	Uint8	0	0	1	Digital Input 1 High
50173	Uint8	0	0	1	Digital Input 1 Low level
50174	Uint8	0	0	1	Digital Input 1 Event only
50175	Uint16	1	0	65535	Digital Input 1 Average
7017	Uint8	0	0	10	Send SMS
8017	String	0	0	160	SMS Text
50180	Uint8	0	0	3	Analog Input 1 Priority

50181	Uint8	6	0	6	Analog Input 1 Operand
50182	Uint16	1000	0	30000	Analog Input 1 High
50183	Uint16	0	0	30000	Analog Input 1 Low level
50184	Uint8	0	0	1	Analog Input 1 Event
50185	Uint16	10	0	65535	Analog Input 1 Average
7018	Uint8	0	0	10	Send SMS
8018	String	0	0	160	SMS Text
50190	Uint8	0	0	3	Digital Output 1 Priority
50191	Uint8	0	0	6	Digital Output 1
50192	Uint8	0	0	1	Digital Output 1 High
50193	Uint8	0	0	1	Digital Output 1 Low
50194	Uint8	0	0	1	Digital Output 1 Event
50195	Uint16	1	0	65535	Digital Output 1 Average
7019	Uint8	0	0	10	Send SMS
8019	String	0	0	160	SMS Text
50200	Uint8	0	0	3	Fuel Used GPS Priority
50201	Uint8	3	0	6	Fuel Used GPS Operand
50202	Uint32	0	0	1000000	Fuel Used GPS High
50203	Uint32	0	0	1000000	Fuel Used GPS Low level
50204	Uint8	0	0	1	Fuel Used GPS Event
50205	Uint16	1	0	65535	Fuel Used GPS Average
7020	Uint8	0	0	10	Send SMS
8020	String	0	0	160	SMS Text
50210	Uint8	0	0	3	Fuel Rate GPS Priority
50211	Uint8	3	0	6	Fuel Rate GPS Operand
50212	Uint32	0	0	1000000	Fuel Rate GPS High level
50213	Uint32	0	0	1000000	Fuel Rate GPS Low level
50214	Uint8	0	0	1	Fuel Rate GPS Event only
50215	Uint16	1	0	65535	Fuel Rate GPS Average
7021	Uint8	0	0	10	Send SMS
8021	String	0	0	160	SMS Text
50220	Uint8	0	0	3	Axis X Priority
50221	Uint8	3	0	6	Axis X Operand
50222	Uint16	0	-8000	8000	Axis X High level
50223	Uint16	0	-8000	8000	Axis X Low level
50224	Uint8	0	0	1	Axis X Event only
50225	Uint16	1	0	65535	Axis X Average
7022	Uint8	0	0	10	Send SMS
8022	String	0	0	160	SMS Text
50230	Uint8	0	0	3	Axis Y Priority
50231	Uint8	3	0	6	Axis Y Operand
50232	Uint16	0	-8000	8000	Axis Y High level
50233	Uint16	0	-8000	8000	Axis Y Low level
50234	Uint8	0	0	1	Axis Y Event only
50235	Uint16	1	0	65535	Axis Y Average
7023	Uint8	0	0	10	Send SMS
8023	String	0	0	160	SMS Text

50240	Uint8	0	0	3	Axis Z Priority
50241	Uint8	3	0	6	Axis Z Operand
50242	Uint16	0	-8000	8000	Axis Z High level
50243	Uint16	0	-8000	8000	Axis Z Low level
50244	Uint8	0	0	1	Axis Z Event only
50245	Uint16	1	0	65535	Axis Z Average
7024	Uint8	0	0	10	Send SMS
8024	String	0	0	160	SMS Text

6.14 OBD elements parameters and types

Parameter ID	Parameter Type	Default value	Value range		Parameter name
			Min	Max	
40100	Uint8	0	0	3	Number Of DTC Priority
40101	Uint8	3	0	6	Number Of DTC Operand
40102	Uint8	0	0	255	Number Of DTC High level
40103	Uint8	0	0	255	Number Of DTC Low level
40104	Uint8	0	0	1	Number Of DTC Event only
7038	Uint8	0	0	10	Number Of DTC Send SMS
8038	String	0	0	160	Number Of DTC SMS Text
40110	Uint8	0	0	3	Engine Load Priority
40111	Uint8	3	0	6	Engine Load Operand
40112	Uint8	0	0	100	Engine Load High level
40113	Uint8	0	0	100	Engine Load Low level
40114	Uint8	0	0	1	Engine Load Event only
7039	Uint8	0	0	10	Engine Load Send SMS
8039	String	0	0	160	Engine Load SMS Text
40120	Uint8	0	0	3	Coolant Temperature Priority
40121	Uint8	3	0	6	Coolant Temperature Operand
40122	Int8	0	-40	215	Coolant Temperature e High level
40123	Int8	0	-40	215	Coolant Temperature Low level
40124	Uint8	0	0	1	Coolant Temperature Event only
7040	Uint8	0	0	10	Coolant Temperature Send SMS
8040	String	0	0	160	Coolant Temperature SMS Text
40130	Uint8	0	0	3	Short Fuel Trim Priority
40131	Uint8	3	0	6	Short Fuel Trim Operand
40132	Uint8	0	0	255	Short Fuel Trim High level
40133	Uint8	0	0	255	Short Fuel Trim Low level
401034	Uint8	0	0	1	Short Fuel Trim Event only
7003	Uint8	0	0	10	Short Fuel Trim Send SMS
8003	String	0	0	160	Short Fuel Trim SMS Text
40140	Uint8	0	0	3	Fuel Pressure Priority
40141	Uint8	3	0	6	Fuel Pressure Operand
40142	Uint16	0	0	765	Fuel Pressure High level
40143	Uint16	0	0	765	Fuel Pressure Low level
40144	Uint8	1	0	1	Fuel Pressure Event only
7042	Uint8	0	0	10	Fuel Pressure Send SMS

8042	String	0	0	160	Fuel Pressure SMS Text
40150	Uint8	0	0	3	Intake Map Priority
40151	Uint8	3	0	6	Intake Map Operand
40152	Uint8	0	0	255	Intake Map High level
40153	Uint8	0	0	255	Intake Map Low level
40153	Uint8	1	0	1	Intake Map Event only
7043	Uint8	0	0	10	Intake Map Send SMS
8043	String	0	0	160	Intake Map SMS Text
40160	Uint8	0	0	3	Engine RPM Priority
40161	Uint8	3	0	6	Engine RPM Operand
40162	Uint16	0	0	16384	Engine RPM High level
40163	Uint16	0	0	16384	Engine RPM Low level
40164	Uint8	0	0	1	Engine RPM Event only
7044	Uint8	0	0	10	Engine RPM Send SMS
8044	String	0	0	160	Engine RPM SMS Text
40170	Uint8	0	0	3	Vehicle speed Priority
40171	Uint8	3	0	6	Vehicle speed Operand
40172	Uint8	0	0	255	Vehicle speed High level
40173	Uint8	0	0	255	Vehicle speed Low level
40174	Uint8	0	0	1	Vehicle speed Event only
7045	Uint8	0	0	10	Vehicle speed Send SMS
8045	String	0	0	160	Vehicle speed SMS Text
40180	Uint8	0	0	3	Timing advance Priority
40181	Uint8	3	0	6	Timing advance Operand
40182	Int8	0	-64	64	Timing advance High level
40183	Int8	0	-64	64	Timing advance Low level
40184	Uint8	0	0	1	Timing advance Event only
7046	Uint8	0	0	10	Timing advance Send SMS
8046	String	0	0	160	Timing advance SMS Text
40190	Uint8	0	0	3	Intake air temperature Priority
40191	Uint8	3	0	6	Intake air temperature Operand
40192	Int8	0	-40	215	Intake air temperature High level
40193	Int8	0	-40	215	Intake air temperature Low level
40194	Uint8	1	0	1	Intake air temperature Event only
7047	Uint8	0	0	10	Intake air temperature Send SMS
8047	String	0	0	160	Intake air temperature SMS Text
40200	Uint8	0	0	3	MAF Priority
40201	Uint8	3	0	6	MAF Operand
40202	Uint16	0	0	656	MAF High level
40203	Uint16	0	0	656	MAF Low level
40204	Uint8	0	0	1	MAF Event only
7048	Uint8	0	0	10	MAF Send SMS
8048	String	0	0	160	MAF SMS Text
40210	Uint8	0	0	3	Throttle position Priority
40211	Uint8	3	0	6	Throttle position Operand
40212	Uint8	0	0	100	Throttle position High level
40213	Uint8	0	0	100	Throttle position Low level
40214	Uint8	0	0	1	Throttle position Event only

7049	Uint8	0	0	10	Throttle position Send SMS
8049	String	0	0	160	Throttle position SMS Text
40220	Uint8	0	0	3	Run time since engine start Priority
40221	Uint8	3	0	6	Run time since engine start Operand
40222	Uint16	0	0	65535	Run time since engine start High level
40223	Uint16	0	0	65535	Run time since engine start Low level
40224	Uint8	0	0	1	Run time since engine start Event only
7050	Uint8	0	0	10	Run time since engine start Send SMS
8050	String	0	0	160	Run time since engine start SMS Text
40230	Uint8	0	0	3	Distance traveled MIL on Priority
40231	Uint8	3	0	6	Distance traveled MIL on Operand
40232	Uint16	0	0	65535	Distance traveled MIL on High level
40233	Uint16	0	0	65535	Distance traveled MIL on Low level
40234	Uint8	0	0	1	Distance traveled MIL on Event only
7051	Uint8	0	0	10	Distance traveled MIL on Send SMS
8051	String	0	0	160	Distance traveled MIL on SMS Text
40240	Uint8	0	0	3	Relative fuel rail pressure Priority
40241	Uint8	5	0	6	Relative fuel rail pressure Operand
40242	Uint16	0	0	5178	Relative fuel rail pressure High level
40243	Uint16	0	0	5178	Relative fuel rail pressure Low level
40244	Uint8	0	0	1	Relative fuel rail pressure Event only
7052	Uint8	0	0	10	Relative fuel rail pressure Send SMS
8052	String	0	0	160	Relative fuel rail pressure SMS Text
40250	Uint8	0	0	3	Direct fuel rail pressure Priority
40251	Uint8	3	0	6	Direct fuel rail pressure Operand
40252	Uint16	0	0	656	Direct fuel rail pressure High level
40253	Uint16	0	0	656	Direct fuel rail pressure Low level
40254	Uint8	0	0	1	Direct fuel rail pressure Event only
7053	Uint8	0	0	10	Direct fuel rail pressure Send SMS
8053	String	0	0	160	Direct fuel rail pressure SMS Text
40260	Uint8	0	0	3	Commanded EGR Priority
40261	Uint8	3	0	6	Commanded EGR Operand
40262	Uint8	0	0	100	Commanded EGR High level
40263	Uint8	0	0	100	Commanded EGR Low level
40264	Uint8	0	0	1	Commanded EGR Event only
7054	Uint8	0	0	10	Commanded EGR Send SMS
8054	String	0	0	160	Commanded EGR SMS Text
40270	Uint8	0	0	3	EGR error Priority
40271	Uint8	3	0	6	EGR error Operand
40272	Int8	0	-100	100	EGR error High level
40273	Int8	0	-100	100	EGR error Low level
40274	Uint8	0	0	1	EGR error Event only
7055	Uint8	0	0	10	EGR error Send SMS
8055	String	0	0	160	EGR error SMS Text
40280	Uint8	0	0	3	Fuel level Priority
40281	Uint8	3	0	6	Fuel level Operand
40282	Uint8	0	0	100	Fuel level High level
40283	Uint8	0	0	100	Fuel level Low level

40284	Uint8	0	0	1	Fuel level Event only
7056	Uint8	0	0	10	Fuel level Send SMS
8056	String	0	0	160	Fuel level SMS Text
40290	Uint8	0	0	3	Distance traveled since codes clear Priority
40291	Uint8	3	0	6	Distance traveled since codes clear Operand
40292	Uint16	0	0	65535	Distance traveled since codes clear High level
40293	Uint16	0	0	65535	Distance traveled since codes clear Low level
40294	Uint8	0	0	1	Distance traveled since codes clear Event only
7057	Uint8	0	0	10	Distance traveled since codes clear Send SMS
8057	String	0	0	160	Distance traveled since codes clear SMS Text
40300	Uint8	0	0	3	Barometric pressure Priority
40301	Uint8	3	0	6	Barometric pressure Operand
40302	Uint8	0	0	255	Barometric pressure High level
40303	Uint8	0	0	255	Barometric pressure Low level
40304	Uint8	0	0	1	Barometric pressure Event only
7058	Uint8	0	0	10	Barometric pressure Send SMS
8058	String	0	0	160	Barometric pressure SMS Text
40310	Uint8	0	0	3	Control module voltage Priority
40311	Uint8	3	0	6	Control module voltage Operand
40312	Uint16	0	0	65535	Control module voltage High level
40313	Uint16	0	0	65535	Control module voltage Low level
40314	Uint8	0	0	1	Control module voltage Event only
7059	Uint8	0	0	10	Control module voltage Send SMS
8059	String	0	0	160	Control module voltage SMS Text
40320	Uint8	0	0	3	Absolute load value Priority
40321	Uint8	3	0	6	Absolute load value Operand
40322	Uint16	0	0	25700	Absolute load value High level
40323	Uint16	0	0	25700	Absolute load value Low level
40324	Uint8	0	0	1	Absolute load value Event only
7060	Uint8	0	0	10	Absolute load value Send SMS
8060	String	0	0	160	Absolute load value SMS Text
40330	Uint8	0	0	3	Ambient air temperature Priority
40331	Uint8	3	0	6	Ambient air temperature Operand
40332	Int8	0	-40	215	Ambient air temperature High level
40333	Int8	0	-40	215	Ambient air temperature Low level
40334	Uint8	0	0	1	Ambient air temperature Event only
7061	Uint8	0	0	10	Ambient air temperature Send SMS
8061	String	0	0	160	Ambient air temperature SMS Text
40340	Uint8	0	0	3	Time run with MIL on Priority
40341	Uint8	3	0	6	Time run with MIL on Operand
40342	Uint16	0	0	65535	Time run with MIL on High level
40343	Uint16	0	0	65535	Time run with MIL on Low level
40344	Uint8	0	0	1	Time run with MIL on Event only
7062	Uint8	0	0	10	Time run with MIL on Send SMS
8062	String	0	0	160	Time run with MIL on SMS Text
40350	Uint8	0	0	3	Time since trouble codes cleared Priority
40351	Uint8	3	0	6	Time since trouble codes cleared Operand

40352	Uint16	0	0	65535	Time since trouble codes cleared Hight level
40353	Uint16	0	0	65535	Time since trouble codes cleared Low level
40354	Uint8	0	0	1	Time since trouble codes cleared Event only
7063	Uint8	0	0	10	Time since trouble codes cleared Send SMS
8063	String	0	0	160	Time since trouble codes cleared SMS Text
40360	Uint8	0	0	3	Absolute fuel rail pressure Priority
40361	Uint8	3	0	6	Absolute fuel rail pressure Operand
40362	Uint16	0	0	65535	Absolute fuel rail pressure Hight level
40363	Uint16	0	0	65535	Absolute fuel rail pressure Low level
40364	Uint8	0	0	1	Absolute fuel rail pressure Event only
7064	Uint8	0	0	10	Absolute fuel rail pressure Send SMS
8064	String	0	0	160	Absolute fuel rail pressure SMS Text
40370	Uint8	0	0	3	Hybrid battery pack remaining life Priority
40371	Uint8	3	0	6	Hybrid battery pack remaining life Operand
40372	Uint8	0	0	100	Hybrid battery pack remaining life Hight level
40373	Uint8	0	0	100	Hybrid battery pack remaining life Low level
40374	Uint8	0	0	1	Hybrid battery pack remaining life Event only
7065	Uint8	0	0	10	Hybrid battery pack remaining life Send SMS
8065	String	0	0	160	Hybrid battery pack remaining life SMS Text
40380	Uint8	0	0	3	Engine oil temperature Priority
40381	Uint8	3	0	6	Engine oil temperature Operand
40382	Int8	0	-40	210	Engine oil temperature Hight level
40383	Int8	0	-40	210	Engine oil temperature Low level
40384	Uint8	0	0	1	Engine oil temperature Event only
7066	Uint8	0	0	10	Engine oil temperature Send SMS
8066	String	0	0	160	Engine oil temperature SMS Text
40390	Uint8	0	0	3	Fuel injection timing Priority
40391	Uint8	3	0	6	Fuel injection timing Operand
40392	Int16	0	-21000	30200	Fuel injection timing Hight level
40393	Int16	0	-21000	30200	Fuel injection timing Low level
40394	Uint8	0	0	1	Fuel injection timing Event only
7067	Uint8	0	0	10	Fuel injection timing Send SMS
8067	String	0	0	160	Fuel injection timing SMS Text
40400	Uint8	0	0	3	Fuel Rate Priority
40401	Uint8	3	0	6	Fuel Rate Operand
40402	Uint16	0	0	32767	Fuel Rate Hight level
40403	Uint16	0	0	32767	Fuel Rate Low level
40404	Uint8	0	0	1	Fuel Rate Event only
7068	Uint8	0	0	10	Fuel Rate Send SMS
8068	String	0	0	160	Fuel Rate SMS Text

CHANGE LOG

Nr.	Date	Version	Comments
1	2017-01-11	0.01	Preliminary draft release.
2	2017-01-24	0.02	Bluetooth radio, accelerometer scenarios, time synchronization explanation added, parameter IDs for remote configuration added.
3	2017-02-07	0.03	I/O element parameter IDs updated.
4	2017-02-21	0.04	Updated IO element "Event only" parameter values
5	2017-04-05	0.05	Updated I\O elements, sms ID parameter description.
6	2017-04-13	0.06	Added "Supported OBD protocols".
7	2017-05-08	0.07	Sim insert edited. Added sms commands. Bluetooth: debug over android, OBD dongle connection, hands free connection. Crash Trase.
8	2017-05-16	0.08	Deep Sleep Current edited
9	2017-06-02	0.09	Micro Sim image edited
10	2017-06-07	0.10	Updated devices image
11	2017-07-21	0.11	Updated SMS ID, SMS command, setparam description.
12	2017-09-13	0.12	Removed Spy Call, updated OBD parameters